

POSI-SEAL[®] Type A31A Cryogenic High Performance Butterfly Valve

Description

The Type A31A Cryogenic High Performance Butterfly Valve (HPBV) is designed for extreme temperature cryogenic services and features a valve body extension which positions the packing system and the actuator away from the extreme temperatures. The 3- through 12-inch sizes feature a unique one-piece investment cast extension housing (see figures 1 and 2). The 14- through 24-inch sizes employ a two-piece fabricated extension housing. The valve also features a metal NOVEX[™] seal as standard providing tight shutoff, low operating torques and the rugged durability needed for cryogenic service.

The Type A31A Cryogenic HPBV has been developed as a valve/actuator package with a Double D drive shaft (standard for sizes 3- through 12-inch) to allow easy, direct mounting to the Type 1035 Rack and Pinion actuator, eliminating the need

for external coupling systems. Also available are keyed shaft (standard for sizes 14- through 24-inch) and splined drive shafts to allow easy mounting to other Fisher actuators.

The A31A Cryogenic HPBV is available in either flangeless (wafer) or single flange styles, and S31600 (316 SST) is the standard valve body and disc material. This valve is offered in full rated 150 and 300 pressure classes.

Note

Fisher does not assume responsibility for the selection, use, or maintenance of any product. Responsibility for proper selection, use, and maintenance of any Fisher product remains solely with the purchaser and end-user.



W7451 / IL

Figure 1. Type A31A Cryogenic Valve with Type 1035 Actuator



Specifications

Valve Body Sizes and Ratings

- 3, ■ 4, ■ 6, ■ 8, ■ 10, and ■ 12-inch Classes 150 and 300
- 14 through 24-inch sizes are also available in Classes 150 and 300.

End Connection Style

- Flangeless, wafer-style or ■ single flange valve body designed to fit between raised-face mating flanges per ASME B16.5 Class 150 or 300

Maximum Inlet Pressure/Temperature⁽¹⁾

Consistent with Class ■ 150 and ■ 300 pressure/temperature ratings per ASME B16.34, except that 38°C (100°F) rating is applicable to -254°C (-425°F). NOVEX seal maximum pressure/temperature rating is the same as the valve body. See figure 4 for rating of Kel-F seal.

Temperature Range⁽¹⁾

-234 to 260°C (-425 to 500°F)

Available Seal Configurations

See figure 3 and table 2

Standard Construction Materials

- Valve Body and Disc:** ASTM grades of S31600 stainless steel
- Disc Coating:** Hardcoating Standard (Chrome or Nickel)
- Shaft:** ■ ASTM grade of S17400 (17-4PH H1150M SST); ■ N05500 (K-Monel, Optional), ■ N07718 (Inconel, Optional)
- Seal Ring:** ■ S31600 (316 SST) NOVEX Std for CL 150, ■ S21800 (Nitronic 60) NOVEX Std for CL 300, ■ Kel-F⁽²⁾ optional, or ■ Kel-F⁽²⁾ with Aluminum Back-up ring optional
- Packing:** ■ PTFE V-ring, or ■ graphite (optional)

Bearings: ■ PTFE Composition, or ■ bronze (optional)

Valve Body Classification

Face-to-face dimensions are in compliance with MSS SP68 and API 609 standards; valve bodies are designed for installation between ASME B16.5 Class 150 or 300 raised-face flanges

Shutoff Classification.

Unidirectional Reverse flow. Per ANSI/FCI 70-2 and IEC 60534-4 at ambient temperature

NOVEX Seal: Class VI

KEL-F Seal: 0.1% of Class IV

KEL-F Seal with Aluminum back-up ring: Class VI

Flow Characteristic

Modified equal percentage

Flow Coefficients

See the section titled Coefficients in this bulletin

Noise Levels

See Catalog 12 for sound pressure level prediction

Available Actuators

- Rack and Pinion Type 1035 for sizes 3 through 12-inch, ■ Bettis G Series for keyed shaft sizes 14 through 24-inch or ■ Rotary Diaphragm Types 1051 and 1052 for splined shafts

Disc Rotation

Clockwise to close

Valve Dimensions and Approximate Weights

See figures 6, 7, 8, 9, 10, 11, 12, and 13 and tables 1, 3, 4, 5, 6, 7, 8, 9 and 10.

1. The pressure/temperature limits in this bulletin, and any application code or standard limitation, should not be exceeded.
2. Kel-F not recommended for fast cycling, less than 2 seconds.

W7449 / IL



Figure 2. Type A31A Cryogenic Valve, Single Flange Style

Table 1. Approximate Weights

VALVE SIZE	WAFER CLASS 150		SINGLE FLANGE CLASS 150		WAFER CLASS 300		SINGLE FLANGE CLASS 300	
	kg	lbs	kg	lbs	kg	lbs	kg	lbs
3	12	27	16	36	12	27	16	35
4	21	46	22	48	21	46	24	52
6	24	53	28	61	24	53	28	61
8	34	75	40	89	47	104	52	115
10	57	125	67	148	80	176	100	220
12	74	164	93	206	103	227	135	298
14	87	191	120	265	142	314	249	548
16	133	294	182	401	213	470	325	716
18	170	374	231	510	259	570	434	956
20	210	463	302	665	401	884	582	1282
24	326	719	455	1004	512	1128	863	1903

Features

- **Cryogenic Seal Improvement**— The NOVEX pressure-assisted metal seal design provides tight shutoff (ANSI Class VI, ambient) and permits the use of smaller, less expensive actuators in applications requiring full ASME B16.34 shutoff capabilities. The NOVEX seal is standard on all Type A31A Cryogenic valves.

- **Direct Actuation**—The Type A31A Cryogenic 3 through 8-inch Double D shaft allows direct mounting with the Type 1035 actuator, eliminating the need for a coupler.

- **Excellent Shutoff Integrity**—Concentric rotation enables the valve disc to remain in the closed position in spite of line pressure surges or actuator failure.

- **Safety**—Redundant shaft retention provides added protection. The packing follower and shaft step interact to hold the shaft securely in the valve body. The 3 through 12-inch sizes use a one-piece packing follower, and the 14- through 24-inch sizes use a two-piece follower (see figure 5).

- **Strength**— The cast S31600 one-piece extensions are welded directly onto the 3 through 8-inch size valves for greater strength under service conditions.

- **Easy Installation**—The valve body self-centers on the line flange bolts as a fast, accurate means of centering the valve in the pipeline.

- **Reliable Flange Gasketing Surface**—Seal retainer screws are located so there is no interference with the sealing function of either flat sheet or spiral wound line flange gaskets.

Installation

Recommended installation for the Type A31A Cryogenic valve is with the shaft upstream of the seal (reverse flow).

Dimensions for wafer-style and single-flange valves are shown in figures 6, 7, 8, 9, 10, 11, 12, and 13 and tables 3, 4, 5, 6, 7, 8, 9 and 10.

For assistance in selecting the appropriate combination of actuator action and open valve position, consult your Fisher sales office.

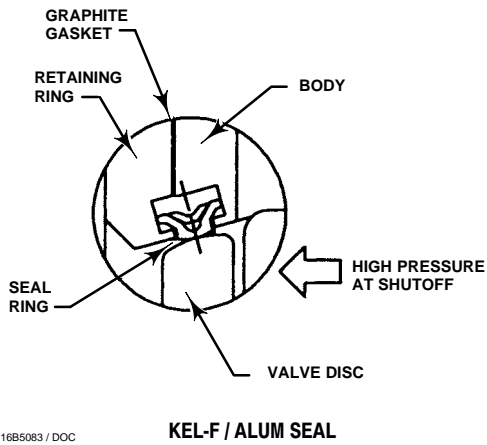
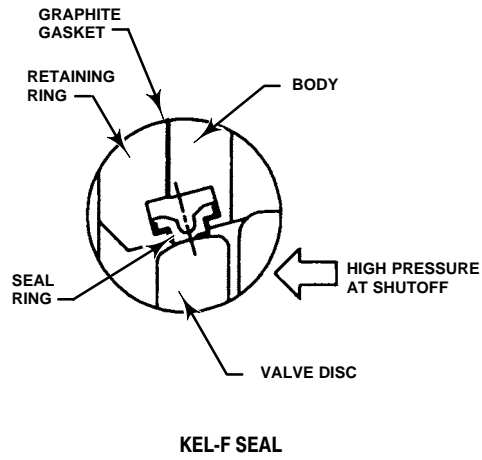
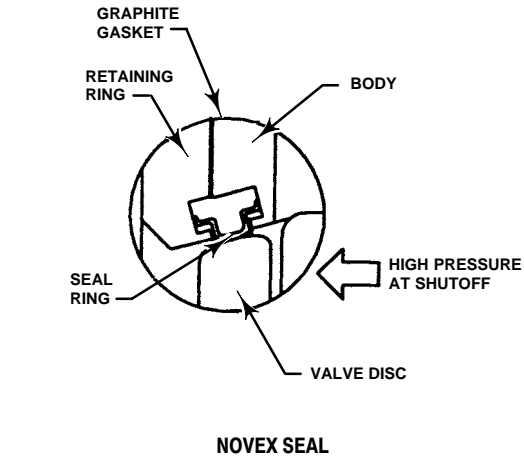

16B5083 / DOC

Figure 3. Available Seal Configurations

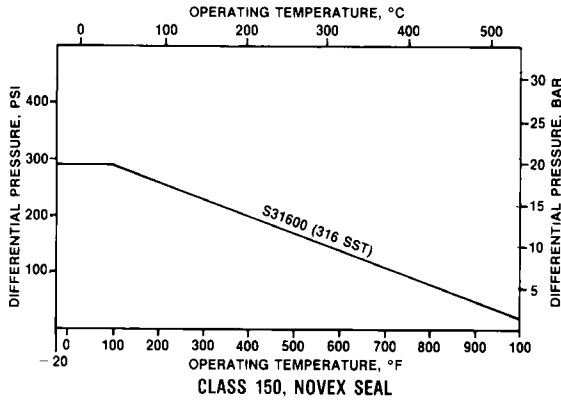

C0759-1 / IL

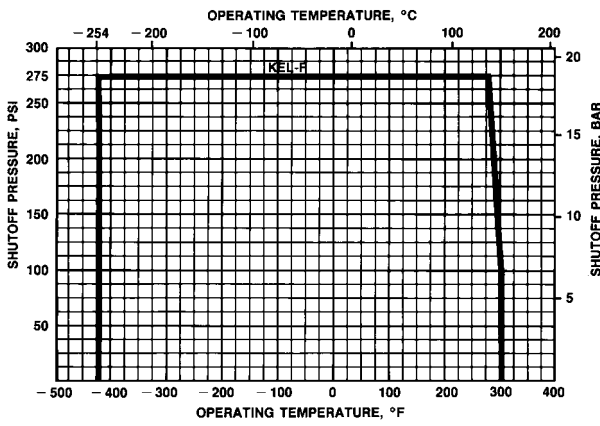
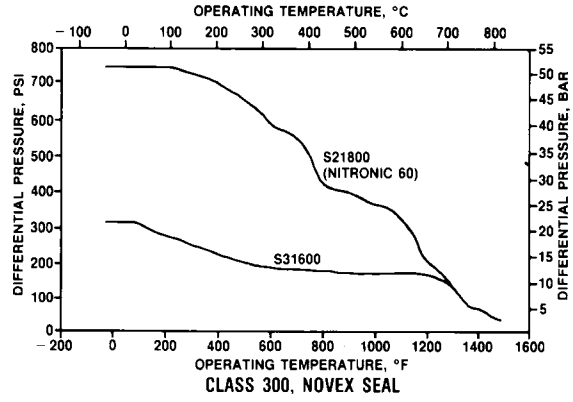

A4132-1 / IL

CLASS 150, KEL-F SEAL

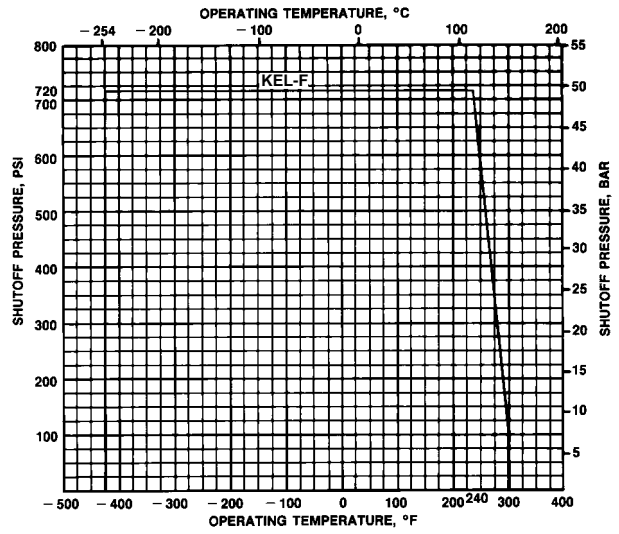

A3715-2 / IL

CLASS 300, KEL-F SEAL

Figure 4. Maximum Pressure/Temperature Ratings

A31A Cryogenic Valve

Table 2. Material Temperature Ratings

COMPONENT AND MATERIAL OF CONSTRUCTION		TEMPERATURE RANGE	
		°C	°F
Valve Body CF8M (316 SST) Class 150 and 300		-254 to 260	-425 to 500
Disc CF8M (316 SST)		-254 to 260	-425 to 500
Disc Coating Hard Coating ⁽¹⁾		-254 to 260	-425 to 500
Shaft S17400 (17-4 pH H1150M) (standard) K-Monel (N05500) Inconel (N07718)		-196 to 260 -198 to 260 -254 to 260	-320 to 500 -325 to 500 -425 to 500
Bearings PTFE Composition Rexnord (standard) Bronze		-254 to 163 -254 to 260	-425 to 325 -425 to 500
Packing PTFE Packing (standard) Graphite		-254 to 232 -254 to 260	-425 to 450 -425 to 500
Seal Ring	NOVEX S31600 Seal Ring (Class 150) (standard)	-254 to 260	-425 to 500
	NOVEX S21800 Seal Ring (Class 300) (standard)	-254 to 260	-425 to 500
	Kel-F Cryogenic Seal Ring	-254 to 149	-425 to 300

1. The material for hard coating on the disc is either hard chrome plating or Electroless Nickel Coating (ENC) depending upon availability.

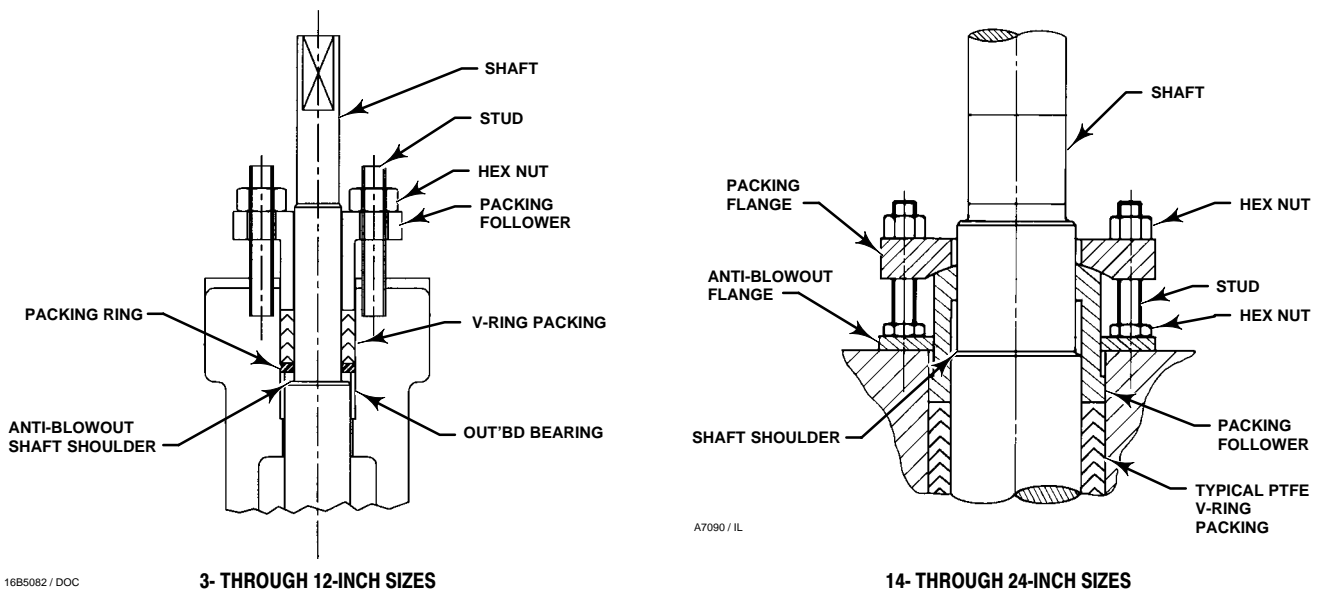
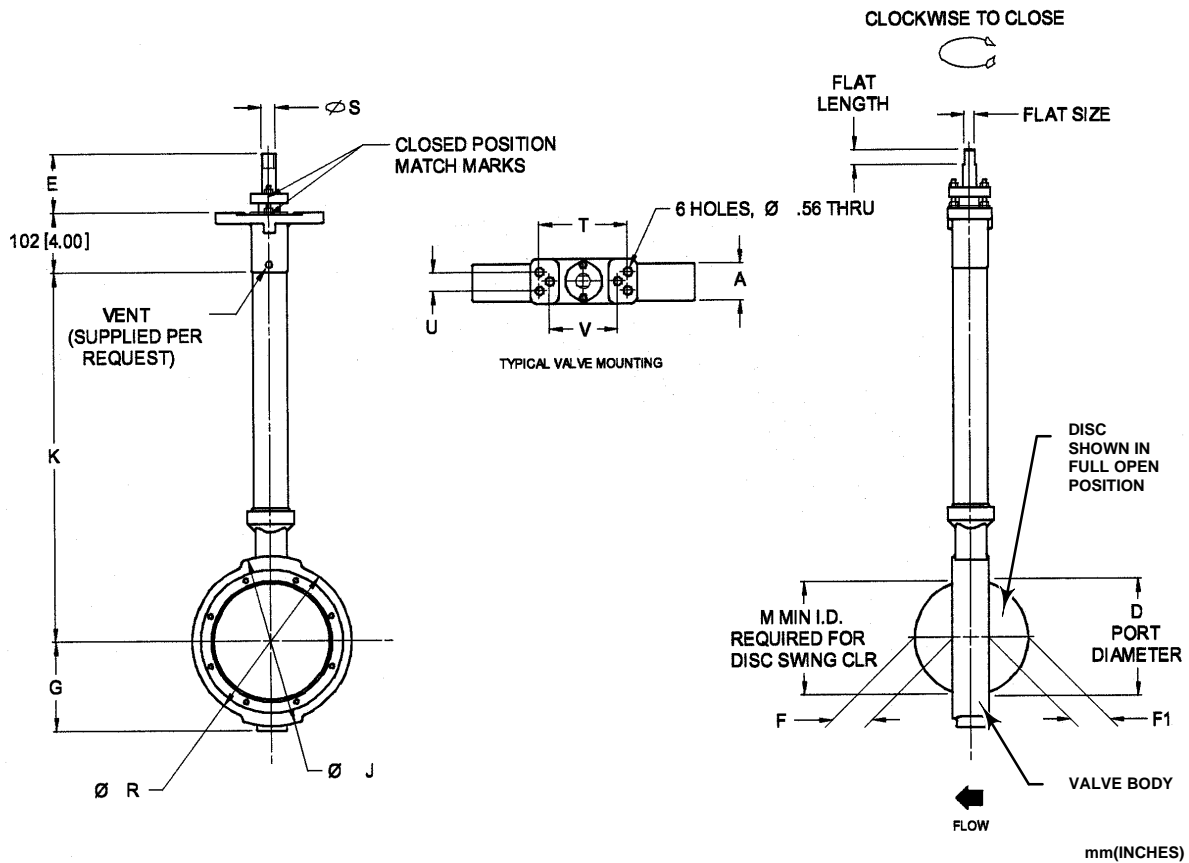

Figure 5. Anti-Blowout Protection

Table 3. Dimensions, Wafer Style Valves, ANSI Class 150, Sizes 3 through 8-Inch

VALVE SIZE, INCH	A	D	E	F	F1	G	J	K	M ⁽²⁾	R ⁽¹⁾	S	T	U	V	FLAT LENGTH	FLAT SIZE
mm																
3	48	87	83	10	19	79	146	375	71	133	16	152	32	117	25	11
4	54	113	83	22	25	95	178	451	94	171	19	152	32	117	25	14
6	57	165	83	41	51	127	248	489	148	219	25	152	32	117	25	17
8	64	210	83	65	68	152	---	679	197	273	25	152	32	117	25	17
Inches																
3	1.88	3.44	3.25	0.38	0.75	3.13	5.75	14.75	2.82	5.25	0.625	6.0	1.25	4.63	1.0	0.436
4	2.13	4.44	3.25	0.88	1.0	3.75	7.0	17.75	3.69	6.75	0.75	6.0	1.25	4.63	1.0	0.561
6	2.25	6.50	3.25	1.63	2.0	5.0	9.75	19.25	5.82	8.63	1	6.0	1.25	4.63	1.0	0.687
8	2.50	8.25	3.25	2.57	2.69	6.0	---	26.75	7.75	10.75	1	6.0	1.25	4.63	1.0	0.687

1. Face-to-face dimensions are in compliance with MSS SP68 and API 609 specifications.
 2. Minimum I.D. is the minimum pipe or flange I.D. required for disc swing clearance.



16B4210 / DOC

Figure 6. Dimensions, Wafer Style Valves, ANSI Class 150, Sizes 3- through 8-Inch (also see table 3)

A31A Cryogenic Valve

Table 4. Dimensions, Single Flange Style Valves, ANSI Class 150, Sizes 3 through 8-Inch

VALVE SIZE, INCH	A	D	E	F	F1	J	K	M ⁽²⁾	R ⁽¹⁾	S	T	U	V	W	FLAT LENGTH	FLAT SIZE
mm																
3	48	87	83	10	19	152	375	71	207	16	152	32	117	See thread information below	25	11
4	54	113	83	22	25	191	451	94	238	19	152	32	117		25	14
6	57	165	83	41	51	241	489	148	308	25	152	32	117		25	17
8	64	210	83	65	68	298	679	197	336	25	152	32	117		25	17
Inches																
3	1.88	3.44	3.25	0.375	0.75	6.0	14.75	2.82	8.25	0.625	6.0	1.25	4.63	0.625-11 4 holes	1.0	0.436
4	2.13	4.44	3.25	0.875	1.0	7.5	17.75	3.69	9.38	0.75	6.0	1.25	4.63	0.625-11 8 holes	1.0	0.561
6	2.25	6.50	3.25	1.63	2.0	9.5	19.25	5.82	12.13	1	6.0	1.25	4.63	0.75-10 8 holes	1.0	0.687
8	2.50	8.25	3.25	2.57	2.69	11.75	26.75	7.75	13.25	1	6.0	1.25	4.63	0.75-10 8 holes	1.0	0.687

1. Face-to-face dimensions are in compliance with MSS SP68 and API 609 specifications.
2. Minimum I.D. is the minimum pipe or flange I.D. required for disc swing clearance.

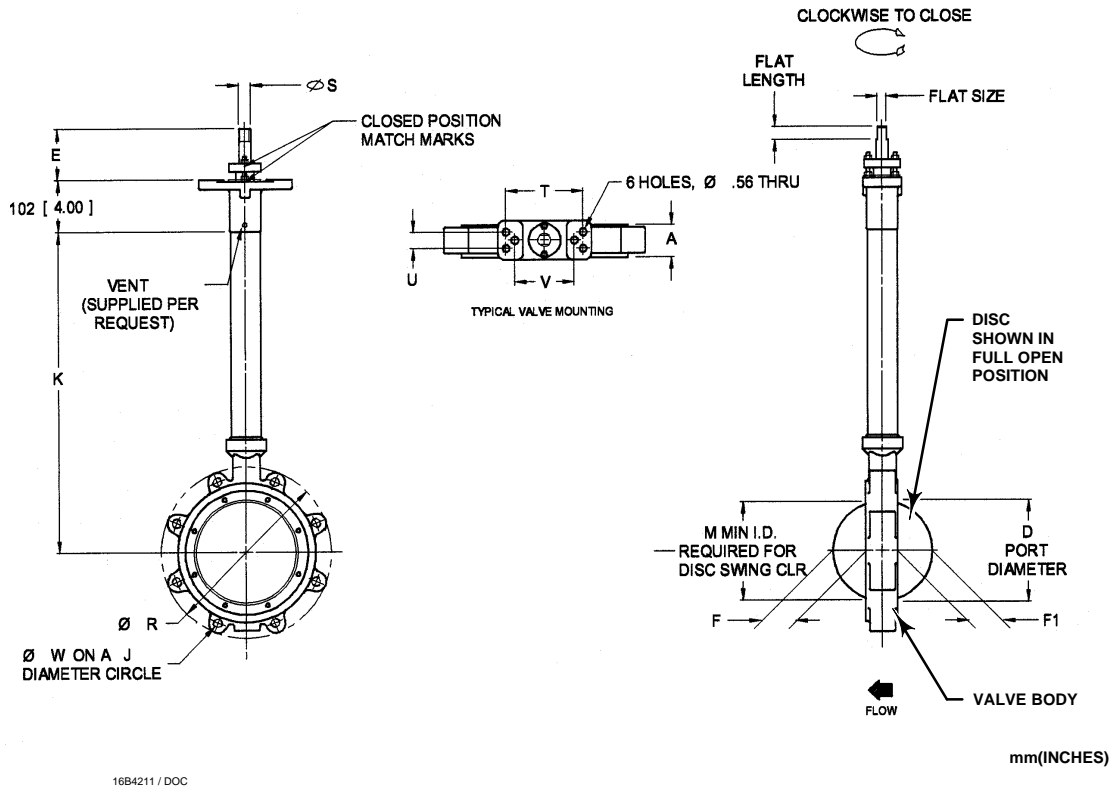
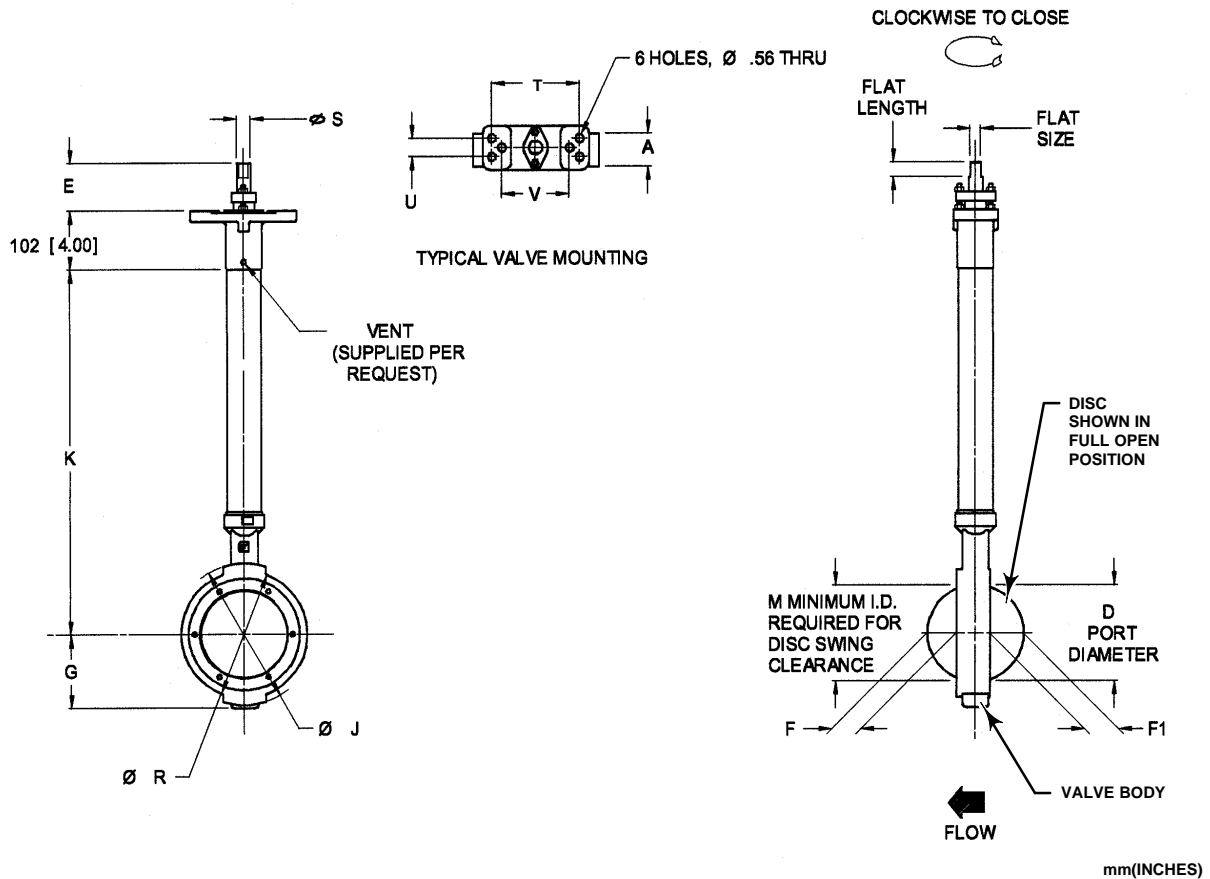

Figure 7. Dimensions, Single Flange Style Valves, ANSI Class 150, Sizes 3- through 8-Inch (also see table 4)

Table 5. Dimensions, Wafer Style valves, ANSI Class 300, Sizes 3 through 6-Inch

VALVE SIZE, INCH	A	D	E	F	F1	G	J	K	M ⁽²⁾	R ⁽¹⁾	S	T	U	V	FLAT LENGTH	FLAT SIZE
mm																
3	48	87	83	10	19	79	146	375	71	133	16	152	32	117	25	11
4	54	113	83	22	25	95	178	451	94	171	19	152	32	117	25	14
6	57	164	83	41	48	127	248	489	146	219	25	152	32	117	25	17
Inches																
3	1.88	3.44	3.25	0.375	0.75	3.13	5.75	14.75	2.81	5.25	0.625	6.0	1.25	4.63	1.0	0.436
4	2.13	4.44	3.25	0.875	1.0	3.75	7.0	17.75	3.69	6.75	0.75	6.0	1.25	4.63	1.0	0.561
6	2.25	6.44	3.25	1.63	1.88	5.0	9.75	19.25	5.75	8.63	1	6.0	1.25	4.63	1.0	0.687

1. Face-to-face dimensions are in compliance with MSS SP68 and API 609 specifications.
 2. Minimum I.D. is the minimum pipe or flange I.D. required for disc swing clearance.



16B4212 / DOC

Figure 8. Dimensions, Wafer Style valves, ANSI Class 300, Sizes 3 through 6-Inch (also see table 5)

A31A Cryogenic Valve

Table 6. Dimensions, Single Flange Style Valves, ANSI Class 300, Sizes 3 through 6-Inch

VALVE SIZE, INCH	A	D	E	F	F1	J	K	M ⁽²⁾	R ⁽¹⁾	S	T	U	V	W	FLAT LENGTH	FLAT SIZE
mm																
3	48	87	83	10	19	168	375	71	207	16	152	32	117	See thread information below	25	11
4	54	113	83	22	25	200	451	94	238	19	152	32	117		25	14
6	57	164	83	41	48	270	489	146	308	25	152	32	117		25	17
Inches																
3	1.88	3.44	3.25	0.375	0.75	6.63	14.75	2.81	8.13	0.625	6.0	1.25	4.63	0.75-10 8 holes	1.0	0.436
4	2.13	4.44	3.25	0.875	1.0	7.88	17.75	3.69	9.75	0.75	6.0	1.25	4.63	0.75-10 8 holes	1.0	0.561
6	2.25	6.44	3.25	1.63	1.88	10.63	19.25	5.75	12.63	1	6.0	1.25	4.63	0.75-10 12 holes	1.0	0.687

1. Face-to-face dimensions are in compliance with MSS SP68 and API 609 specifications.
2. Minimum I.D. is the minimum pipe or flange I.D. required for disc swing clearance.

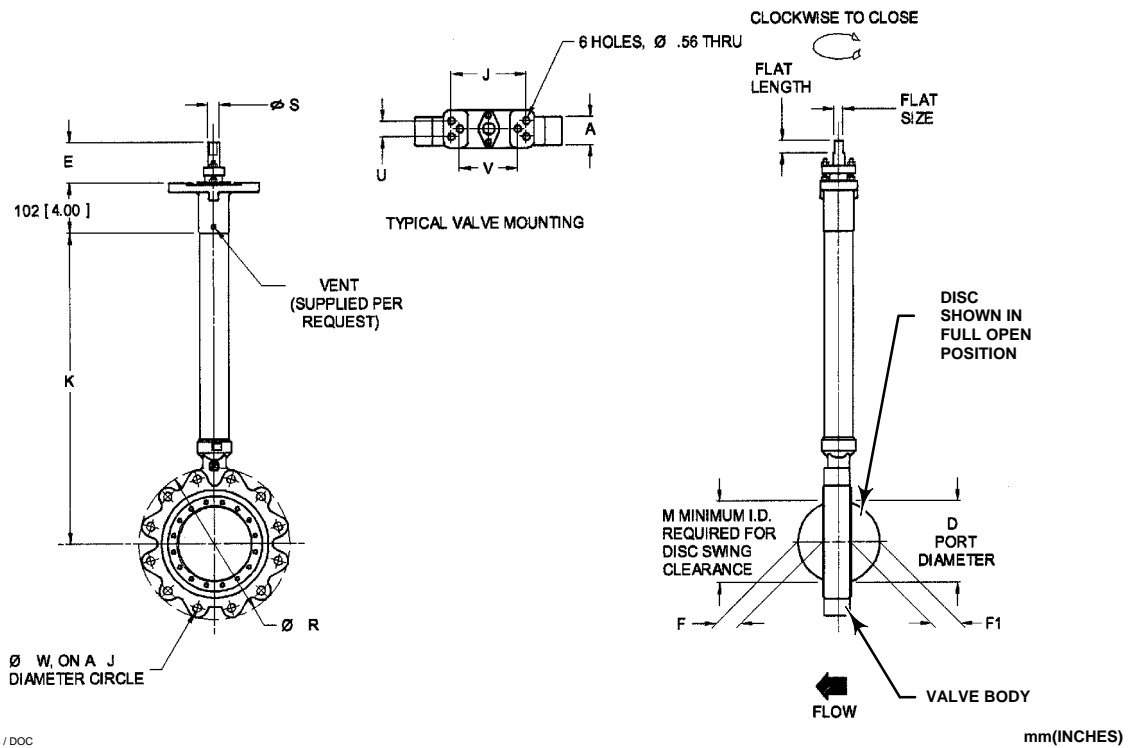
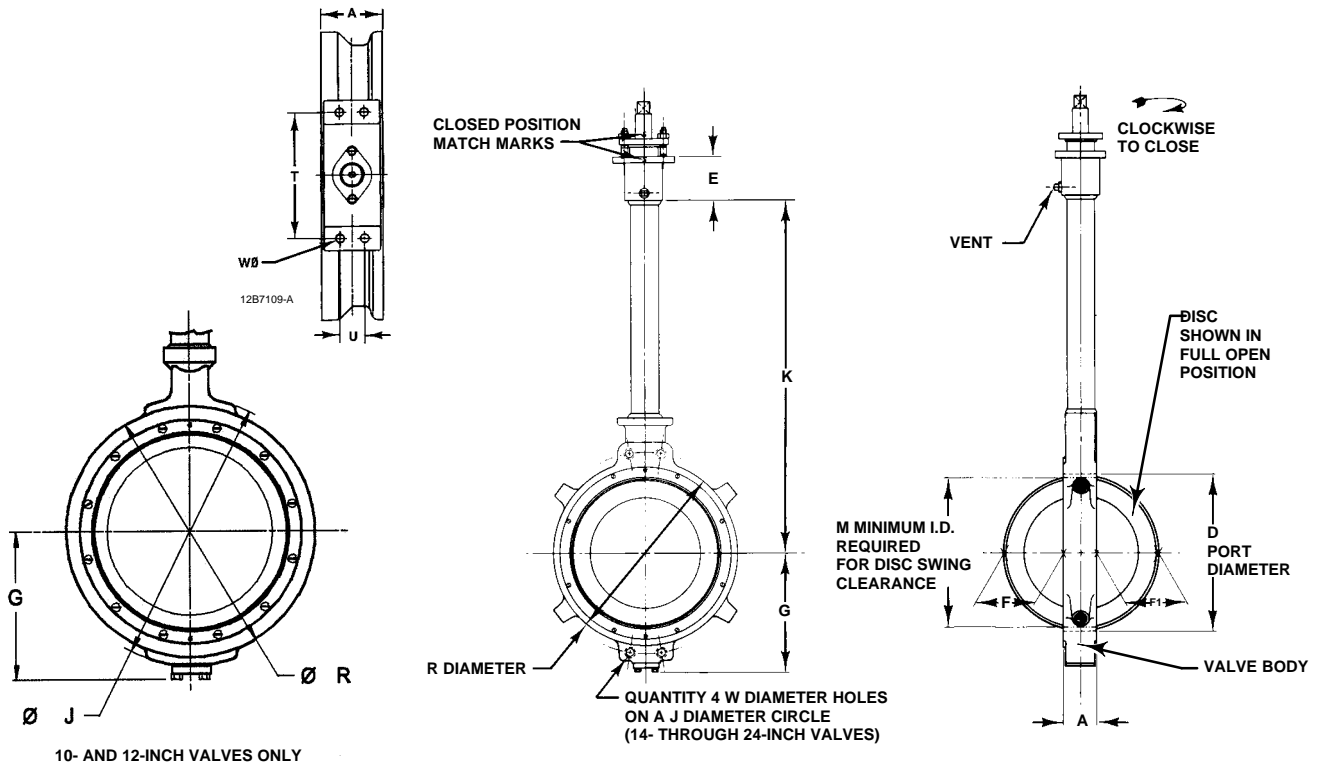

Figure 9. Dimensions, Single Flange Style Valves, ANSI Class 300, Sizes 3 through 6-Inch (also see table 6)

Table 7. Dimensions, Wafer Style Valve, ANSI Class 150, Sizes 10 through 24-Inch

VALVE SIZE, INCH	A ⁽¹⁾	D	E	F	F1	G	J	K	M ⁽²⁾	R	S ⁽³⁾	T	U	W
mm														
10	71	265	89	83	98	187	---	724	254	337	32	235	46.0	---
12	81	316	89	105	113	224	406	851	298	381	38	235	46.0	---
14	92	338	102	122	117	240	476	914	330	448	30.2	235	46.0	29
16	102	384	102	143	133	276	540	914	378	511	31.8	235	46.0	29
18	114	432	102	162	149	341	578	914	429	533	38.1	273	50.8	32
20	127	479	102	182	162	375	635	914	470	584	44.5	273	50.8	32
24	154	594	102	227	203	432	749	914	575	692	57.2	337	76.2	35
Inches														
10	2.82	10.44	3.5	3.25	3.81	7.38	---	28.5	10	13.25	1.25	9.25	1.81	---
12	3.19	12.44	3.5	4.13	4.44	8.82	16.0	33.5	11.75	15.0	1.5	9.25	1.81	---
14	3.6	13.3	4	4.80	4.61	9.45	18.75	36	13	17.64	1.1875	9.25	1.81	1.125
16	4	15.1	4	5.63	5.25	10.87	21.25	36	14.88	20.11	1.25	9.25	1.81	1.125
18	4.5	17	4	6.38	5.87	13.43	22.75	36	16.89	21	1.5	10.75	2.00	1.25
20	5	18.86	4	7.17	6.38	14.75	25	36	18.5	23	1.75	10.75	2.00	1.25
24	6.06	23.38	4	8.94	8	17	29.5	36	22.64	27.25	2.25	13.25	3.00	1.375

1. Face-to-face dimensions are in compliance with MSS SP68 and API 609 specifications.
 2. Minimum I.D. is the minimum pipe or flange I.D. required for disc swing clearance.
 3. Shaft diameter at key.



16B4210 / DOC
 A7244 / IL

Figure 10. Dimensions, Wafer Style Valve, ANSI Class 150, Sizes 10 through 24-Inch (see also table 7)

A31A Cryogenic Valve

Table 8. Dimensions, Single Flange Style Valve, ANSI Class 150, Sizes 10 through 24-Inch

VALVE SIZE, INCH	A ⁽¹⁾	D	E	F	F1	G	J	K	M ⁽²⁾	R	S ⁽³⁾	T	U	W
mm														
10	71	265	89	83	98	---	362	724	254	406	32	235	46.0	See thread information below
12	81	316	89	105	113	---	432	851	298	476	32	235	46.0	
14	92	338	102	122	117	240	476	914	330	533	30.2	235	46.0	
16	102	384	102	143	133	316	540	914	378	597	31.8	235	46.0	
18	114	432	102	162	149	341	578	914	429	635	38.1	273	50.8	
20	127	479	102	182	162	375	635	914	470	705	44.5	273	50.8	
24	154	594	102	227	203	432	749	914	575	813	57.2	337	76.2	
Inches														
10	2.82	10.44	3.5	3.25	3.82	---	14.25	28.5	10.0	16.0	1.25	9.25	1.81	0.875-9 12 holes
12	3.19	12.44	3.5	4.13	4.38	---	17.0	33.5	11.75	18.75	1.25	9.25	1.81	0.875-9 12 holes
14	3.62	13.30	4	4.8	4.60	9.45	18.75	36	13	21	1.1875	9.25	1.81	1-8 12 holes
16	4	15.12	4	5.63	5.25	12.44	21.25	36	14.88	23.5	1.25	9.25	1.81	1-8 16 holes
18	4.5	17	4	6.38	5.86	13.43	22.75	36	16.89	25	1.5	10.75	2.00	1.125-8 16 holes
20	5	18.85	4	7.17	6.38	14.75	25	36	18.50	27.75	1.75	10.75	2.00	1.125-8 20 holes
24	6.06	23.38	4	8.94	8	17	29.50	36	22.64	32	2.25	13.25	3.00	1.25-8 20 holes

1. Face-to-face dimensions are in compliance with MSS SP68 and API 609 specifications.
2. Minimum I.D. is the minimum pipe or flange I.D. required for disc swing clearance.
3. Shaft diameter at key.

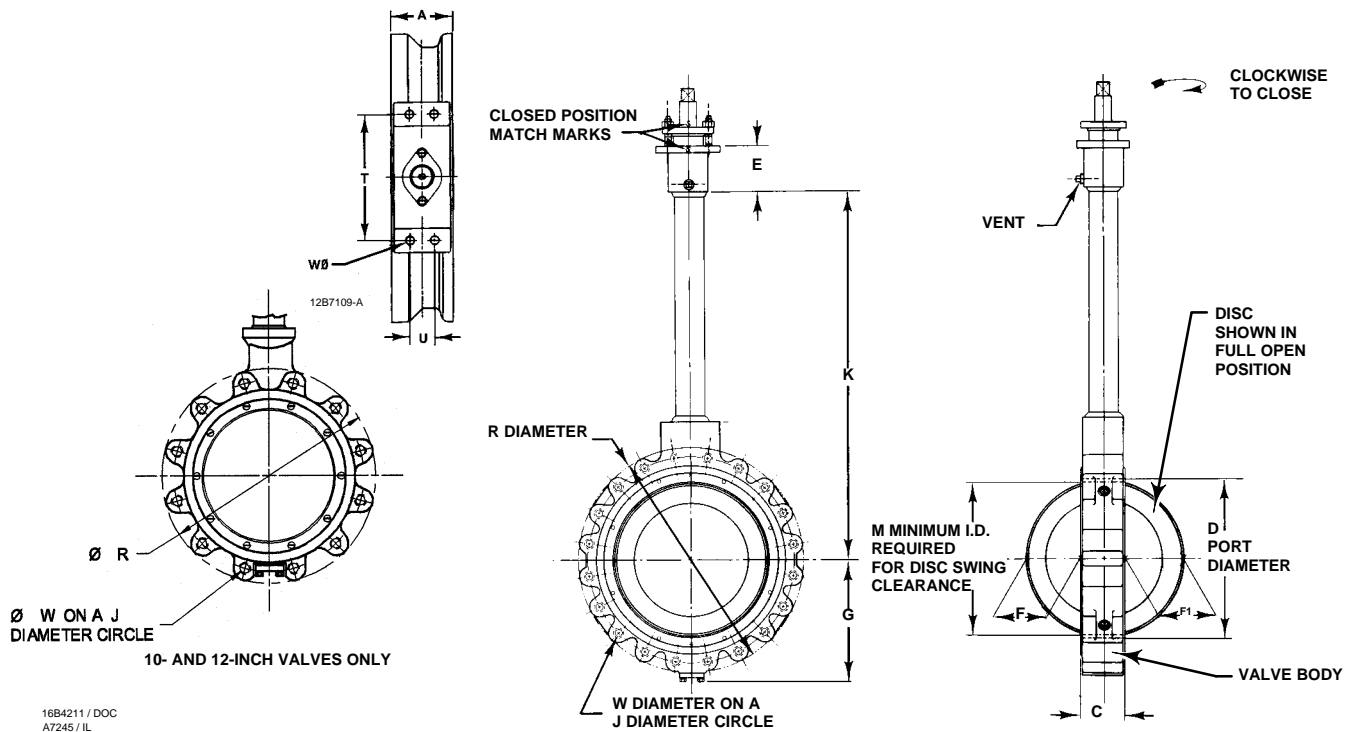

Figure 11. Dimensions, Single Flange Style Valve, ANSI Class 150, Sizes 10 through 24-Inch (see also table 8)

Table 9. Dimensions, Wafer Style Valve, ANSI Class 300, Sizes 8 through 24-Inch

VALVE SIZE, INCH	A ⁽¹⁾	D	E	F	F1	G	J	K	M ⁽²⁾	R	S ⁽³⁾	T	U	W
mm														
8	73	195	89	51	62	173	305	679	186	279	32	235	46.0	See thread information below
10	85	246	89	75	75	265	387	724	230	349	38	235	46.0	
12	94	292	89	93	99	281	451	851	282	394	44	273	50.8	
14	117	321	102	100	97	314	514	914	305	432	44.5	273	50.8	
16	133	367	102	117	105	348	572	914	349	489	44.5	273	50.8	
18	149	413	152	129	125	379	629	914	391	546	57.2	337	76.2	
20	159	468	152	149	146	410	686	914	442	600	69.9	337	76.2	
24	181	551	152	176	173	476	813	914	523	711	69.9	337	76.2	
Inches														
8	2.88	7.69	3.5	2.0	2.44	6.81	12.0	26.75	7.31	11.0	1.25	9.25	1.81	---
10	3.36	9.69	3.5	2.94	2.94	10.44	15.25	28.5	9.06	13.75	1.5	9.25	1.81	1-8
12	3.70	11.5	3.5	3.88	3.88	11.06	17.75	33.5	11.09	15.5	1.75	10.75	2.00	1.125-8
14	4.60	12.64	4	3.93	3.82	12.36	20.25	36	12	17	1.75	10.75	2.00	1.125-8
16	5.25	14.45	4	4.60	4.13	13.7	22.50	36	13.75	19.25	1.75	10.75	2.00	1.25-8
18	5.86	16.25	6	5.08	4.92	14.92	24.75	36	15.40	21.5	2.25	13.25	3.00	1.25-8
20	6.25	18.43	6	5.86	5.75	16.14	37	36	17.40	23.62	2.75	13.25	3.00	1.25-8
24	7.13	21.69	6	6.93	6.81	18.75	32	36	20.59	28	2.75	13.25	3.00	1.5-8

1. Face-to-face dimensions are in compliance with MSS SP68 and API 609 specifications.
 2. Minimum I.D. is the minimum pipe or flange I.D. required for disc swing clearance.
 3. Shaft diameter at key.

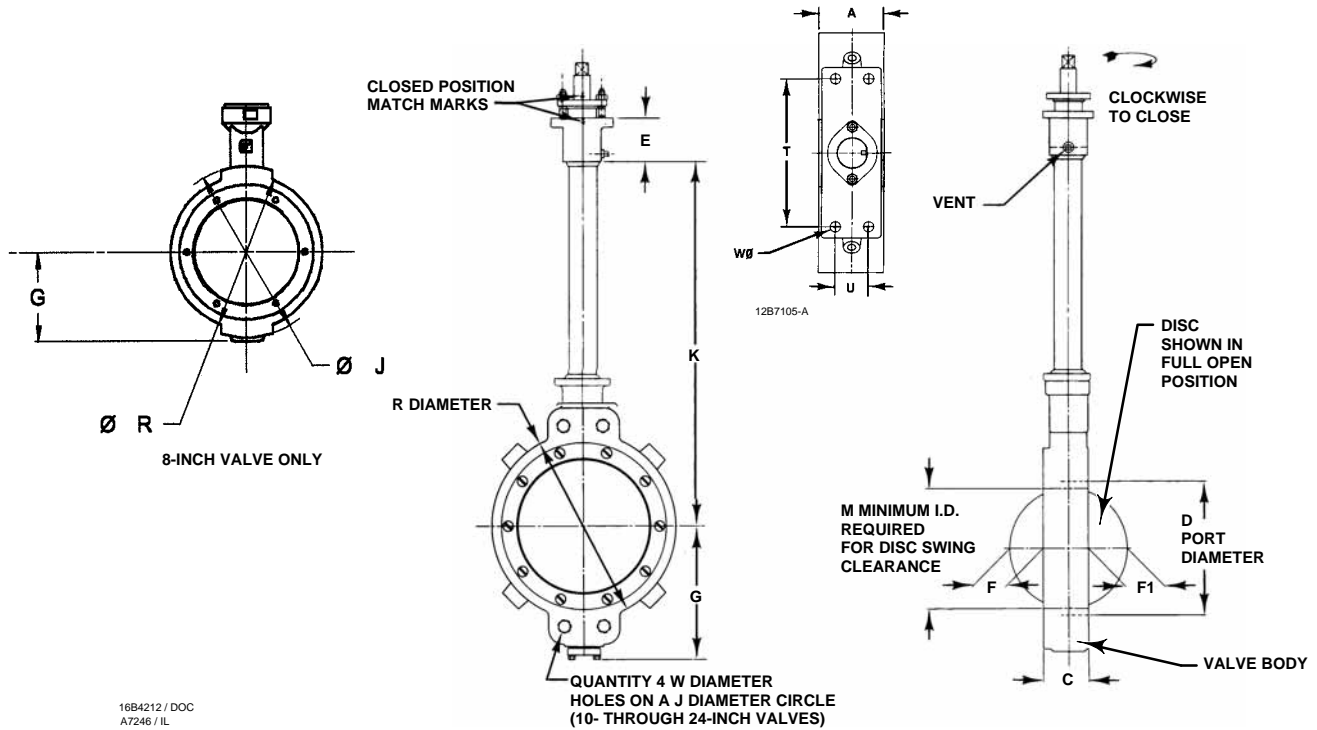

Figure 12. Dimensions, Wafer Style Valve, ANSI Class 300, Sizes 8 through 24-Inch (also see table 9)

A31A Cryogenic Valve

Table 10. Dimensions, Single Flange Style Valve, ANSI Class 300, Sizes 8 through 24-Inch

VALVE SIZE, INCH	A ⁽¹⁾	D	E	F	F1	G	J	K	M ⁽²⁾	R	S ⁽³⁾	T	U	W
mm														
8	73	195	89	51	62	214	330	679	186	375	32	235	46.0	See thread information below
10	85	246	89	75	75	265	387	724	230	438	38	235	46.0	
12	94	292	89	93	99	281	451	851	282	514	44	273	50.8	
14	117	321	102	100	97	314	514	914	305	584	44.5	273	50.8	
16	133	367	102	117	105	348	572	914	349	648	44.5	273	50.8	
18	149	413	152	129	125	379	629	914	391	711	57.2	337	76.2	
20	159	468	152	149	146	410	686	914	442	775	69.9	337	76.2	
24	181	551	152	176	173	476	813	914	523	914	69.9	337	76.2	
Inches														
8	2.88	7.69	3.5	2.0	2.44	8.44	13.0	26.75	7.32	14.75	1.25	9.25	1.81	0.875–9 12 holes
10	33.6	9.69	3.5	2.94	2.94	10.44	15.25	28.5	9.06	17.25	1.5	9.25	1.81	1–8 16 holes
12	3.70	11.5	3.5	3.69	3.88	11.06	17.75	33.5	11.09	20.25	1.75	10.75	2.00	1.125–8 16 holes
14	4.60	12.63	4	3.94	3.82	12.36	20.25	36	12	23	1.75	10.75	2.00	1.125–8 20 holes
16	5.25	14.45	4	4.60	4.13	13.70	22.50	36	13.75	25.5	1.75	10.75	2.00	1.25–8 20 holes
18	5	16.25	6	5.08	4.92	14.92	24.75	36	15.39	28	2.25	13.25	3.00	1.25–8 24 holes
20	6.25	18.43	6	5.87	5.75	16.14	37	36	17.40	30.5	2.75	13.25	3.00	1.25–8 24 holes
24	7.13	2121.69	6	6.93	6.81	18.75	32	36	20.59	36	2.75	13.25	3.00	1.5–8 24 holes
1. Face-to-face dimensions are in compliance with MSS SP68 and API 609 specifications. 2. Minimum I.D. is the minimum pipe or flange I.D. required for disc swing clearance. 3. Shaft diameter at key.														

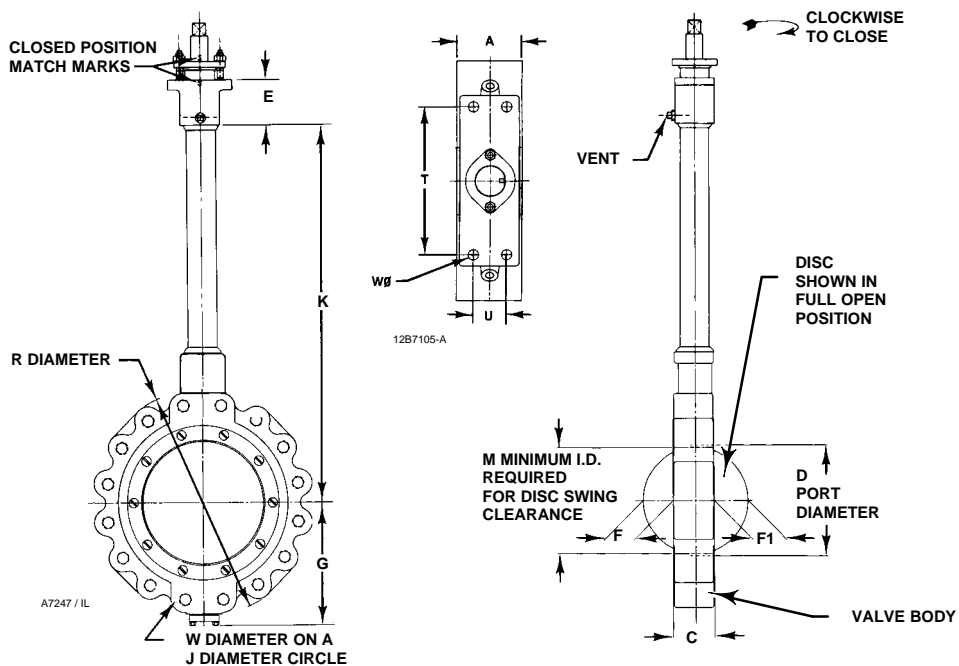

Figure 13. Dimensions, Single Flange Style Valve, ANSI Class 300, Sizes 8 through 24-Inch (also see table 10)

A31A Cryogenic Valve

Coefficients

Table 11. Type A31A Cryogenic-Valve Class 150, Reverse Flow, 3 through 18-Inch

Coefficients	Valve Size, Inches	Valve Rotation, Degrees								
		10	20	30	40	50	60	70	80	90
C _v	3	6	14	29	50	77	111	143	167	188
K _v		5.19	12.1	25.1	43.3	66.6	96.0	124	144	163
F _d		0.090	0.17	0.26	0.34	0.42	0.49	0.57	0.64	0.70
F _L		0.78	0.81	0.81	0.79	0.75	0.69	0.62	0.56	0.52
X _T		0.51	0.55	0.55	0.53	0.47	0.40	0.33	0.26	0.23
C _v	4	12	30	63	107	165	238	307	359	404
K _v		10.4	26.0	54.5	92.6	143	206	266	311	349
F _d		0.090	0.17	0.26	0.34	0.42	0.49	0.57	0.64	0.70
F _L		0.78	0.81	0.81	0.79	0.75	0.69	0.62	0.56	0.52
X _T		0.51	0.55	0.55	0.53	0.47	0.40	0.33	0.26	0.23
C _v	6	32	81	167	285	441	635	818	957	1080
K _v		27.7	70.1	144	247	381	549	708	828	934
F _d		0.090	0.17	0.26	0.34	0.42	0.49	0.57	0.64	0.70
F _L		0.78	0.81	0.81	0.79	0.75	0.69	0.62	0.56	0.52
X _T		0.51	0.55	0.55	0.53	0.47	0.40	0.33	0.26	0.23
C _v	8	34	113	248	429	677	1020	1420	1830	2260
K _v		29.4	97.7	215	371	586	882	1228	1583	1955
F _d		0.090	0.17	0.26	0.34	0.42	0.49	0.57	0.64	0.70
F _L		0.77	0.79	0.81	0.81	0.78	0.73	0.68	0.60	0.52
X _T		0.50	0.53	0.55	0.55	0.51	0.45	0.39	0.30	0.23
C _v	10	47	159	349	604	953	1430	2000	2580	3180
K _v		40.7	138	302	522	824	1237	1730	2232	2751
F _d		0.090	0.17	0.26	0.34	0.42	0.49	0.57	0.64	0.70
F _L		0.77	0.79	0.81	0.81	0.78	0.73	0.68	0.60	0.52
X _T		0.50	0.53	0.55	0.55	0.51	0.45	0.39	0.30	0.23
C _v	12	74	247	543	939	1480	2220	3110	4000	4940
K _v		64.0	214	470	812	1280	1920	2690	3460	4273
F _d		0.090	0.17	0.26	0.34	0.42	0.49	0.57	0.64	0.70
F _L		0.77	0.79	0.81	0.81	0.78	0.73	0.68	0.60	0.52
X _T		0.50	0.53	0.55	0.55	0.51	0.45	0.39	0.30	0.23
C _v	14	95	316	695	1200	1900	2840	3980	5120	6320
K _v		82.2	273	601	1038	1643	2457	3443	4429	5467
F _d		0.090	0.17	0.26	0.34	0.42	0.49	0.57	0.64	0.70
F _L		0.77	0.79	0.81	0.81	0.78	0.73	0.68	0.60	0.52
X _T		0.50	0.53	0.55	0.55	0.51	0.45	0.39	0.30	0.23
C _v	16	129	430	946	1640	2580	3870	5420	6970	8600
K _v		112	372	818	1419	2232	3348	4688	6029	7439
F _d		0.090	0.17	0.26	0.34	0.42	0.49	0.57	0.64	0.70
F _L		0.77	0.79	0.81	0.81	0.78	0.73	0.68	0.60	0.52
X _T		0.50	0.53	0.55	0.55	0.51	0.45	0.39	0.30	0.23
C _v	18	166	553	1220	2100	3320	4970	6960	8950	11,050
K _v		144	478	1055	1817	2872	4299	6020	7742	9558
F _d		0.090	0.17	0.26	0.34	0.42	0.49	0.57	0.64	0.70
F _L		0.77	0.79	0.81	0.81	0.78	0.73	0.68	0.60	0.52
X _T		0.50	0.53	0.55	0.55	0.51	0.45	0.39	0.30	0.23

Table 12. Type A31A Cryogenic-Valve Class 150, Reverse Flow, 20 and 24-Inch

Coefficients	Valve Size, Inches	Valve Rotation, Degrees								
		10	20	30	40	50	60	70	80	90
C _v	20	208	692	1520	2630	4160	6230	8730	11,220	13,850
K _v		180	599	1315	2275	3598	5389	7551	9705	11,980
F _d		0.090	0.17	0.26	0.34	0.42	0.49	0.57	0.64	0.70
F _L		0.77	0.79	0.81	0.81	0.78	0.73	0.68	0.60	0.52
X _T		0.50	0.53	0.55	0.55	0.51	0.45	0.39	0.30	0.23
C _v	24	322	1080	2370	4080	6450	9670	13,540	17,410	21,500
K _v		277	934	2050	3529	5579	8365	11,712	15,060	18,598
F _d		0.090	0.17	0.26	0.34	0.42	0.49	0.57	0.64	0.70
F _L		0.77	0.79	0.81	0.81	0.78	0.73	0.68	0.60	0.52
X _T		0.50	0.53	0.55	0.55	0.51	0.45	0.39	0.30	0.23

A31A Cryogenic Valve

Table 13. Type A31A Cryogenic-Valve Class 300, Reverse Flow, 3 through 18-Inch

Coefficients	Valve Size, Inches	Valve Rotation, Degrees								
		10	20	30	40	50	60	70	80	90
C _v	3	6	14	29	50	77	111	143	167	188
K _v		5.19	12.1	25.1	43.3	66.6	96.0	124	144	163
F _d		0.090	0.17	0.26	0.34	0.42	0.49	0.57	0.64	0.70
F _L		0.78	0.81	0.81	0.79	0.75	0.69	0.62	0.56	0.52
X _T		0.51	0.55	0.55	0.53	0.47	0.40	0.33	0.26	0.23
C _v	4	12	30	63	107	165	238	307	359	404
K _v		10.4	26.0	54.5	92.6	143	206	266	311	349
F _d		0.090	0.17	0.26	0.34	0.42	0.49	0.57	0.64	0.70
F _L		0.78	0.81	0.81	0.79	0.75	0.69	0.62	0.56	0.52
X _T		0.51	0.55	0.55	0.53	0.47	0.40	0.33	0.26	0.23
C _v	6	32	81	167	285	441	635	818	957	1080
K _v		27.7	70.1	144	247	381	549	708	828	934
F _d		0.090	0.17	0.26	0.34	0.42	0.49	0.57	0.64	0.70
F _L		0.78	0.81	0.81	0.79	0.75	0.69	0.62	0.56	0.52
X _T		0.51	0.55	0.55	0.53	0.47	0.40	0.33	0.26	0.23
C _v	8	40	100	206	352	545	784	1010	1180	1330
K _v		34.6	86.5	178	304	471	677	874	1020	1150
F _d		0.090	0.17	0.26	0.34	0.42	0.49	0.57	0.64	0.70
F _L		0.78	0.81	0.81	0.79	0.75	0.69	0.62	0.56	0.52
X _T		0.51	0.55	0.55	0.53	0.47	0.40	0.33	0.26	0.23
C _v	10	71	178	367	628	971	1400	1800	2110	2370
K _v		61.4	154	317	543	840	1211	1557	1825	2050
F _d		0.090	0.17	0.26	0.34	0.42	0.49	0.57	0.64	0.70
F _L		0.78	0.81	0.81	0.79	0.75	0.69	0.62	0.56	0.52
X _T		0.51	0.55	0.55	0.53	0.47	0.40	0.33	0.26	0.23
C _v	12	110	276	570	975	1510	2170	2800	3280	3680
K _v		95.2	239	493	843	1306	1877	2422	2837	3183
F _d		0.090	0.17	0.26	0.34	0.42	0.49	0.57	0.64	0.70
F _L		0.78	0.81	0.81	0.79	0.75	0.69	0.62	0.56	0.52
X _T		0.51	0.55	0.55	0.53	0.47	0.40	0.33	0.26	0.23
C _v	14	136	341	704	1200	1860	2680	3450	4050	4550
K _v		118	295	609	1038	1609	2318	2984	3503	3936
F _d		0.090	0.17	0.26	0.34	0.42	0.49	0.57	0.64	0.70
F _L		0.78	0.81	0.81	0.79	0.75	0.69	0.62	0.56	0.52
X _T		0.51	0.55	0.55	0.53	0.47	0.40	0.33	0.26	0.23
C _v	16	169	422	873	1490	2310	3320	4280	5010	5630
K _v		146	365	755	1289	1998	2872	3702	4334	4870
F _d		0.090	0.17	0.26	0.34	0.42	0.49	0.57	0.64	0.70
F _L		0.78	0.81	0.81	0.79	0.75	0.69	0.62	0.56	0.52
X _T		0.51	0.55	0.55	0.47	0.40	0.33	0.26	0.26	0.23
C _v	18	247	617	1280	2180	3370	4860	6260	7330	8230
K _v		214	534	1107	1886	2915	4204	5415	6340	7119
F _d		0.090	0.17	0.26	0.34	0.42	0.49	0.57	0.64	0.70
F _L		0.78	0.81	0.81	0.79	0.75	0.69	0.62	0.56	0.52
X _T		0.51	0.55	0.55	0.53	0.47	0.40	0.33	0.26	0.23

Table 14. Type A31A Cryogenic-Valve Class 300, Reverse Flow, 20- and 24-Inch

Coefficients	Valve Size, Inches	Valve Rotation, Degrees								
		10	20	30	40	50	60	70	80	90
C _v	20	286	714	1480	2520	3910	5620	7240	8480	9530
K _v		247	618	1280	2180	3382	4861	6263	7335	8243
F _d		0.090	0.17	0.26	0.34	0.42	0.49	0.57	0.64	0.70
F _L		0.78	0.81	0.81	0.79	0.75	0.69	0.62	0.56	0.52
X _T		0.51	0.55	0.55	0.53	0.47	0.40	0.33	0.26	0.23
C _v	24	375	938	1940	3320	5130	7380	9510	11,140	12,500
K _v		324	811	1678	2872	4437	6384	8226	9636	10,821
F _d		0.090	0.17	0.26	0.34	0.42	0.49	0.57	0.64	0.70
F _L		0.78	0.81	0.81	0.79	0.75	0.69	0.62	0.56	0.52
X _T		0.51	0.55	0.55	0.53	0.47	0.40	0.33	0.26	0.23

POSI-SEAL, NOVEX, and Fisher are marks owned by Fisher Controls International LLC, a member of the Emerson Process Management business division of Emerson Electric Co. The Emerson logo is a trademark and service mark of Emerson Electric Co. All other marks are the property of their respective owners.

The contents of this publication are presented for informational purposes only, and while every effort has been made to ensure their accuracy, they are not to be construed as warranties or guarantees, express or implied, regarding the products or services described herein or their use or applicability. We reserve the right to modify or improve the designs or specifications of such products at any time without notice.

Fisher does not assume responsibility for the selection, use or maintenance of any product. Responsibility for proper selection, use and maintenance of any Fisher product remains solely with the purchaser and end-user.

Emerson Process Management

Fisher

Marshalltown, Iowa 50158 USA
Cernay 68700 France
Sao Paulo 05424 Brazil
Singapore 128461

www.Fisher.com

