

Fisher[®] POSI-SEAL[™] A11 High-Performance Butterfly Valve

The Fisher A11 High-Performance Butterfly Valve (figure 1) maintains tight shutoff, and can be specified for a wide range of pressure and temperature conditions, including cryogenic applications.

The A11 valve is available in either a wafer or a single-flange design. A square or keyed shaft can combine with a variety of handlevers, handwheels, or pneumatic piston diaphragm actuators. A splined shaft can combine with a variety of spring-and-diaphragm or pneumatic piston actuators. These combinations help make the A11 valve a reliable, high-performance butterfly valve for both throttling and on-off applications in the process industries.

The A11 valve can be supplied with one of several dynamic seals (figure 2) that can be used in a variety of demanding applications. With the appropriate seal selection and materials of construction, the pressure-assisted seal helps provide excellent shutoff against the full ASME class pressure range for the A11 valve.

Contents

Features	2
Specifications	3
Standard Seal Configurations	4
Installation	5
Pressure Drops	11
Coefficients	29
Tables	
Temperature Limits for Metal Seal	5
Material Temperature Ranges	6
Trim Descriptions	7
Valve/Actuator Combinations	10
Maximum Shutoff Pressure Drops	11
Dimensions and Weights	20

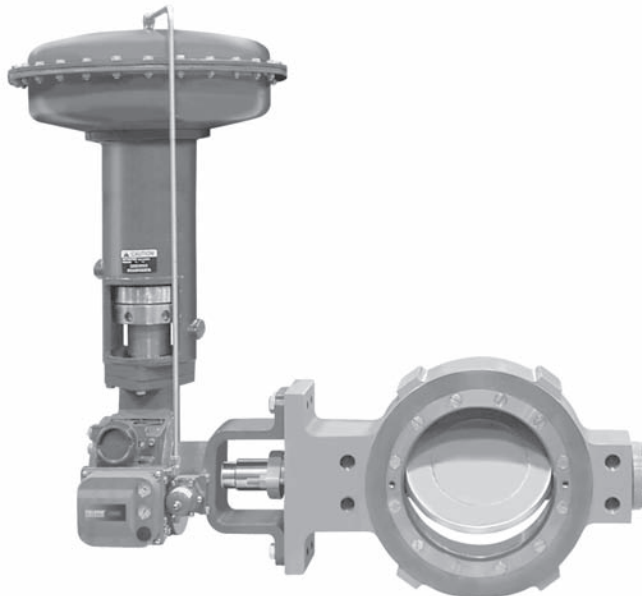

W9529-1

Figure 1. Fisher POSI-SEAL A11 Valve with 1052 Actuator



Features

- **Shaft Versatility**— This valve will meet your actuator needs with a choice of square, keyed, or splined shaft connections.

- **Excellent Shutoff Integrity**—The pressure-assisted seal design provides tight shutoff and permits the use of smaller, less expensive actuators in applications requiring full ASME B16.34 shutoff capabilities.

- **Excellent Emissions Capabilities**— The optional ENVIRO-SEAL™ packing systems, are designed with very smooth shaft surfaces and live-loading to provide improved sealing, guiding, and loading force transmission. The seal of the ENVIRO-SEAL system can control emissions to below 100 ppm (parts per million).

- **Sour Service Capability**— Trim and bolting materials are available for applications involving sour liquids and gases. These constructions comply with NACE MR0175-2002, MR0103, and MR0175 / ISO 15156.

- **High-Temperature/Cryogenic Capabilities**— Optional valve constructions allow this valve to meet both high-temperature and cryogenic applications (see table 7 for cryogenic and high-temperature actuator configurations).

- **Easy Installation**—The valve body self-centers on the line flange bolts as a fast, accurate means of centering the valve in the pipeline.

- **Reliable Flange Gasketing Surface**—Seal retainer screws are located so there is no interference with the sealing function of either flat sheet or spiral wound line flange gaskets.

- **True Bidirectional Shutoff Performance**—A feature of the valve design is that the torque necessary to open and close the valve is the same regardless of the direction in which the differential pressure is applied.

- **Ease of Maintenance**—Interchangeability of all parts, including shafts and discs, simplifies service and reduces maintenance costs.

Specifications

Available Configurations and Sizes

- Flangeless (wafer) or ■ Single-flange (lugged)
- Available Sizes and Shaft Styles*

PRESSURE RATING	VALVE SIZE, NPS		
	Keyed	Square	Splined
CL150/150 ⁽¹⁾	30 to 72	---	---
CL150	30 to 72	---	---
CL300	30 to 72	---	---
CL600	14 to 48 (standard), 3 to 12 (optional)	3 to 12 (standard)	3 to 24 (optional)
CL900	12 to 24 (standard), 6 to 10 (optional)	6 to 10 (standard)	Consult your Emerson Process Management sales office
CL1500	10 to 20 (standard)	---	
CL2500	Consult your Emerson Process Management Sales Office		

1. Refers to a valve construction consisting of a CL150 body and trim suitable for a shutoff pressure drop of 150 psid.

End Connection Style

Flangeless or single flange style designed to fit between raised-face mating flanges of appropriate class pressure rating.

ASME B16.5

- NPS 3 through 24: CL600*
- NPS 6 through 24: CL900*
- NPS 10 through 20: CL1500*

ASME B16.47 Class A and MSS-SP-44

- NPS 30 through 48: CL150, 300, and 600*
- NPS 30 through 36: CL900*

Consult your Emerson Process Management sales office for valves compatible with API 605 and ASME B16.47 Class B flanges

Maximum Inlet Pressure⁽¹⁾

Valve Body: Consistent with CL150, 300, 600, 900, and 1500 pressure/temperature ratings per ASME B16.34, see table 8.

Seal: see figure 2

Materials of Construction

See table 2.

Disc Hard Surfacing: All CL600, 900, and 1500 disc edges must be coated, regardless of the seal type. Metal, NOVEX, Phoenix III and cryogenic

seals require the disc to be coated, regardless of the valve class.

Maximum Temperature Capabilities⁽¹⁾

See table 2

High-Temperature and Cryogenic

Applications: See table 7 for available valve and actuator combinations

Shutoff Classification per ANSI/FCI 70-2 and IEC 60534-4

Standard Soft Seal: Bubble-tight shutoff (exceeds Class VI)

Metal Seal: 20% of Class IV (reverse direction only)

NOVEX Seal: Standard Class V (Class VI optional, reverse direction only)

Phoenix III Seal: Bubble-tight (reverse direction only), Class VI (forward direction only)

High Pressure Seal: Standard Class V (Class VI optional, reverse direction only)

Cryogenic Seal (Reverse direction only):

NOVEX: Class VI

CTFE: 10% of Class IV

CTFE with Aluminum Backup Ring: Class VI

Flow Characteristic

Modified equal percentage

Flow Coefficients

See this bulletin's Coefficients section, or Catalog 12

Noise Levels

See Catalog 12 for sound pressure level prediction

Available Actuators

Handlever; handwheel; or pneumatic piston, spring return, double-acting, spring and diaphragm

Disc Rotation

Clockwise (CW) to close

Valve Dimensions and Approximate Weights

See figures 4, 5, 6, 7 and 8

For general packing guidelines, see Bulletin 59.3:042 Packing Selection Guidelines for Rotary Valves, D102093X012

For information on ENVIRO-SEAL packing system see Bulletin 59.3:041 ENVIRO-SEAL Packing Systems for Rotary Valves, D101638X012

1. The pressure/temperature limits in this bulletin, and any applicable code or standard limitation, should not be exceeded.

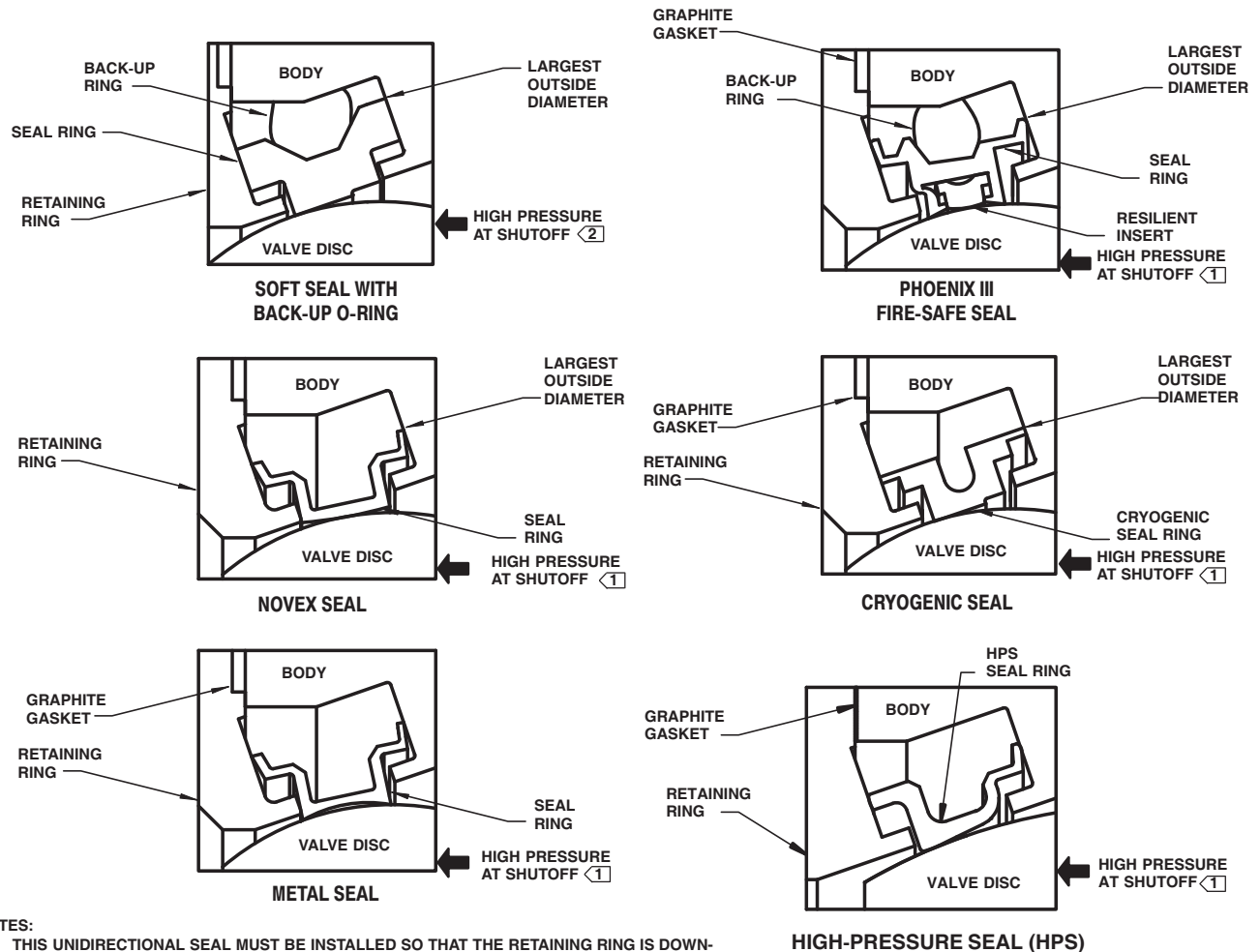

NOTES:

- 1 THIS UNIDIRECTIONAL SEAL MUST BE INSTALLED SO THAT THE RETAINING RING IS DOWNSTREAM FROM THE HIGH PRESSURE SIDE OF THE VALVE AT SHUTOFF, AS SHOWN.
- 2 FOR THIS BIDIRECTIONAL SEAL, THE "PREFERRED" VALVE ORIENTATION PLACES THE RETAINING RING DOWNSTREAM FROM THE HIGH PRESSURE SIDE OF THE VALVE AT SHUTOFF.

E0578 / IL

Figure 2. Available Seal Configurations

Standard Seal Configurations

- **Standard Soft Seal (PTFE CL150 and 300, and ETFE CL600, 900, and 1500)**—A resilient dynamic seal with an elastomeric back-up ring for low to moderate temperature applications.

- **Metal Seal**—This stainless steel seal is available for severe service and high-temperature applications to 704°C (1300°F) for NACE applications and 816°C (1500°F) for other applications.

- **NOVEX Seal**—The NOVEX stainless steel seal is available for severe service, Cryogenic, and high-temperature applications to 816°C (1500°F).

Available for CL150/150, 150, and 300, up to NPS 36 only.

- **Phoenix III Seal**—This three-component, metal-and-polymeric seal is available for severe service with low to moderate temperature applications.

- **High-Pressure Seal (CL600, 900, and 1500)**—This robust, stainless steel seal is available for severe service, cryogenic, and high-temperature applications to 704°C (1300°F), for NACE, and for other applications to 816°C (1500°F).

- **Cryo-Tight Cryogenic Seal**—This resilient dynamic seal is available with or without an aluminum back-up ring for low temperature applications.

Table 1. Temperature Limits for Metal Seal

SEAL TYPE	PRESSURE RATING	SEAL MATERIAL	MAXIMUM TEMPERATURE LIMITS		BACKUP RING	
			°C	°F		
Metal	CL150/150, and 150 ⁽²⁾	S31600 w/ CF8M disc	538	1000	No	
		S31600 w/ WCC disc ⁽²⁾	232	450		
	300 ⁽²⁾	S31600 w/ CF8M disc	816	1500	No	
		S31600 w/ WCC disc ⁽²⁾	232	450		
	600 ^(1, 2)	S21800 w/ CF8M disc	S21800 w/ WCC disc	816	1500	No
			S20910 NACE w/ CF8M disc	649	1200	No
S20910 w/ WCC disc		232	450	No		
S17400 H1150M w/ CF8M disc		232	450	No		
S17400 H1150M w/ WCC disc	427	800	No			

1. When used with CF8M discs, S20910 is the preferred seal material. When used with WCC discs, S17400 H1150M is the preferred material.
2. For valves with WCC discs at temperatures over 254°C (450°F), contact your Emerson Process Management sales office for seal material selection.

Installation

Preferred valve orientation for the A11 valve is reverse flow direction. Reverse flow direction is into the side of the valve body opposite the retaining ring or into the shaft side of the disc.

For erosive and many severe service applications, valves with bidirectional seals can and should be installed with the shaft horizontal and in the forward flow direction to prevent direct impingement of the process media on the seal, and to minimize the exposure of the shaft bearings to the process media.

The standard soft seal and the Phoenix III seal both offer bidirectional shutoff. Valves using either metal, NOVEX, or cryogenic seals are unidirectional and must be installed in the reverse flow orientation.

For assistance in selecting the appropriate combination of actuator action and open valve position, consult your Emerson Process Management sales office.

Dimensions and weights for wafer-style and single-flange valves are shown in figures 4, 5, 6, 7 and 8.

Table 2. Material Temperature Ranges

PART NAME	MATERIAL	TEMP °C	TEMP °F
Valve Body ⁽¹⁾	WCC Steel, SA-516-70 or SA-105	-29 to 427	-20 to 800
	CF8M, CF8, CF3M, CF3	-254 to 538	-425 to 1000
	CF8M, CF8C, CF8 ⁽²⁾ FMS 20B16 a Fisher material standard (0.04% min carbon)	over 538 to 816	over 1000 to 1500
	LCC	-45 to 343	-50 to 650
	C12A	-29 to 649	-20 to 1200
	WC9	-29 to 593	-20 to 1100
	CG8M, CG3M, CF8C	-198 to 538	-325 to 1000
Disc ⁽⁵⁾	WCC Steel	-29 to 427	-20 to 800
	CF8M, CF8, CF3M, CF3	-254 to 538	-425 to 1000
	CF8M, CF8C, CF8 ⁽²⁾ FMS 20B16 a Fisher material standard (0.04% min carbon)	over 538 to 816	over 1000 to 1500
	CB7Cu-1	-29 to 427	-20 to 800
Disc Seating Surface Coating	CG8M, CG3M, CF8C	-198 to 538	-325 to 1000
	Chrome Plating	-254 to 316	-425 to 600
	Chrome Coating ⁽⁴⁾	-254 to 593	-425 to 1100
	Electroless Nickel Coating (ENC)	-254 to 538	-425 to 1000
	Chromium Carbide Coating	-254 to 816	-425 to 1500
CoCr-A (Alloy 6) ⁽⁴⁾			
Shaft	S17400 (H1025)	-73 to 427	-100 to 800
	S17400 (H1150M)	-196 to 427	-320 to 800
	N05500	-254 to 482	-425 to 900
	N07718	-254 to 704	-425 to 1300
	S20910	-254 to 593	-320 to 1100
	N07750 ⁽⁴⁾	over 593 to 816	over 1100 to 1500
Bearings ⁽³⁾	PEEK	-73 to 260	-100 to 500
	PTFE Composition ⁽⁴⁾	-254 to 163	-425 to 325
	S31600 (316 SST Nitrided)	-254 to 816	-425 to 1500
	R30006 (Alloy 6) ⁽⁴⁾		
	Bronze ⁽⁴⁾	-254 to 302	-425 to 575
	PTFE Lined N04400 ⁽⁴⁾	-254 to 232	-425 to 450
Seal Ring	Soft - PTFE	-62 to 232	-80 to 450
	Soft - ETFE	-54 to 149	-65 to 300
	Metal - All	See table 1	
	HPS - S20910	-254 to 649	-425 to 1200
	HPS - S21800	-254 to 816	-425 to 1500
Backup Ring	Used with Soft Seal		
	Fluorocarbon	-29 to 204	-20 to 400
	EPR	-54 to 182	-65 to 360
	Nitrile ⁽⁴⁾	-29 to 93	-20 to 200
	Chloroprene ⁽⁴⁾	-43 to 149	-45 to 300
	Used with Phoenix III Seal		
	Fluorocarbon	-40 to 232	-40 to 450
	EPR	-62 to 204	-80 to 400
	Nitrile ⁽⁴⁾	-40 to 149	-40 to 300
	Chloroprene ⁽⁴⁾	-54 to 149	-65 to 300
	Used with Cryogenic Seal		
	Aluminum ⁽⁴⁾	-254 to 149	-425 to 300
Packing	PTFE V-Ring	-254 to 232	-425 to 450
	PTFE ENVIRO-SEAL	-254 to 232	-425 to 450
	Square Ring Graphite for Oxidizing Service	-254 to 538	-425 to 1000
	Square Ring Graphite for Non-oxidizing Service	-254 to 816	-425 to 1500
	Graphite ENVIRO-SEAL	-140 to 315	-325 to 600

1. Special gasket retainer bolts are required for over 538°C (1000° F).
 2. Special retaining ring screws for single flange valves over 538°C (1000° F).
 3. Special thrust bearings are required for high temperature applications over 343°C (650° F) (with 6 and 12 inch extensions). Constructions with carbon steel valves and SST discs may require special thrust bearings at temperatures greater than 343°C (650° F).
 4. Special option; contact your Emerson Process Management sales office.
 5. For valves NPS 30 and larger at temperatures over 254°C (450° F), the disc material should be the same as the valve body material.

Product Bulletin

21.1:A11
April 2010

A11 Valve

Table 3. Trim Descriptions - CL600

Trim Type	Trim Number	Temperature Range	Disc Material	Disc Edge Coating	Seal Type	Seal Material	Shaft	Bearings	Packing
Standard	500 ⁽¹⁾	-29 to 149°C -20 to 300°F	CF8M	Chrome Plated	Soft	ETFE	S17400 H1025	PEEK	PTFE
	501	-29 to 149°C -20 to 300°F	CF8M	Electroless Nickel Coating	Soft	ETFE	S17400 H1025	PEEK	PTFE
	502	-46 to 232°C -50 to 450°F	CF8M	Chrome Plated	Metal	S20910	S17400 H1025	PEEK	PTFE
	503	-46 to 232°C -50 to 450°F	CF8M	Electroless Nickel Coating	Metal	S20910	S17400 H1025	PEEK	PTFE
	504	-40 to 149°C -40 to 300°F	CF8M	Chrome Plated	Phoenix III	S31600/ETFE	S17400 H1025	PEEK	PTFE
	505	-46 to 316°C -50 to 600°F	CF8M	Chrome Plated	Metal	S20910	S17400 H1025	316 SST Nitrided	Graphite
	506 ⁽²⁾	-46 to 427°C -50 to 800°F	CF8M	Chromium Carbide Coating	Metal	S20910	S17400 H1025	316 SST Nitrided	Graphite
NACE ⁽⁶⁾	508	-29 to 149°C -20 to 300°F	CF8M	Chrome Plated	Soft	ETFE	S17400 H1150M	PEEK	PTFE
	509	-46 to 232°C -50 to 450°F	CF8M	Chrome Plated	Metal	S20910	S17400 H1150M	PEEK	PTFE
	510 ⁽²⁾	-46 to 427°C -50 to 800°F	CF8M	Chromium Carbide Coating	Metal	S20910	S17400 H1150M	316 SST Nitrided	Graphite
	511 ⁽²⁾	-46 to 482°C -50 to 900°F	CF8M	Chromium Carbide Coating	Metal	S20910	N05500	316 SST Nitrided	Graphite
	512 ⁽²⁾	-46 to 538°C -50 to 1000°F	CF8M	Chromium Carbide Coating	Metal	S20910	S20910	316 SST Nitrided	Graphite
	513 ⁽²⁾	-46 to 538°C -50 to 1000°F	CF8M	Chromium Carbide Coating	Metal	S20910	N07718	316 SST Nitrided	Graphite
High-Temperature	514H ⁽³⁾	343 to 427°C 650 to 800°F	CF8M	Chromium Carbide Coating	Metal	S20910	S17400 H1025	316 SST Nitrided	Graphite
	515H ⁽³⁾	427 to 538°C 800 to 1000°F	CF8M	Chromium Carbide Coating	Metal	S20910	N07718	316 SST Nitrided	Graphite
	516H ⁽⁴⁾	538 to 704°C 1000 to 1300°F	CF8M	Chromium Carbide Coating	Metal	S21800	N07718	316 SST Nitrided	Graphite
Cryogenic	517C ⁽⁵⁾	-196 to 163°C -320 to 325°F	CF8M	Chrome Plated	HPS	S20910 Nitrided	S17400 H1150M	PTFE Composition	PTFE
	518C ⁽⁵⁾	-196 to 149°C -320 to 300°F	CF8M	Chrome Plated	Cryogenic	CTFE	S17400 H1150M	PTFE Composition	PTFE

1. Trim 500 is furnished as standard trim in all CL600 A11 valves.
2. If operating temperature is above 343°C (650°F), see table 7 for available actuator configurations.
3. Trim includes 6-inch shaft extension.
4. Trim includes 12-inch shaft extension.
5. Trim includes Cryogenic shaft extension, see table 6 for extension length.
6. NACE MR0175-2002 and MR0103. For NACE MR0175-2003, or MR0175/ISO 15156 consult your Emerson Process Management sales office for material selection and pricing.

Table 4. Trim Descriptions - CL900 and CL1500

Trim Type	Trim Number	Temperature Range	Disc Material	Disc Edge Coating	Seal Type	Seal Material	Shaft	Bearings	Packing ⁽⁷⁾
Standard	500 ⁽¹⁾	-29 to 149°C -20 to 300°F	CB7Cu-1	Chrome Plated	Soft	ETFE	S17400 H1025	PEEK	PTFE
	502	-46 to 232°C -50 to 450°F	CB7Cu-1	Chrome Plated	HPS	S20910 Nitrided	S17400 H1025	PEEK	PTFE
	504	-40 to 149°C -40 to 300°F	CB7Cu-1	Chrome Plated	Phoenix III	S31600/ETFE	S17400 H1025	PEEK	PTFE
	505	-46 to 316°C -50 to 600°F	CB7Cu-1	Chrome Plated	HPS	S20910 Nitrided	S17400 H1025	316 SST Nitrided	Graphite
	506 ⁽²⁾	-46 to 427°C -50 to 800°F	CB7Cu-1	Chromium Carbide Coating	HPS	S20910 Nitrided	S17400 H1025	316 SST Nitrided	Graphite
NACE ⁽⁵⁾	508	-29 to 149°C -20 to 300°F	CB7Cu-1	Chrome Plated	Soft	ETFE	S17400 H1150M	PEEK	PTFE
	509	-46 to 232°C -50 to 450°F	CB7Cu-1	Chrome Plated	HPS	S20910 Nitrided	S17400 H1150M	PEEK	PTFE
	510 ⁽²⁾	-46 to 427°C -50 to 800°F	CB7Cu-1	Chromium Carbide Coating	HPS	S20910 Nitrided	S17400 H1150M	316 SST Nitrided	Graphite
	511 ⁽²⁾	-46 to 482°C -50 to 900°F	CF8M	Chromium Carbide Coating	HPS	S20910 Nitrided	N05500	316 SST Nitrided	Graphite
	512 ⁽²⁾	-46 to 538°C -50 to 1000°F	CF8M	Chromium Carbide Coating	HPS	S20910 Nitrided	S20910	316 SST Nitrided	Graphite
	513 ⁽²⁾	-46 to 538°C -50 to 1000°F	CF8M	Chromium Carbide Coating	HPS	S20910 Nitrided	N07718	316 SST Nitrided	Graphite
High-Temperature	514H ⁽³⁾	343 to 427°C 650 to 800°F	CB7Cu-1	Chromium Carbide Coating	HPS	S20910 Nitrided	S17400 H1025	316 SST Nitrided	Graphite
	515H ⁽³⁾	427 to 538°C 800 to 1000°F	CF8M	Chromium Carbide Coating	HPS	S20910 Nitrided	N07718	316 SST Nitrided	Graphite
	516H ⁽⁴⁾	538 to 704°C 1000 to 1300°F	CF8M	Chromium Carbide Coating	HPS	S21800 Nitrided	N07718	316 SST Nitrided	Graphite
Cryogenic	517C ⁽⁶⁾	-196 to 163°C -320 to 325°F	CF8M	Chrome Plated	HPS	S20910 Nitrided	S17400 H1150M	PTFE Composition	PTFE

1. Trim 500 is furnished as standard trim in all CL1500 A11 valves.
2. If operating temperature is above 343°C (650°F), see table 7 for available actuator configurations.
3. Trim includes 6-inch shaft extension.
4. Trim includes 12-inch shaft extension.
5. NACE MR0175-2002 and MR0103. For NACE MR0175-2003, or MR0175/ISO 15156 consult your Emerson Process Management sales office for material selection and pricing.
6. Trim includes Cryogenic shaft extension, see table 6 for extension length. Valve may require extension on both ends of the valve body, consult your Emerson Process Management sales office for details.
7. Consult Fisher bulletin 59.3:042 (D102093X012) for packing selection guidelines regarding pressure/temperature limits.

Product Bulletin

21.1:A11
April 2010

A11 Valve

Table 5. Trim Descriptions - CL150/150, CL150, and CL300

Trim Type	Trim Number	Temperature Range	Disc Material	Disc Edge Coating	Seal Type	Seal Material	Shaft	Bearings	Packing
Standard	550 ⁽¹⁾	-29 to 204°C -20 to 400°F	CF8M or WCC	None	Soft	PTFE	S17400 H1025	PEEK	PTFE
	552	-46 to 232°C -50 to 450°F	CF8M or WCC	Chrome Plated	NOVEX ⁽⁷⁾	S31600	S17400 H1025	PEEK	PTFE
	553	-46 to 232°C -50 to 450°F	CF8M or WCC	Electroless Nickel Coating	NOVEX ⁽⁷⁾	S31600	S17400 H1025	PEEK	PTFE
	554	-40 to 232°C -40 to 450°F	CF8M or WCC	Chrome Plated	Phoenix III	S31600/PTFE	S17400 H1025	PEEK	PTFE
	555	-46 to 316°C -50 to 600°F	CF8M or WCC	Chrome Plated	NOVEX ⁽⁷⁾	S31600	S17400 H1025	316 SST Nitrided	Graphite
	556 ⁽²⁾	-46 to 427°C -50 to 800°F	CF8M or WCC	Chromium Carbide Coating	NOVEX ⁽⁷⁾	S31600	S17400 H1025	316 SST Nitrided	Graphite
NACE ⁽⁶⁾	558	-29 to 204°C -20 to 400°F	CF8M or WCC	None	Soft	PTFE	S17400 H1150M	PEEK	PTFE
	559	-46 to 232°C -50 to 450°F	CF8M or WCC	Chrome Plated	NOVEX ⁽⁷⁾	S31600	S17400 H1150M	PEEK	PTFE
	560 ⁽²⁾	-46 to 427°C -50 to 800°F	CF8M or WCC	Chromium Carbide Coating	NOVEX ⁽⁷⁾	S31600	S17400 H1150M	316 SST Nitrided	Graphite
	561 ⁽²⁾	-46 to 482°C -50 to 900°F	CF8M	Chromium Carbide Coating	NOVEX ⁽⁷⁾	S31600	N05500	316 SST Nitrided	Graphite
	562 ⁽²⁾	-46 to 538°C -50 to 1000°F	CF8M	Chromium Carbide Coating	NOVEX ⁽⁷⁾	S31600	S20910	316 SST Nitrided	Graphite
	563 ⁽²⁾	-46 to 538°C -50 to 1000°F	CF8M	Chromium Carbide Coating	NOVEX ⁽⁷⁾	S31600	N07718	316 SST Nitrided	Graphite
High-Temperature	564H ⁽³⁾	343 to 427°C 650 to 800°F	CF8M or WCC	Chromium Carbide Coating	NOVEX ⁽⁷⁾	S31600	S17400 H1025	316 SST Nitrided	Graphite
	565H ⁽³⁾	427 to 538°C 800 to 1000°F	CF8M	Chromium Carbide Coating	NOVEX ⁽⁷⁾	S31600	N07718	316 SST Nitrided	Graphite
	566H ⁽⁴⁾	538 to 704°C 1000 to 1300°F	CF8M	Chromium Carbide Coating	NOVEX ⁽⁷⁾	S31600	N07718	316 SST Nitrided	Graphite
Cryogenic	567C ⁽⁵⁾	-196 to 163°C -320 to 325°F	CF8M	Chrome Plated	NOVEX ⁽⁷⁾	S31600	S17400 H1150M	PTFE Composition	PTFE
	568C ⁽⁵⁾	-196 to 149°C -320 to 300°F	CF8M	Chrome Plated	Cryogenic	CTFE	S17400 H1150M	PTFE Composition	PTFE

1. Trim 550 is furnished as standard trim in all CL150/150, 150, and 300 A11 valves.
2. If operating temperature is above 343°C (650°F), see table 7 for available actuator configurations.
3. Trim includes 6-inch shaft extension.
4. Trim includes 12-inch shaft extension.
5. Trim includes Cryogenic shaft extension, see table 6 for extension length.
6. NACE MR0175-2002 and MR0103. For NACE MR0175-2003, or MR0175/ISO 15156 consult your Emerson Process Management sales office for material selection and pricing.
7. NPS 42 and 48 will have an S31600 metal seal ring in place of the S31600 NOVEX seal ring.

Table 6. Cryogenic Shaft Extension Lengths⁽¹⁾

CRYOGENIC EXTENSION LENGTH, INCH FOR VALVE BODY SIZE, NPS														
3	4	6	8	10	12	14	16	18	20	24	30	36	42	48
14-3/4	17-3/4	19-1/4	26-3/4	28-1/2	33-1/2	36	36	36	36	36	36	36	36	36

1. Extension length measured from center of valve body to bottom of packing flange.

Note

Trim will include the standard disc material included in the FS number selected. If the trim number indicates only a CF8M disc, the trim cannot be used with an FS number including a WCC disc.

Table 7. Valve/Actuator Combinations

TEMPERATURE RANGE	SELECTION GUIDELINES	
	1052, 1061, or 2052 ^(1, 2)	Bettis ⁽³⁾ , FieldQ™, 1035, or Hytork XL
-254 to -196°C (-425 to -320°F)	Valve with cryogenic extension and special trim materials ⁽⁴⁾ and standard actuator	Valve with cryogenic extension and special trim materials ⁽⁴⁾ and standard actuator
-196 to -46°C (-320 to -50°F)	Valve with cryogenic extension and trim and standard actuator	Valve with cryogenic extension and trim and standard actuator
-46 to 343°C (-50 to 650°F)	Valve (select appropriate trim) and standard actuator	Valve (select appropriate trim) and standard actuator
343 to 426°C (650 to 800°F)	Mounting positions 1 and 3: Valve (select appropriate trim) and standard actuator Mounting positions 2 and 4: Valve with 6-inch extension (select trim 514H or 554H) and standard actuator - ambient temperature may dictate the need for a high-temperature diaphragm	Valve (select appropriate trim) and actuator with high-temperature O-rings option or Valve with 6-inch extension (select trim 514H) and standard actuator
426 to 538°C (800 to 1000°F)	Mounting positions 1 and 3: Valve (select appropriate trim) and standard actuator Mounting positions 2 and 4: Valve with 6-inch extension (select trim 515H or 555H) and standard actuator - ambient temperature may dictate the need for a high-temperature diaphragm	Valve (select appropriate trim) and actuator with high-temperature O-rings option or Valve with 6-inch extension (select trim 515H) and standard actuator
538 to 704°C (1000 to 1300°F)	Valve with 12-inch extension (select trim 516H or 556H) and standard actuator	Valve with 12-inch extension (select trim 516H) and standard actuator
704 to 816°C (1300 to 1500°F)	Valve with 12-inch extension and special trim materials ⁽⁴⁾ and standard actuator	Valve with 12-inch extension and special trim materials ⁽⁴⁾ and standard actuator

1. Select splined shaft option.
 2. See figure 3 for actuator mounting positions.
 3. Select keyed shaft option when using Bettis "G" Series Actuator, NPS 6-12.
 4. Consult your Emerson Process Management sales office.

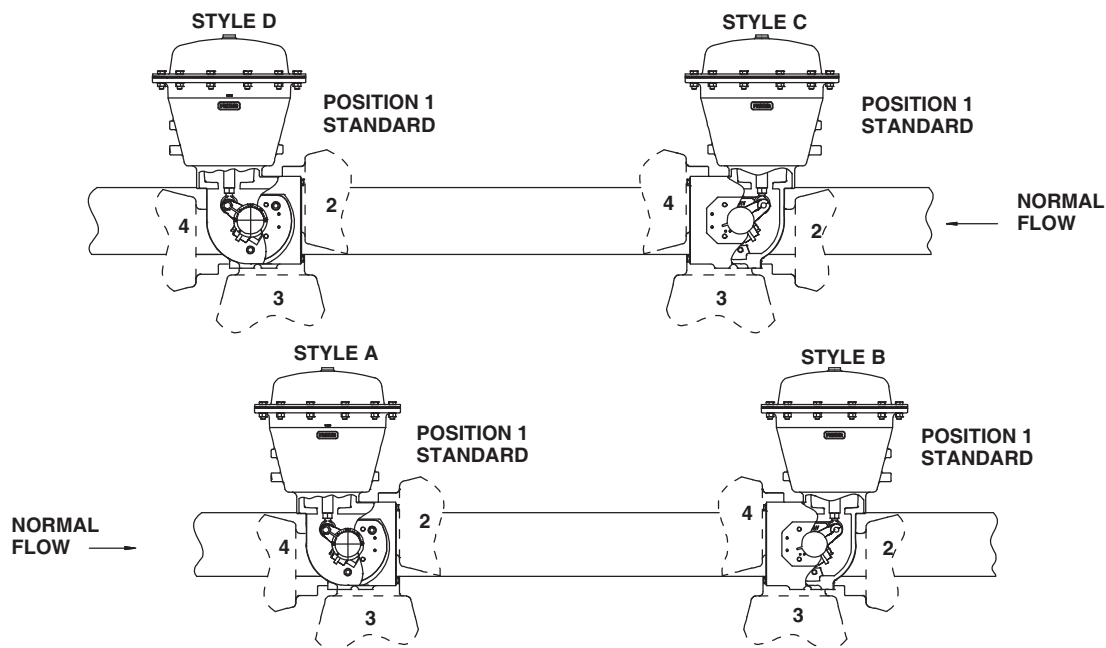

GE37285

Figure 3. Mounting Styles and Positions

Pressure Drops

Pressure drop limits of any given valve are based on valve body, and trim material limits. To find the appropriate pressure drop limitation, choose the desired valve size and temperature range. Then search table 8 for body limitations and tables 9, 10,

11, 12, 13, 14, 15, and 16 for trim limitations. Information on limits for S31254, CW2M, M35-1 and other alloy constructions can be obtained by contacting your Emerson Process Management sales office. The lowest number from the tables is the appropriate limit. **The tables for both trim and body limits must be consulted.**

Table 8. Maximum Allowable Shutoff Pressure Drops (Valve Ratings) Based on Carbon Steel and Stainless Steel Valve Types⁽¹⁾
The tables for both trim and body limits must be consulted.

TEMPERATURE RANGE	PRESSURE RANGE											
	CL150/150		CL150		CL300		CL600		CL900		CL1500	
	WCC	CF8M	WCC	CF8M	WCC	CF8M	WCC	CF8M	WCC	CF8M	WCC	CF8M
°C	Bar											
-254 to -29	---	10.3	---	19.0	---	49.6	---	99.3	---	148.9	---	248.2
-29 to 38	10.3	10.3	20	19.0	51.7	49.6	103.4	99.3	155.1	148.9	258.6	248.2
93	9.3	9.0	17.9	16.2	51.7	42.7	103.4	85.5	155.1	128.2	258.6	213.4
149	8.3	7.9	15.9	14.8	50.3	38.6	100.3	77.2	150.7	115.8	251.0	192.7
204	7.2	7.2	13.8	13.4	48.6	35.5	96.9	70.7	145.5	106.2	242.7	177.2
260	6.2	6.2	11.7	11.7	45.9	33.1	91.7	65.8	137.6	98.9	229.3	164.8
316	5.2	5.2	9.7	9.7	41.7	31.0	83.4	62.1	125.1	93.4	208.6	155.5
343	4.5	4.5	8.6	8.6	40.7	30.3	81.0	61.0	121.7	91.4	202.7	152.4
371	4.1	4.1	7.6	7.6	38.3	30.0	76.5	60.0	114.8	90.0	191.3	149.6
399	3.4	3.4	6.6	6.6	34.8	29.3	70.0	59.0	104.8	88.3	174.8	147.2
427	2.8	2.8	5.5	5.5	28.3	29.0	56.9	58.3	85.2	87.2	141.7	145.5
454	---	2.4	---	4.5	---	29.0	---	57.6	---	86.5	---	144.1
482	---	1.7	---	3.4	---	28.6	---	57.2	---	85.8	---	143.1
510	---	1.4	---	2.4	---	26.5	---	53.4	---	80.0	---	133.1
538	---	0.7	---	1.4	---	25.2	---	50.0	---	75.2	---	125.5
°F	Psi											
-450 to -20	---	150	---	275	---	720	---	1440	---	2160	---	3600
-20 to 100	150	150	290	275	750	720	1500	1440	2250	2160	3750	3600
200	135	130	260	235	750	620	1500	1240	2250	1860	3750	3095
300	120	115	230	215	730	560	1455	1120	2185	1680	3640	2795
400	105	105	200	195	705	515	1405	1025	2110	1540	3520	2570
500	90	90	170	170	665	480	1330	955	1995	1435	3325	2390
600	75	75	140	140	605	450	1210	900	1815	1355	3025	2255
650	65	65	125	125	590	440	1175	885	1765	1325	2940	2210
700	60	60	110	110	555	435	1110	870	1665	1305	2775	2170
750	50	50	95	95	505	425	1015	855	1520	1280	2535	2135
800	40	40	80	80	410	420	825	845	1235	1265	2055	2110
850	---	35	---	65	---	420	---	835	---	1255	---	2090
900	---	25	---	50	---	415	---	830	---	1245	---	2075
950	---	20	---	35	---	385	---	775	---	1160	---	1930
1000	---	10	---	20	---	365	---	725	---	1090	---	1820

1. For pressure/temperature rating of other materials, contact your Emerson Process Management sales office.

Table 9. Maximum Allowable Shutoff Pressure Drops⁽¹⁾

TRIM NUMBER	TEMPERATURE RANGE	PRESSURE RANGE											
		CL150/150				CL150				CL300			
		Valve Body Size, NPS				Valve Body Size, NPS				Valve Body Size, NPS			
		30	36	42	48	30	36	42	48	30	36	42	48
°C													
Bar													
550	-46 to 38	10.34	10.34	10.34	10.34	32.06	27.85	18.55	12.34	38.47	51.02	46.06	51.02
	38 to 149	10.34	10.34	10.34	10.34	27.58	27.58	18.55	12.34	27.58	27.58	27.58	27.58
	149 to 232	3.447	3.447	3.447	3.447	3.447	3.447	3.447	3.447	3.447	3.447	3.447	3.447
552, 553	-46 to 38	10.34	10.34	10.34	10.34	29.72	23.72	16.27	11.17	32.82	45.44	41.23	61.64
	38 to 149	10.34	10.34	10.34	10.34	25.72	23.72	16.27	11.17	32.82	45.44	41.23	61.64
	149 to 232	10.34	10.34	10.34	10.34	24.2	23.72	16.27	11.17	32.82	45.44	41.23	61.09
554	-46 to 38	10.34	8.136	10.34	4.964	21.24	16	9.584	5.792	26.48	35.78	31.37	48.06
	38 to 149	10.34	8.136	10.34	4.964	17.93	16	9.584	5.792	26.48	35.78	31.37	39.64
	149 to 232	10.34	8.136	10.34	4.964	16.75	16	9.584	5.792	20.68	20.68	20.68	20.68
555, 556	-46 to 38	10.34	10.34	10.34	7.722	22.75	16.62	11.45	7.653	22.75	32.47	29.51	44.33
	38 to 149	10.34	10.34	10.34	7.722	19.65	16.62	11.45	7.653	22.75	32.47	29.51	44.33
	149 to 232	10.34	10.34	10.34	7.722	18.48	16.62	11.45	7.653	22.75	32.47	29.51	44.33
	232 to 343	10.34	10.34	10.34	7.722	17.44	16.62	11.45	7.653	22.75	32.47	29.51	44.33
556	343 to 427	10.34	10.34	10.34	7.446	16.89	16.62	11.17	7.446	22.75	32.47	29.51	44.33
558	-46 to 38	10.34	10.34	10.34	10.34	20.55	25.03	18.55	12.34	38.47	46.88	40.27	49.23
	38 to 149	10.34	10.34	10.34	10.34	17.58	22.89	16.96	12.34	27.58	27.58	27.58	27.58
	149 to 232	3.447	3.447	3.447	3.447	3.447	3.447	3.447	3.447	3.447	3.447	3.447	3.447
559	-46 to 38	10.34	10.34	10.34	10.34	16.27	22.55	16.27	11.17	32.82	41.44	39.99	46.4
	38 to 149	10.34	10.34	10.34	10.34	13.93	19.51	16.27	11.17	32.82	36.06	34.89	40.54
	149 to 232	10.34	10.34	10.34	10.34	13.03	18.41	16.2	11.17	32.82	34.13	32.96	38.4
560	-46 to 38	10.34	10.34	10.34	7.722	12.41	16.96	11.45	7.653	22.75	31.03	29.51	34.34
	38 to 427	7.998	9.791	10.34	7.722	9.032	12.69	11.45	7.653	22.75	23.44	22.61	26.13
561, 563	-46 to 482	10.34	10.34	10.34	7.722	14.41	16.96	11.45	7.653	22.75	32.54	29.51	39.16
562	-46 to 38	9.584	10.34	9.997	7.722	10.76	11.58	10.48	6.964	20.82	21.51	20.75	24.06
	38 to 232	6.343	8.618	7.86	5.723	7.239	8.067	7.033	4.551	14.13	15.38	14.89	17.37
	232 to 593	4.482	6.55	6.412	4.068	5.24	5.998	5.102	3.172	10.27	11.86	11.45	13.51
564H	343 to 427	10.34	10.34	10.34	7.722	16.89	16.96	11.45	7.653	22.75	32.54	29.51	44.33
565H	427 to 482	10.34	10.34	10.34	7.722	24.55	16.96	11.45	7.653	22.75	32.54	29.51	44.33
566H	538 to 649	10.34	10.2	10.34	7.722	19.03	16.96	11.45	7.653	22.75	32.54	29.51	40.54
	649 to 704	4.344	4.344	4.826	4.826	8.549	9.377	6.274	6.343	19.51	18	14.55	18.06
567C,	-196 to -46	10.34	10.34	10.34	10.34	26.34	28.89	20.82	14.34	41.78	55.23	46.61	56.95
568C	-46 to 149	10.34	10.34	10.34	10.34	17.24	22.89	16.89	14.34	41.78	43.99	36.89	45.23

1. Consult your Emerson Process Management sales office if higher pressure drops are required.

Product Bulletin

21.1:A11
April 2010

A11 Valve

Table 10. Maximum Allowable Shutoff Pressure Drops⁽¹⁾

TRIM NUMBER	TEMPERATURE RANGE	PRESSURE RANGE											
		CL150/150				CL150				CL300			
		Valve Body Size, NPS				Valve Body Size, NPS				Valve Body Size, NPS			
		30	36	42	48	30	36	42	48	30	36	42	48
°F		Psi											
550	-50 to 100	150	150	150	150	465	404	269	179	558	740	668	740
	100 to 300	150	150	150	150	400	400	269	179	400	400	400	400
	300 to 450	50	50	50	50	50	50	50	50	50	50	50	50
552, 553	-50 to 100	150	150	150	150	431	344	236	162	476	659	598	894
	100 to 300	150	150	150	150	373	344	236	162	476	659	598	894
	300 to 450	150	150	150	150	351	344	236	162	476	659	598	886
554	-50 to 100	150	118	150	72	308	232	139	84	384	519	455	697
	100 to 300	150	118	150	72	260	232	139	84	384	519	455	575
	300 to 450	150	118	150	72	243	232	139	84	300	300	300	300
555, 556	-50 to 100	150	150	150	112	330	241	166	111	330	471	428	643
	100 to 300	150	150	150	112	285	241	166	111	330	471	428	643
	300 to 450	150	150	150	112	268	241	166	111	330	471	428	643
	450 to 650	150	150	150	112	253	241	166	111	330	471	428	643
556	650 to 800	150	150	150	108	245	241	162	108	330	471	428	643
558	-50 to 100	150	150	150	150	298	363	269	179	558	680	584	714
	100 to 300	150	150	150	150	255	332	246	179	400	400	400	400
	300 to 450	50	50	50	50	50	50	50	50	50	50	50	50
559	-50 to 100	150	150	150	150	236	327	236	162	476	601	580	673
	100 to 300	150	150	150	150	202	283	236	162	476	523	506	588
	300 to 450	150	150	150	150	189	267	235	162	476	495	478	557
560	-50 to 100	150	150	150	112	180	246	166	111	330	450	428	498
	100 to 800	116	142	150	112	131	184	166	111	330	340	328	379
561, 563	-50 to 900	150	150	150	112	209	246	166	111	330	472	428	568
562	-50 to 100	139	150	145	112	156	168	152	101	302	312	301	349
	100 to 450	92	125	114	83	105	117	102	66	205	223	216	252
	450 to 1100	65	95	93	59	76	87	74	46	149	172	166	196
564H	650 to 800	150	150	150	112	245	246	166	111	330	472	428	643
565H	800 to 1000	150	150	150	112	356	246	166	111	330	472	428	643
566H	1000 to 1200	150	148	150	112	276	246	166	111	330	472	428	588
	1200 to 1300	63	63	70	70	124	136	91	92	283	261	211	262
567C, 568C	-320 to -50	150	150	150	150	382	419	302	208	606	801	676	826
	-50 to 300	150	150	150	150	250	332	245	208	606	638	535	656

1. Consult your Emerson Process Management sales office if higher pressure drops are required.

Table 11. Maximum Allowable Shutoff Pressure Drops, CL600⁽¹⁾

TRIM NUMBER	TEMP RANGE	NPS 3	NPS 4	NPS 6	NPS 8	NPS 10	NPS 12	NPS 14	NPS 16	NPS 18	NPS 20	NPS 24
	°C											
500, 501	-46 to 38	98.9	103.1	103.4	103.4	99.1	100.3	103.4	103.4	103.4	103.4	60.9
	38 to 93	75.8	75.8	75.8	75.8	75.8	75.8	75.8	75.8	75.8	75.8	60.9
	93 to 121	41.4	41.4	41.4	41.4	41.4	41.4	41.4	41.4	41.4	41.4	41.4
	121 to 149	6.9	6.9	6.9	6.9	6.9	6.9	6.9	6.9	6.9	6.9	6.9
502, 503	-46 to 38	73.8	100.4	110.2	108.2	98.0	107.3	123.0	131.1	129.1	94.8	55.2
	38 to 232	50.7	87.6	96.5	93.3	86.9	84.1	109.3	115.8	118.2	94.8	55.2
504	-46 to 38	48.2	100.1	103.4	103.4	98.1	101.8	103.4	103.4	103.4	84.7	46.2
	38 to 93	35.3	94.3	96.5	96.5	93.0	92.6	96.5	96.5	96.5	84.7	46.2
	93 to 121	31.1	62.1	62.1	62.1	62.1	62.1	62.1	62.1	62.1	62.1	46.2
	121 to 149	20.7	20.7	20.7	20.7	20.7	20.7	20.7	20.7	20.7	20.7	20.7
505, 506	-46 to 38	49.4	98.4	108.5	75.5	81.6	59.5	114.9	107.1	93.3	67.2	38.1
	38 to 343	26.0	82.0	91.0	75.5	81.6	59.5	101.8	83.2	93.3	67.2	38.1
506	343 to 427	23.4	80.1	88.9	75.5	80.5	59.5	98.5	80.5	93.3	67.2	38.1
508	-46 to 38	62.1	70.5	76.3	75.7	69.6	70.3	87.7	90.3	93.7	103.4	60.9
	38 to 93	55.4	66.4	71.8	71.4	65.8	64.2	75.8	75.8	75.8	75.8	60.9
	93 to 121	41.4	41.4	41.4	41.4	41.4	41.4	41.4	41.4	41.4	41.4	41.4
	121 to 149	6.9	6.9	6.9	6.9	6.9	6.9	6.9	6.9	6.9	6.9	6.9
509	-46 to 38	17.2	66.4	74.0	57.2	68.3	57.0	86.8	79.3	93.2	94.8	55.2
	38 to 232	3.7	56.5	63.5	42.5	59.7	44.8	76.5	64.5	81.7	80.3	53.9
510	-46 to 38	3.5	56.7	65.7	38.0	66.5	38.6	73.5	60.3	85.4	67.2	38.1
	38 to 232	0.0	41.3	49.8	26.5	57.8	29.4	59.6	49.0	70.1	60.6	38.1
	232 to 427	0.0	33.2	43.7	22.2	54.4	25.8	44.2	44.6	64.2	55.5	37.2
511	-46 to 38	22.6	79.6	88.4	57.8	80.0	54.7	97.6	79.8	93.4	67.2	38.1
	38 to 427	18.4	76.3	84.9	53.4	77.2	51.2	92.3	75.4	93.4	67.2	38.1
	427 to 482	12.4	71.4	78.5	47.2	73.0	46.2	84.7	69.4	93.4	67.2	38.1
512	-46 to 38	18.8	76.7	85.3	53.8	77.4	32.2	63.9	52.4	58.9	50.9	34.1
	38 to 343	0.0	37.7	49.1	26.1	57.5	16.1	39.8	32.8	37.6	32.6	21.0
	343 to 593	0.0	25.6	38.5	18.4	46.7	11.7	33.1	27.4	31.7	27.6	17.2
513	-46 to 38	74.7	114.2	125.5	75.5	81.6	59.5	115.0	133.0	93.4	67.2	38.1
	38 to 482	58.5	104.2	114.7	75.5	81.6	59.5	115.0	116.4	93.4	67.2	38.1
	482 to 593	56.2	84.1	89.9	75.5	81.0	59.5	101.4	106.8	93.4	67.2	38.1
514H	343 to 427	23.4	80.1	88.9	58.5	80.5	55.4	98.5	80.5	93.3	67.2	38.1
515H	427 to 482	59.2	104.7	115.2	75.5	81.6	59.5	115.0	117.1	93.4	67.2	38.1
516H	482 to 649	54.1	58.2	61.6	61.4	57.2	59.5	72.3	74.9	75.8	67.2	38.1
	649 to 704	23.4	23.2	23.9	24.6	24.1	27.4	31.2	31.1	31.0	35.4	35.2
517C	-196 to 163	Consult your Emerson Process Management sales office.										
518C	-196 to -129	88.4	92.3	100.2	98.7	89.9	104.5	112.5	119.2	121.3	135.1	78.3
	-129 to -46	79.6	83.2	90.3	89.1	81.6	94.8	102.3	108.1	110.0	122.6	78.3
	-46 to 38	61.5	70.7	76.7	76.3	70.3	77.6	88.6	93.1	94.5	105.6	78.3
	38 to 149	51.0	64.1	69.5	69.4	64.3	66.7	81.2	85.1	86.3	96.5	78.3

1. Consult your Emerson Process Management sales office if higher pressure drops are required.

Product Bulletin

21.1:A11
April 2010

A11 Valve

Table 12. Maximum Allowable Shutoff Pressure Drops, CL600⁽¹⁾

TRIM NUMBER	TEMP RANGE	NPS 3	NPS 4	NPS 6	NPS 8	NPS 10	NPS 12	NPS 14	NPS 16	NPS 18	NPS 20	NPS 24
	°F											
500, 501	-50 to 100	1435	1495	1500	1500	1437	1455	1500	1500	1500	1500	883
	100 to 200	1100	1100	1100	1100	1100	1100	1100	1100	1100	1100	883
	200 to 250	600	600	600	600	600	600	600	600	600	600	600
	250 to 300	100	100	100	100	100	100	100	100	100	100	100
502, 503	-50 to 100	1071	1456	1598	1569	1422	1556	1784	1901	1873	1375	800
	100 to 450	735	1270	1400	1353	1260	1220	1585	1680	1715	1375	800
504	-50 to 100	699	1453	1500	1500	1422	1477	1500	1500	1500	1229	670
	100 to 200	512	1368	1400	1400	1349	1344	1400	1400	1400	1229	670
	200 to 250	452	900	900	900	900	900	900	900	900	900	670
	250 to 300	300	300	300	300	300	300	300	300	300	300	300
505, 506	-50 to 100	716	1427	1574	1095	1184	863	1667	1554	1353	974	553
	100 to 650	377	1190	1320	1095	1184	863	1477	1206	1353	974	553
506	650 to 800	339	1162	1290	1095	1167	863	1429	1168	1353	974	553
508	-50 to 100	901	1023	1107	1098	1009	1020	1272	1309	1359	1500	883
	100 to 200	804	963	1042	1036	955	931	1100	1100	1100	1100	883
	200 to 250	600	600	600	600	600	600	600	600	600	600	600
	250 to 300	100	100	100	100	100	100	100	100	100	100	100
509	-50 to 100	250	963	1074	829	990	826	1259	1150	1352	1375	800
	100 to 450	53	820	921	616	866	650	1109	935	1185	1165	782
510	-50 to 100	51	822	953	551	965	560	1066	874	1238	974	553
	100 to 450	0	599	722	385	839	426	865	710	1016	879	553
	450 to 800	0	481	634	322	789	374	641	647	931	805	539
511	-50 to 100	328	1154	1282	838	1160	794	1416	1157	1354	974	553
	100 to 800	267	1107	1232	775	1119	742	1339	1094	1354	974	553
	800 to 900	180	1035	1139	685	1059	670	1229	1006	1354	974	553
512	-50 to 100	273	1112	1237	781	1123	467	927	760	854	738	494
	100 to 650	0	547	712	378	834	233	577	476	546	473	304
	650 to 1100	0	371	558	267	678	169	480	398	460	400	249
513	-50 to 100	1083	1656	1820	1095	1184	863	1668	1929	1354	974	553
	100 to 900	848	1511	1664	1095	1184	863	1668	1688	1354	974	553
	900 to 1100	815	1220	1304	1095	1175	863	1470	1549	1354	974	553
514H	650 to 800	339	1162	1290	849	1167	803	1429	1168	1353	974	553
515H	800 to 1000	858	1518	1671	1095	1184	863	1668	1698	1354	974	553
516H	1000 to 1200	784	844	893	890	830	863	1048	1087	1099	974	553
	1200 to 1300	339	337	347	357	350	397	453	451	450	513	511
517C	-320 to 325	Consult your Emerson Process Management sales office.										
518C	-320 to -200	1282	1339	1454	1431	1304	1516	1631	1729	1760	1959	1135
	-200 to -50	1155	1206	1309	1293	1184	1375	1484	1568	1595	1778	1135
	-50 to 100	892	1025	1113	1106	1020	1126	1285	1350	1371	1532	1135
	100 to 300	739	929	1008	1006	933	967	1178	1234	1251	1400	1135

1. Consult your Emerson Process Management sales office if higher pressure drops are required.

Table 13. Maximum Allowable Shutoff Pressure Drops, CL900^(1, 2)

TRIM NUMBER	TEMP RANGE	NPS 6	NPS 8	NPS 10	NPS 12	NPS 14	NPS 16	NPS 18	NPS 20	NPS 24
	°C									
500	-46 to 38	103.4	103.4	103.4	103.4	103.4	103.4	103.4	103.4	103.4
	38 to 93	75.8	75.8	75.8	75.8	75.8	75.8	75.8	75.8	75.8
	93 to 121	41.4	41.4	41.4	41.4	41.4	41.4	41.4	41.4	41.4
	121 to 149	6.9	6.9	6.9	6.9	6.9	6.9	6.9	6.9	6.9
502	-46 to 38	100.0	155.1	110.7	155.1	146.6	154.2	151.9	120.0	128.7
	38 to 149	84.6	146.2	110.7	150.7	146.5	139.3	139.1	120.0	128.6
	149 to 232	78.8	140.4	110.7	141.7	141.7	131.5	134.1	120.0	128.7
504	-46 to 38	103.4	103.4	103.4	103.4	103.4	103.4	103.4	91.0	92.8
	38 to 93	96.5	96.5	96.5	96.5	96.5	96.5	96.5	91.0	92.8
	93 to 121	62.1	62.1	62.1	62.1	62.1	62.1	62.1	62.1	62.1
505, 506	-46 to 38	81.1	122.2	78.5	131.3	104.1	119.8	118.7	82.5	89.9
	38 to 149	67.6	122.2	78.5	131.3	104.1	103.4	118.7	82.5	89.9
	149 to 232	62.6	122.2	78.5	131.3	104.1	97.4	118.7	82.5	89.9
	232 to 343	58.1	121.3	78.5	121.3	104.1	91.8	118.7	82.5	89.9
506	343 to 427	55.5	105.1	78.5	105.1	104.1	88.7	105.1	82.5	89.9
508	-46 to 38	80.9	103.4	103.4	103.4	103.4	103.4	103.4	103.4	103.4
	38 to 93	75.8	75.8	75.8	75.8	75.8	75.8	75.8	75.8	75.8
	93 to 121	41.4	41.4	41.4	41.4	41.4	41.4	41.4	41.4	41.4
	121 to 149	6.9	6.9	6.9	6.9	6.9	6.9	6.9	6.9	6.9
509	-46 to 38	48.1	107.2	102.7	128.2	113.3	90.0	105.6	114.3	105.1
	38 to 149	39.0	96.4	93.4	115.9	103.1	77.8	96.0	99.4	96.0
	149 to 232	35.6	92.3	89.7	111.1	99.1	73.2	92.4	93.8	92.5
510	-46 to 38	36.0	103.7	78.5	125.1	104.1	64.9	102.9	82.5	89.9
	38 to 149	28.1	92.9	78.5	112.7	90.1	55.4	93.4	71.4	89.9
	149 to 232	25.2	88.7	78.5	108.0	84.7	51.8	89.6	67.2	89.9
	232 to 343	22.5	84.8	78.5	103.6	79.8	48.5	86.3	63.3	86.6
	343 to 427	21.0	82.6	77.6	101.1	76.9	46.7	84.3	61.1	84.7
511	-46 to 38	54.8	110.3	78.5	131.3	86.2	68.9	65.5	82.5	75.8
	38 to 149	52.7	85.5	78.5	120.3	66.8	53.4	80.8	72.2	58.8
	149 to 232	50.7	76.1	71.4	107.0	59.4	47.6	45.2	64.2	52.3
	232 to 343	50.7	67.8	63.6	95.4	53.0	42.4	40.3	57.2	46.6
	343 to 427	50.7	64.7	60.6	90.9	50.5	40.4	38.4	54.6	44.5
	427 to 482	44.8	63.5	59.5	89.3	49.6	39.7	37.7	53.6	43.6
512	-46 to 38	51.0	110.3	78.5	113.3	86.2	55.8	65.5	55.6	75.8
	38 to 149	35.4	85.6	78.5	94.8	66.8	42.2	50.8	42.5	58.8
	149 to 232	29.7	76.1	71.4	87.8	59.4	37.3	45.2	37.9	52.3
	232 to 343	24.7	67.8	63.6	81.2	53.0	32.9	40.3	33.6	46.6
	343 to 427	21.9	64.7	60.7	77.4	50.5	30.4	38.4	31.2	44.5
	427 to 482	20.2	63.5	59.5	75.2	49.6	29.0	37.7	29.9	43.6
	482 to 538	17.4	32.7	30.6	45.9	25.5	20.4	19.4	27.6	22.5
513	-46 to 38	105.6	110.3	78.5	131.3	86.2	68.9	65.5	82.5	75.8
	38 to 149	96.3	85.6	80.2	120.3	66.8	53.4	50.8	72.2	58.8
	149 to 232	85.6	76.1	71.4	107.0	59.4	47.6	45.2	64.2	52.3
	232 to 343	76.3	67.8	63.6	95.4	53.0	42.4	40.3	57.2	46.6
	343 to 427	72.7	64.7	60.6	90.9	50.5	40.4	38.4	54.6	44.5
	427 to 482	71.4	63.5	59.5	89.3	49.6	39.7	37.7	53.6	43.6
514H	343 to 427	55.5	105.1	78.5	105.1	104.1	88.7	105.1	82.5	89.9
515H	427 to 482	70.4	62.5	58.7	88.0	48.9	39.1	37.2	52.8	43.0
516H	482 to 649	22.8	20.3	19.0	28.5	15.8	12.6	12.0	17.1	13.9
	649 to 704	14.4	12.8	12.0	18.0	10.0	8.0	7.6	10.8	8.8
517C	-196 to 163	Consult your Emerson Process Management sales office.								

1. Consult your Emerson Process Management sales office if higher pressure drops are required.
2. Consult Fisher bulletin 59.3:042 (D102093X012) for packing selection guidelines regarding pressure/temperature limits.

Product Bulletin

21.1:A11
April 2010

A11 Valve

Table 14. Maximum Allowable Shutoff Pressure Drops, CL900^(1, 2)

TRIM NUMBER	TEMP RANGE	NPS 6	NPS 8	NPS 10	NPS 12	NPS 14	NPS 16	NPS 18	NPS 20	NPS 24
	°F									
500	-50 to 100	1500	1500	1500	1500	1500	1500	1500	1500	1500
	100 to 200	1100	1100	1100	1100	1100	1100	1100	1100	1100
	200 to 250	600	600	600	600	600	600	600	600	600
	250 to 300	100	100	100	100	100	100	100	100	100
502	-50 to 100	1451	2250	1606	2250	2126	2237	2203	1741	1866
	100 to 300	1227	2120	1606	2185	2125	2020	2017	1741	1865
	300 to 450	1143	2036	1606	2055	2055	1907	1945	1741	1866
504	-50 to 100	1500	1500	1500	1500	1500	1500	1500	1320	1346
	100 to 200	1400	1400	1400	1400	1400	1400	1400	1320	1346
	200 to 250	900	900	900	900	900	900	900	900	900
	250 to 300	300	300	300	300	300	300	300	300	300
505, 506	-50 to 100	1176	1773	1138	1905	1510	1737	1721	1197	1304
	100 to 300	980	1773	1138	1905	1510	1500	1721	1197	1304
	300 to 450	908	1773	1138	1905	1510	1412	1721	1197	1304
	450 to 650	842	1760	1138	1760	1510	1332	1721	1197	1304
506	650 to 800	805	1525	1138	1525	1510	1286	1525	1197	1304
508	-50 to 100	1174	1500	1500	1500	1500	1500	1500	1500	1500
	100 to 200	1100	1100	1100	1100	1100	1100	1100	1100	1100
	200 to 250	600	600	600	600	600	600	600	600	600
	250 to 300	100	100	100	100	100	100	100	100	100
509	-50 to 100	698	1555	1490	1859	1644	1306	1531	1658	1525
	100 to 300	566	1398	1354	1681	1495	1128	1393	1441	1393
	300 to 450	517	1338	1301	1612	1437	1062	1340	1360	1341
510	-50 to 100	522	1504	1138	1814	1510	942	1492	1197	1304
	100 to 300	408	1347	1138	1635	1307	803	1354	1036	1304
	300 to 450	366	1286	1138	1567	1228	751	1300	974	1304
	450 to 650	327	1230	1138	1503	1157	704	1251	918	1256
	650 to 800	305	1198	1126	1467	1116	678	1222	886	1229
511	-50 to 100	795	1600	1138	1905	1250	1000	950	1197	1100
	100 to 300	764	1240	1138	1745	969	775	737	1047	853
	300 to 450	735	1104	1035	1552	862	690	655	931	759
	450 to 650	735	984	922	1384	769	615	584	830	676
	650 to 800	735	938	879	1319	733	586	557	792	645
	800 to 900	650	921	863	1295	719	576	547	777	633
512	-50 to 100	740	1600	1138	1644	1250	810	950	806	1100
	100 to 300	513	1241	1138	1375	969	612	737	617	853
	300 to 450	431	1104	1035	1273	862	541	655	549	759
	450 to 650	358	984	922	1177	769	477	584	488	676
	650 to 800	317	938	880	1123	733	441	557	453	645
	800 to 900	293	921	863	1091	719	421	547	433	633
	900 to 1100	253	474	444	666	370	296	281	400	326
513	-50 to 100	1531	1600	1138	1905	1250	1000	950	1197	1100
	100 to 300	1396	1241	1163	1745	969	775	737	1047	853
	300 to 450	1242	1104	1035	1552	862	690	655	931	759
	450 to 650	1107	984	922	1384	769	615	584	830	676
	650 to 800	1055	938	879	1319	733	586	557	792	645
	800 to 900	1036	921	863	1295	719	576	547	777	633
	900 to 1100	533	474	444	666	370	296	281	400	326
514H	650 to 800	805	1525	1138	1525	1510	1286	1525	1197	1304
515H	800 to 1000	1021	907	851	1276	709	567	539	766	624
516H	1000 to 1200	330	294	275	413	229	183	174	248	202
	1200 to 1300	209	185	174	261	145	116	110	156	128
517C	-320 to 325	Consult your Emerson Process Management sales office.								

1. Consult your Emerson Process Management sales office if higher pressure drops are required.
2. Consult Fisher bulletin 59.3:042 (D102093X012) for packing selection guidelines regarding pressure/temperature limits.

Table 15. Maximum Allowable Shutoff Pressure Drops, CL1500^(1, 2)

TRIM NUMBER	TEMP RANGE	NPS 10	NPS 12	NPS 14	NPS 16	NPS 18	NPS 20
	°C						
		Bar					
500	-46 to 38	103.4	103.4	103.4	103.4	103.4	103.4
	38 to 93	75.8	75.8	75.8	75.8	75.8	75.8
	93 to 121	41.4	41.4	41.4	41.4	41.4	41.4
	121 to 149	6.9	6.9	6.9	6.9	6.9	6.9
502	-46 to 38	179.0	248.1	169.4	201.5	249.7	243.0
	38 to 149	155.0	226.5	169.5	201.5	228.1	222.1
	149 to 232	146.1	218.2	169.5	201.5	219.7	214.0
504	-46 to 38	103.4	103.4	103.4	103.4	103.4	103.4
	38 to 93	96.5	96.5	96.5	96.5	96.5	96.5
	93 to 121	62.1	62.1	62.1	62.1	62.1	62.1
	121 to 149	20.7	20.7	20.7	20.7	20.7	20.7
505, 506	-46 to 38	133.5	186.2	116.5	139.5	235.4	174.7
	38 to 149	114.2	186.2	116.5	139.5	224.8	174.7
	149 to 232	107.1	186.2	116.5	139.5	216.3	174.7
	232 to 343	100.6	186.2	116.5	139.5	202.2	174.7
506	343 to 427	96.9	175.1	116.5	139.5	175.1	174.7
508	-46 to 38	103.4	103.4	103.4	103.4	103.4	103.4
	38 to 93	75.8	75.8	75.8	75.8	75.8	75.8
	93 to 121	41.4	41.4	41.4	41.4	41.4	41.4
	121 to 149	6.9	6.9	6.9	6.9	6.9	6.9
509	-46 to 38	98.7	169.8	131.4	179.3	171.3	167.3
	38 to 149	84.7	153.9	113.8	162.6	155.4	151.9
	149 to 232	79.4	147.8	107.3	156.2	149.2	146.0
510	-46 to 38	69.0	165.5	94.8	139.6	167.7	163.8
	38 to 149	57.8	149.5	81.0	139.6	151.8	148.4
	149 to 232	53.6	143.5	75.9	139.6	145.6	142.5
	232 to 343	49.8	136.3	71.3	139.6	140.0	137.0
	343 to 427	47.6	131.7	68.7	139.6	136.7	133.8
511	-46 to 38	95.9	124.1	116.5	137.9	117.2	131.0
	38 to 149	92.9	96.3	117.6	106.9	90.9	101.6
	149 to 232	90.0	85.6	104.7	95.1	80.9	90.4
	232 to 343	84.8	76.3	93.3	84.8	72.1	80.5
	343 to 427	80.9	72.7	88.9	80.9	68.7	76.8
	427 to 482	79.4	71.4	87.3	79.4	67.4	75.4
512	-46 to 38	58.3	124.1	62.1	127.8	117.2	125.8
	38 to 149	42.3	96.3	46.4	97.4	90.9	101.6
	149 to 232	36.6	85.6	40.8	86.7	80.9	90.4
	232 to 343	31.4	76.3	35.7	76.8	72.1	80.5
	343 to 427	28.5	72.7	32.9	71.3	68.7	76.8
	427 to 482	26.9	71.4	31.2	68.2	67.4	75.4
	482 to 538	24.1	36.7	28.5	40.8	34.7	38.8
513	-46 to 38	137.9	124.1	116.5	137.9	117.2	131.0
	38 to 149	106.9	96.3	116.5	106.9	90.9	101.6
	149 to 232	95.1	85.6	104.7	95.1	80.9	90.4
	232 to 343	84.8	76.3	93.3	84.8	72.1	80.5
	343 to 427	80.9	72.7	88.9	80.9	68.7	76.8
	427 to 482	79.4	71.4	87.3	79.4	67.4	75.4
	482 to 538	40.8	36.7	45.0	40.8	34.7	38.8
514H	343 to 427	96.9	175.1	116.5	139.5	175.1	174.8
515H	427 to 482	78.2	70.4	86.0	78.2	66.5	74.3
516H	482 to 649	25.3	22.8	27.9	25.3	21.5	24.1
	649 to 704	16.0	14.4	17.6	16.0	13.6	15.2
517C	-196 to 163	Consult your Emerson Process Management sales office.					

1. Consult your Emerson Process Management sales office if higher pressure drops are required.
2. Consult Fisher bulletin 59.3:042 (D102093X012) for packing selection guidelines regarding pressure/temperature limits.

Product Bulletin

21.1:A11
April 2010

A11 Valve

Table 16. Maximum Allowable Shutoff Pressure Drops, CL1500^(1, 2)

TRIM NUMBER	TEMP RANGE	NPS 10	NPS 12	NPS 14	NPS 16	NPS 18	NPS 20
	°F						
500	-50 to 100	1500	1500	1500	1500	1500	1500
	100 to 200	1100	1100	1100	1100	1100	1100
	200 to 250	600	600	600	600	600	600
	250 to 300	100	100	100	100	100	100
502	-50 to 100	2596	3599	2457	2922	3622	3525
	100 to 300	2248	3285	2458	2922	3309	3221
	300 to 450	2119	3164	2458	2922	3187	3104
504	-50 to 100	1500	1500	1500	1500	1500	1500
	100 to 200	1400	1400	1400	1400	1400	1400
	200 to 250	900	900	900	900	900	900
	250 to 300	300	300	300	300	300	300
505, 506	-50 to 100	1936	2700	1689	2024	3414	2534
	100 to 300	1657	2700	1689	2024	3260	2534
	300 to 450	1553	2700	1689	2024	3137	2534
	450 to 650	1459	2700	1689	2024	2933	2534
506	650 to 800	1405	2540	1689	2024	2540	2534
508	-50 to 100	1500	1500	1500	1500	1500	1500
	100 to 200	1100	1100	1100	1100	1100	1100
	200 to 250	600	600	600	600	600	600
	250 to 300	100	100	100	100	100	100
509	-50 to 100	1431	2463	1906	2600	2484	2426
	100 to 300	1228	2232	1651	2358	2254	2203
	300 to 450	1152	2144	1556	2265	2164	2118
510	-50 to 100	1001	2401	1375	2025	2432	2376
	100 to 300	838	2169	1175	2025	2201	2153
	300 to 450	778	2081	1101	2025	2112	2067
	450 to 650	722	1977	1034	2025	2030	1987
	650 to 800	691	1910	996	2025	1982	1941
511	-50 to 100	1391	1800	1689	2000	1700	1900
	100 to 300	1348	1396	1706	1551	1318	1473
	300 to 450	1305	1242	1518	1380	1173	1311
	450 to 650	1230	1107	1353	1230	1045	1168
	650 to 800	1173	1055	1290	1173	997	1114
	800 to 900	1151	1036	1266	1151	978	1094
512	-50 to 100	846	1800	900	1853	1700	1824
	100 to 300	614	1396	673	1413	1318	1473
	300 to 450	531	1242	592	1257	1173	1311
	450 to 650	456	1107	518	1114	1045	1168
	650 to 800	414	1055	477	1034	997	1114
	800 to 900	390	1036	453	989	978	1094
	900 to 1100	349	533	413	592	504	563
513	-50 to 100	2000	1800	1689	2000	1700	1900
	100 to 300	1551	1396	1689	1551	1318	1473
	300 to 450	1380	1242	1518	1380	1173	1311
	450 to 650	1230	1107	1353	1230	1045	1168
	650 to 800	1173	1055	1290	1173	997	1114
	800 to 900	1151	1036	1266	1151	978	1094
	900 to 1100	592	533	652	592	504	563
514H	650 to 800	1406	2540	1689	2024	2540	2535
515H	800 to 1000	1134	1021	1248	1134	964	1077
516H	1000 to 1200	367	330	404	367	312	349
	1200 to 1300	232	209	255	232	197	220
517C	-320 to 325	Consult your Emerson Process Management sales office.					

1. Consult your Emerson Process Management sales office if higher pressure drops are required.
2. Consult Fisher bulletin 59.3:042 (D102093X012) for packing selection guidelines regarding pressure/temperature limits.

A11 Valve

Table 17. Dimensions and Weights Wafer Style and Single Flange CL150/150

VALVE SIZE, NPS	A		B	C	D	E	F	H	J	K	L	M ⁽¹⁾	R	KEY SQ SIZE	APPROX WEIGHT
	Wafer	Single Flange													
mm															
30	864	994	121	559	516	295	95.25	337	See Thread Info Below	76.2	See Thread Info Below	744	57.2	12.7	528
36	1029	1178	149	683	613	295	95.25	337		76.2		888	57.2	12.7	806
42	1207	1356	210	762	695	314	114.3	337		76.2		1032	69.9	15.9	1302
48	1364	1524	229	889	826	314	114.3	305		152		1180	69.9	15.9	1904
Inches															
30	34.00	39.12	4.75	22.00	20.31	11.62	3.75	13.25	1-1/4-8	3.00	7/8-9	29.30	2.25	1/2	1164
36	40.50	46.38	5.88	26.88	24.12	11.62	3.75	13.25	1-1/2-8	3.00	7/8-9	34.96	2.25	1/2	1778
42	47.50	53.38	8.25	30.00	27.38	12.38	4.5	13.25	1-1/2-8	3.00	7/8-9	40.64	2.75	5/8	2871
48	53.69	60.00	9.00	35.00	32.50	12.38	4.5	12.00	1-1/2-8	6.00	1-1/4-7	46.47	2.75	5/8	4198

1. M dimension is disc chordal swing diameter.

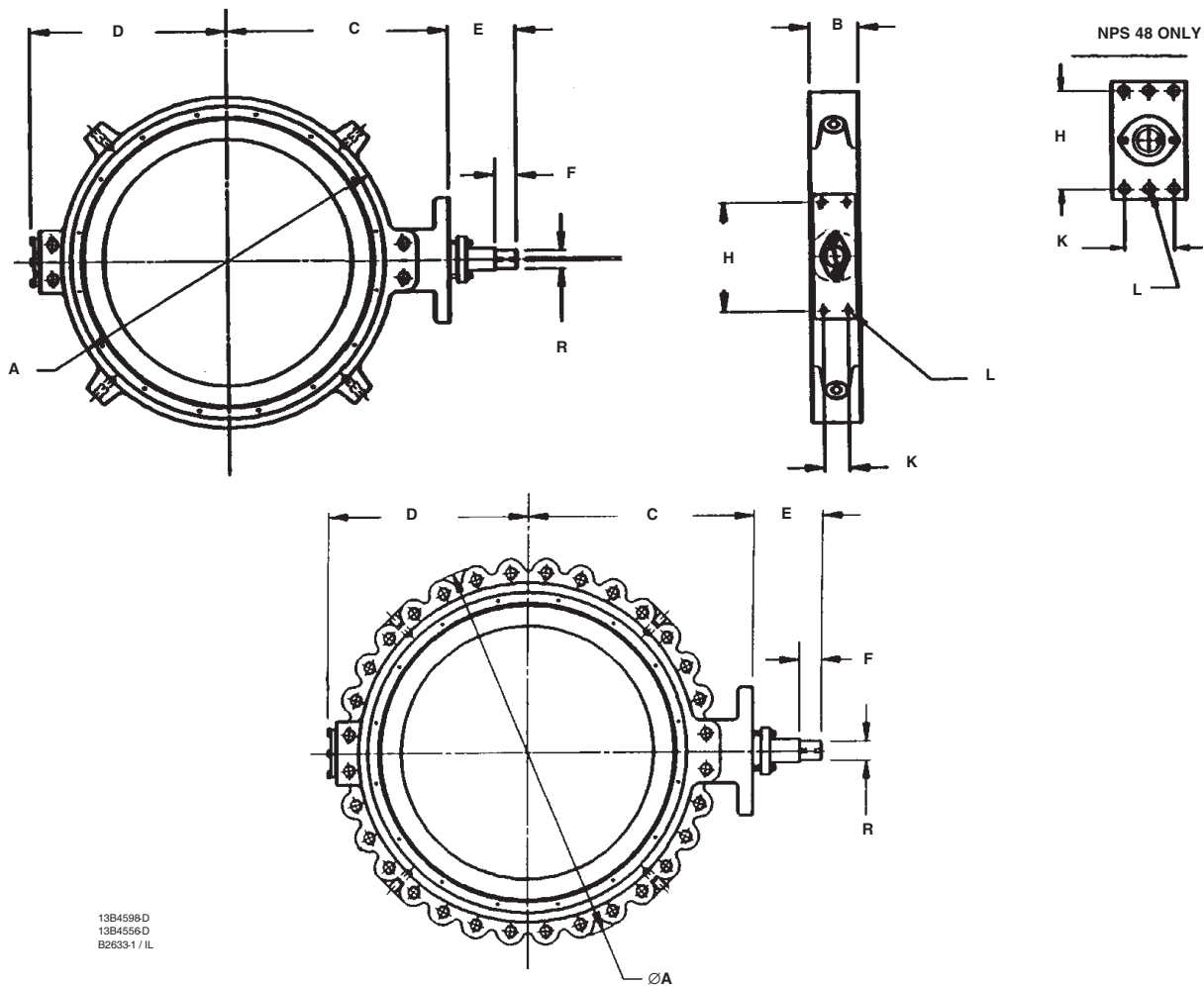

Figure 4. Dimensions and Weights Wafer Style and Single Flange CL150/150 (also see table 17)

Product Bulletin

21.1:A11
April 2010

A11 Valve

Table 18. Dimensions and Weights Wafer and Single Flange Style CL150

VALVE SIZE, NPS	A		B	C	D	E	F	H	J(1)	K	L	M(2)	R	KEY SQ SIZE	APPROX WEIGHT
	Wafer	Single Flange													
mm															
30	866.6	991	158.8	590.6	520.7	314.5	114.3	336.6	See Thread Info Below	76.2	See Thread Info Below	735.8	69.9	15.9	528
36	1031.7	1175	177.8	657.4	619.3	314.5	114.3	304.8		152.4		887.7	69.9	15.9	806
42	1050	1360	228.6	838.2	730.3	314.5	114.3	304.8		152.4		1028.2	69.9	15.9	1302
48	1371.6	1524	260.4	901.7	797.1	314.5	114.3	508.0		203.2		1110.9	69.9	15.9	1904
Inches															
30	34.12	39.00	6.25	23.25	20.50	12.38	4.5	13.25	1-1/4-8	3.00	7/8-9	28.97	2-3/4	5/8	1164
36	40.62	46.25	7.00	25.88	24.38	12.38	4.5	12.00	1-1/2-8	6.00	1-1/4-7	34.95	2-3/4	5/8	1778
42	47.50	53.56	9.00	33.00	28.75	12.38	4.5	12.00	1-1/2-8	6.00	1-1/4-7	40.48	2-3/4	5/8	2871
48	54.00	60.00	10.25	35.50	31.38	12.38	4.5	20.00	1-1/2-8	8.00	1-1/4-7	46.09	2-3/4	5/8	4198

1. This value applies to Single Flange style only.
2. M dimension is disc chordal swing diameter.

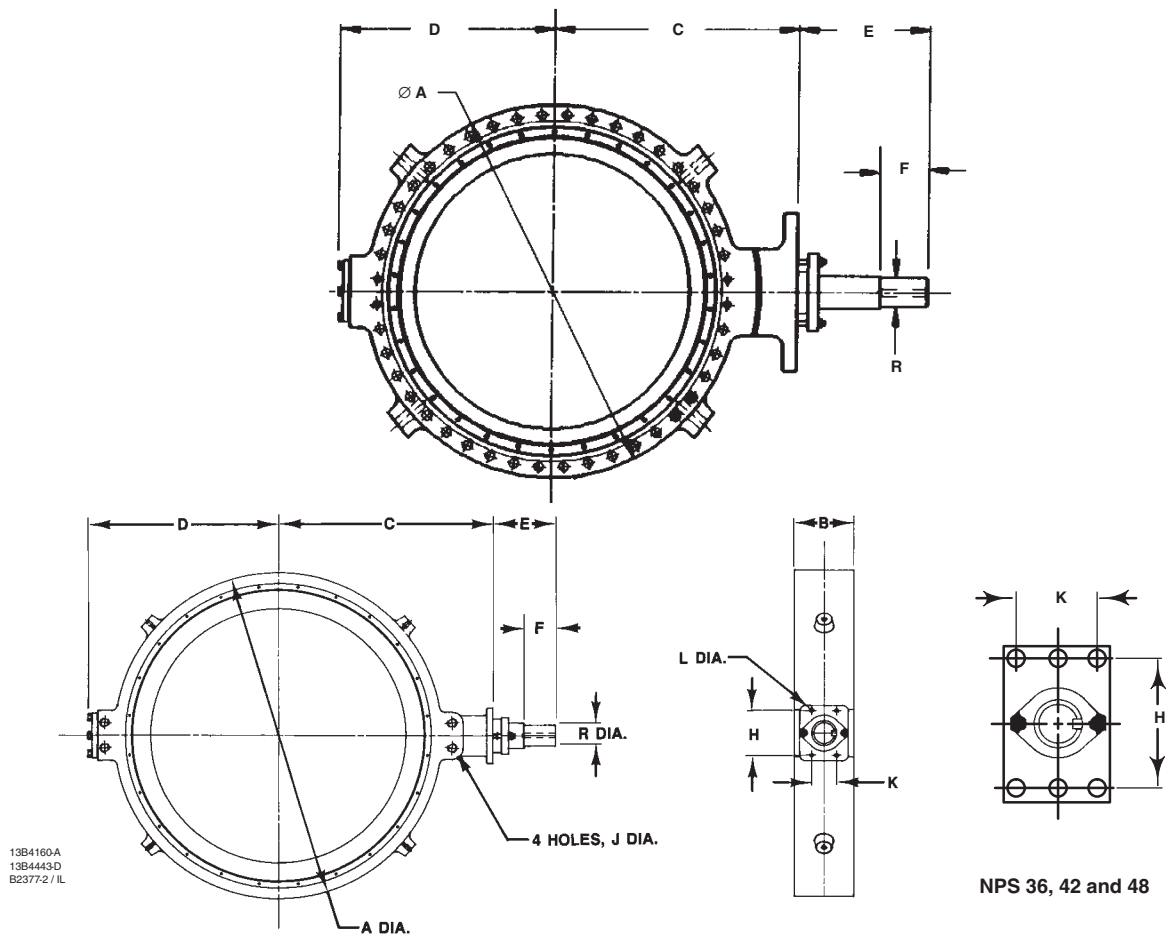

Figure 5. Dimensions and Weights Wafer and Single Flange Style CL150 (also see table 18)

Table 19. Dimensions and Weights Wafer and Single Flange Style CL300

VALVE SIZE NPS	A		B	C	D	E	F	H	J ⁽¹⁾	K	L	M ⁽²⁾	R	KEY SQ SIZE	APPROX WEIGHT
	Wafer	Single Flange													
mm															
30	865	1105	241	648	576	314	114.3	508	See Thread Info Below	203	See Thread Info Below	681	70	15.9	952
36	1035	1286	273	740	675	353	152.4	432		203		838	95	22.2	1315
42	1162	1346	299	867	768	363	163.6	432		203		943	102	25.4	2263
48	1315	1484	422	934	888	497	114.3	660		330		1125	146	38.1	3056
Inches															
30	34.06	43.50	9.50	25.50	22.69	12.38	4.5	20.00	1-3/4-8	8.00	1-1/4-7	26.80	2-3/4	5/8	2100
36	40.75	50.62	10.75	29.12	26.56	13.88	6	17.00	2-8	8.00	1-1/4-7	32.99	3-3/4	7/8	2900
42	45.75	53.00	11.75	34.12	30.25	14.31	6.44	17.00	1-5/8-8	8.00	1-1/4-7	37.13	4	1	4989
48	51.75	58.44	16.62	36.75	34.94	19.56	4.5	26.00	1-7/8-8	13.00	1-1/4-7	44.29	5-3/4	1-1/2	6738

1. Applies only to Single Flange Style.
2. M dimension is disc chordal swing diameter.

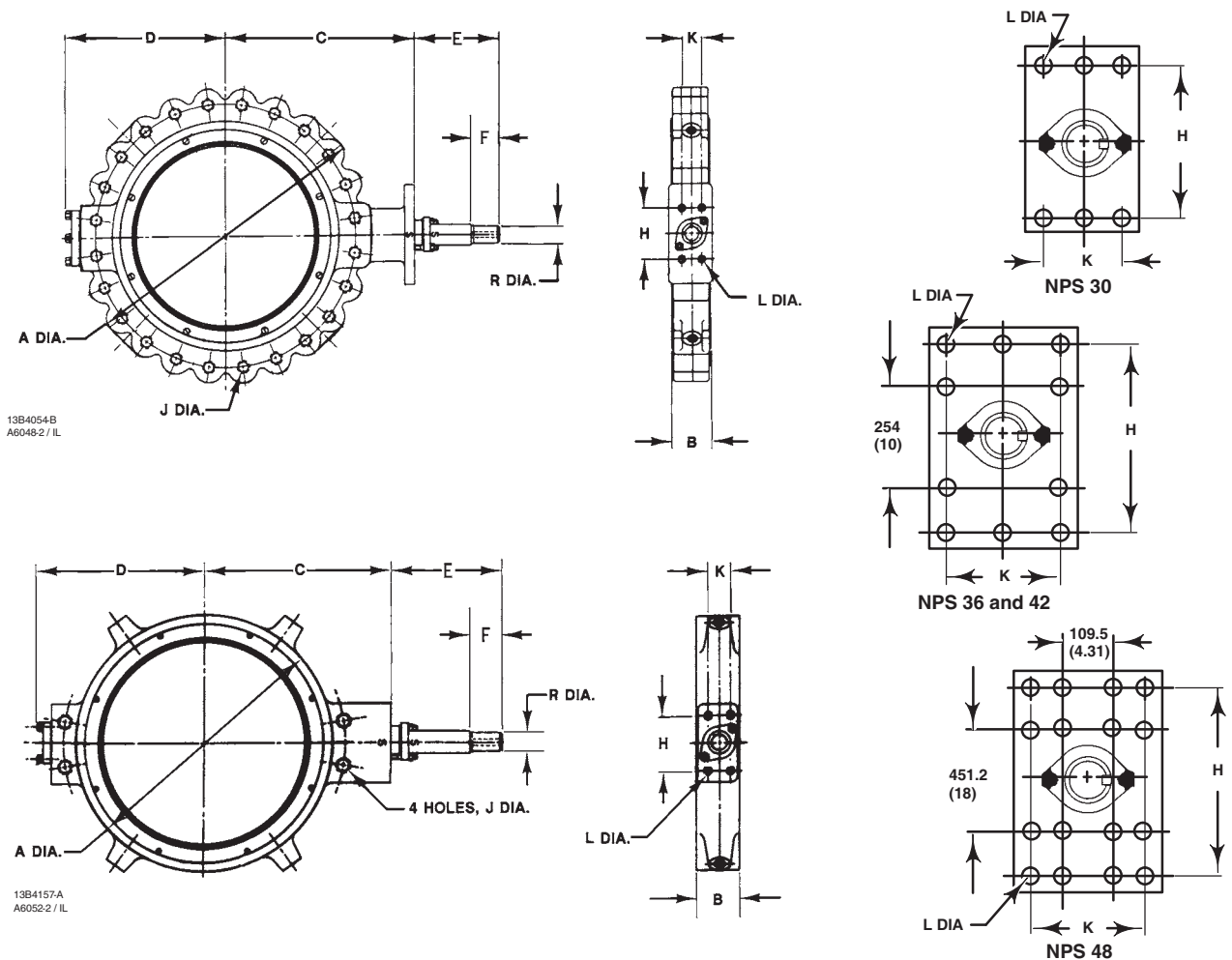

Figure 6. Dimensions and Weights Wafer and Single Flange Style CL300 (also see table 19)

Product Bulletin

21.1:A11
April 2010

A11 Valve

Table 20. Dimensions and Weights Wafer and Single Flange Style CL600

VALVE SIZE, NPS	A		B	C	D	E			F		G Square	H	K	M ⁽¹⁾	R _Ø Keyed	KEY SQ SIZE	APPROX WEIGHT
	Wafer	Single Flange				Keyed Shaft	Splined Shaft	Sq Shaft	Keyed Shaft	Splined Shaft							
mm																	
3	146	213	46	146	83	210	187	57	66.68	67	10.3	89	---	64	12.7	3.2	9
4	191	276	61	178	105	210	214	67	66.68	73	15.9	114	---	86	15.9	4.8	10
6	264	346	73	235	156	210	214	90	66.68	86	22.2	114	---	127	25.4	6.4	25
8	311	424	89	260	230	210	208	90	66.80	92	25.4	127	51	182	31.8	6.4	52
10	365	521	114	321	282	210	356	95	66.80	156	34.9	127	51	221	38.1	9.5	113
12	418	569	140	356	318	210	356	95	73.15	156	34.9	273	51	260	44.5	9.5	153
14	467	613	159	371	343	295	356	---	95.25	156	---	337	76.2	282	57.2	12.7	186
16	524	689	178	432	384	314	356	---	114.3	156	---	337	76.2	321	69.9	15.9	274
18	578	752	197	476	430	314	---	---	114.3	---	---	305	152.4	371	69.9	15.9	361
20	645	823	229	508	449	314	---	---	114.3	---	---	305	152.4	399	69.9	15.9	526
24	772	946	229	562	524	314	---	---	114.3	---	---	508	203.2	516	69.9	15.9	669
Inches																	
3	5.75	8.38	1.81	5.75	3.25	8.25	7.38	2.25	2.625	2.62	13/32	3.50	---	2.52	1/2	1/8	20
4	7.50	10.88	2.38	7.00	4.12	8.25	8.44	2.62	2.625	2.88	5/8	4.50	---	3.40	5/8	3/16	23
6	10.38	13.62	2.88	9.25	6.12	8.25	8.44	3.56	2.625	3.38	7/8	4.50	---	4.98	1	1/4	54
8	12.25	16.69	3.50	10.25	9.06	8.25	8.19	3.56	2.63	3.63	1	5.00	2.00	7.17	1-1/4	1/4	115
10	14.38	20.50	4.50	12.62	11.12	8.25	14.00	3.75	2.63	6.13	1-3/8	5.00	2.00	8.70	1-1/2	3/8	249
12	16.44	22.38	5.50	14.00	12.50	8.25	14.00	3.75	2.88	6.13	1-3/8	10.75	2.00	10.22	1-3/4	3/8	337
14	18.38	24.12	6.25	14.62	13.50	11.63	14.00	---	3.75	6.13	---	13.25	3.00	11.09	2-1/4	1/2	410
16	20.62	27.12	7.00	17.00	15.12	12.38	14.00	---	4.5	6.13	---	13.25	3.00	12.63	2-3/4	5/8	605
18	22.75	29.62	7.75	18.75	16.94	12.38	---	---	4.5	---	---	12.00	6.00	14.62	2-3/4	5/8	796
20	25.38	32.38	9.00	20.00	17.69	12.38	---	---	4.5	---	---	12.00	6.00	15.71	2-3/4	5/8	1160
24	30.38	37.25	9.00	22.12	20.62	12.38	---	---	4.5	---	---	20.00	8.00	20.32	2-3/4	5/8	1475

1. M dimension is the disc chordal swing diameter.

Table 21. Dimensions and Weights Wafer and Single Flange Style CL600

VALVE SIZE, NPS	L	P ⁽¹⁾
	mm	
3	See Thread Info Below	See Thread Info Below
4		
6		
8		
10		
12		
14		
16		
18		
20		
24		
VALVE SIZE, NPS	Inches	
3	0.53	3/4-10 8 holes
4	0.53	7/8-9 8 holes
6	0.53	1-8 12 holes
8	1/2-13	1-1/8-8 12 holes
10	3/4-10	1-1/4-8 16 holes
12	3/4-10	1-1/4-8 20 holes
14	7/8-9	1-3/8-8 20 holes
16	7/8-9	1-1/2-8 20 holes
18	1-1/4-7	1-5/8-8 20 holes
20	1-1/4-7	1-5/8-8 24 holes
24	1-1/4-7	1-7/8-8 24 holes

1. This value applies to the Single Flange style only.

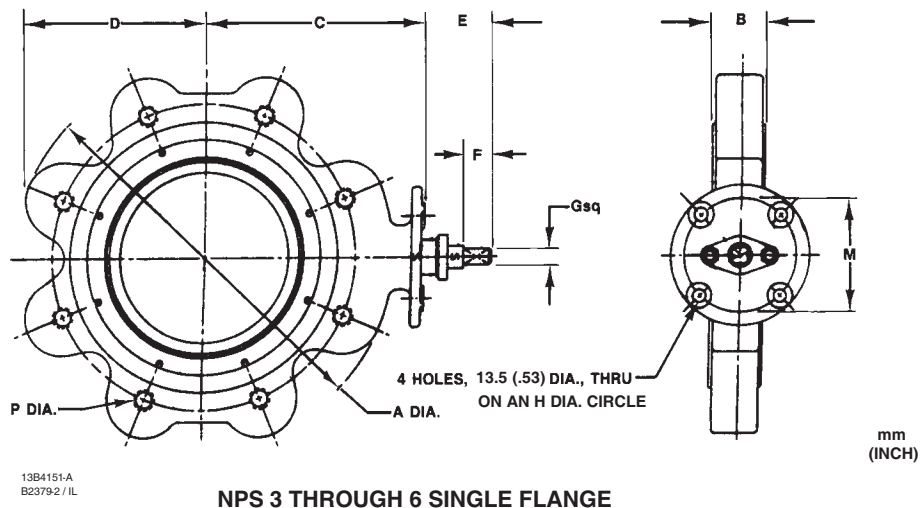
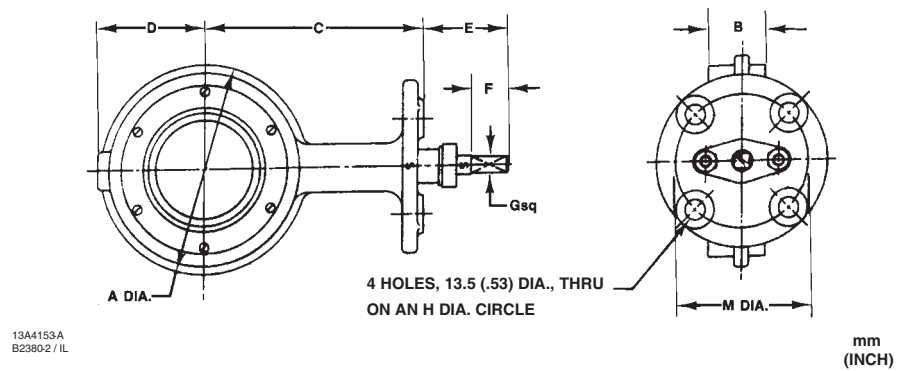

Figure 7. Dimensions and Weights Wafer and Single Flange Style CL600 (also see table 20)

A11 Valve

Table 22. Dimensions and Weights Wafer and Single Flange Style CL900

VALVE SIZE, NPS	A		B	C	D	E		F	G Square	H	K	M ⁽¹⁾	R _∅ Keyed	KEY SQ SIZE	APPROX WEIGHT
	Wafer	Single Flange				Keyed Shaft	Sq Shaft								
mm															
6	241	381	76	233	233	210	90	67	22	235	46	126	25	6	59.0
8	314	470	109	305	305	210	90	67	35	273	51	164	38	10	120
10	362	546	146	353	353	210	95	67	35	273	51	182	44	10	210
12	438	610	229	445	445	295	---	95	---	337	76	165	57	13	450
14	476	635	216	451	451	295	---	95	---	337	76	208	57	13	444
16	533	705	241	438	438	314	---	117	---	337	76	217	70	16	513
18	594	781	273	524	524	314	---	114	---	337	76	(2)	70	16	703
20	660	857	292	695	695	314	---	114	---	305	165	284	70	16	991
24	791	1041	333	657	657	314	---	117	---	572	203	366	95	22	1628
Inches															
6	9.50	15.00	3.00	9.19	9.19	8.25	3.56	2.62	0.87	9.25	1.812	4.98	1.00	1/4	130
8	12.38	18.50	4.31	12.00	12.00	8.25	3.75	2.62	1.37	10.75	2.00	6.46	1.50	3/8	264
10	14.25	21.50	5.75	13.88	13.88	8.25	3.75	2.62	1.37	10.75	2.00	7.17	1.75	3/8	463
12	17.25	24.00	9.00	17.50	17.50	11.62	---	3.75	---	13.25	3.00	6.48	2.25	1/2	993
14	18.75	25.00	8.50	17.75	17.75	11.62	---	3.75	---	13.25	3.00	8.17	2.25	1/2	978
16	21.00	27.75	9.50	17.25	17.25	12.38	---	4.62	---	13.25	3.00	8.55	2.75	5/8	1132
18	23.38	30.76	10.75	20.63	20.63	12.38	---	4.50	---	13.25	3.00	(2)	2.75	5/8	1550
20	26.00	33.75	11.50	27.38	27.38	12.38	---	4.50	---	12.00	6.50	11.19	2.75	5/8	2185
24	31.13	41.00	13.12	25.88	25.88	12.38	---	4.62	---	22.50	8.00	14.40	3.75	7/8	3590

1. M dimension is the disc chordal swing diameter.
2. Contact your Emerson Process Management sales office.

Table 23. Dimensions and Weights Wafer and Single Flange Style CL900

VALVE SIZE, NPS	L	J ⁽¹⁾
	mm	
6	See Thread Info Below	See Thread Info Below
8		
10		
12		
14		
16		
18		
20		
24		
VALVE SIZE, NPS	Inches	
6	5/8-11 4 Holes	1-1/8-8 12 Holes
8	3/4-10 4 Holes	1-3/8-8 12 Holes
10	3/4-10 4 Holes	1-3/8-8 16 Holes
12	7/8-9 4 Holes	1-3/8-8 20 Holes
14	7/8-9 4 Holes	1-1/2-8 20 Holes
16	7/8-9 4 Holes	1-5/8-8 20 Holes
18	1-1/4-7 6 Holes	1-7/8-8 20 Holes
20	1-1/4-7 6 Holes	2-8 20 Holes
24	1-1/4-7 6 Holes	2-1/2-8 20 Holes

1. This value applies to the Single Flange style only.

Product Bulletin

21.1:A11
April 2010

A11 Valve

Table 24. Dimensions and Weights Wafer and Single Flange Style CL1500

VALVE SIZE, NPS	A		B	C	D	E	F	H	K	M(1)	R _∅ Keyed	KEY SQ SIZE	APPROX WEIGHT
	Wafer	Single Flange				Keyed Shaft							
mm													kg
10	406	584	178	399	399	295	95	337	76	118	57	13	311
12	495	673	267	445	445	305	105	337	76	(3)	64	16	663
14	489	754	283	483	483	210	114	337	76	(3)	70	16	810
16	546	826	321	559	559	314	152	305	152	(3)	70	22	1152
18	683	914	349	629	629	379	164	508	203	(3)	102	25	1613
20	0	991	410	682	682	404	171	508	203	(3)	108	25	2250
Inches													lbs
10	16.00	23.00	7.00	15.69	15.69	11.62	3.75	13.25	3.00	4.63	2.25	1/2	685
12	19.50	26.50	10.50	17.50	17.50	12.00	4.13	13.25	3.00	(3)	2.50	5/8	1462
14	19.25	29.69	11.13	19.00	19.00	8.25	4.50	13.25	3.00	(3)	2.75	5/8	1785
16	21.50	21.50	12.63	22.00	22.00	12.38	6.00	12.00	6.00	(3)	2.75	7/8	2540
18	26.88	36.00	13.75	24.75	24.75	14.94	6.44	20.00	8.00	(3)	4.00	1	3555
20		39.00	16.13	26.84	26.84	15.89	6.75	20.00	8.00	(3)	4.25	1	4960

1. M dimension is the disc chordal swing diameter.
 2. This value applies to the Single Flange style only.
 3. The disc size is less than the face-to-face dimension of this valve. Therefore, the disc chordal swing is not applicable when sizing this valve.

Table 25. Dimensions and Weights Wafer and Single Flange Style CL1500

VALVE SIZE, NPS	L	J(2)
	mm	
10	See Thread Info Below	See Thread Info Below
12		
14		
16		
18		
20		
VALVE SIZE, NPS	Inches	
10	7/8-9 4 Holes	1-7/8-8 12 Holes
12	7/8-9 4 Holes	2-8 20 Holes
14	7/8-9 4 Holes	2-1/4-8 20 Holes
16	1-1/4-7 6 Holes	2-1/2-8 20 Holes
18	1-1/4-7 6 Holes	2-3/4-8 20 Holes
20	1-1/4-7 6 Holes	3-8 20 Holes

1. M dimension is the disc chordal swing diameter.
 2. This value applies to the Single Flange style only.

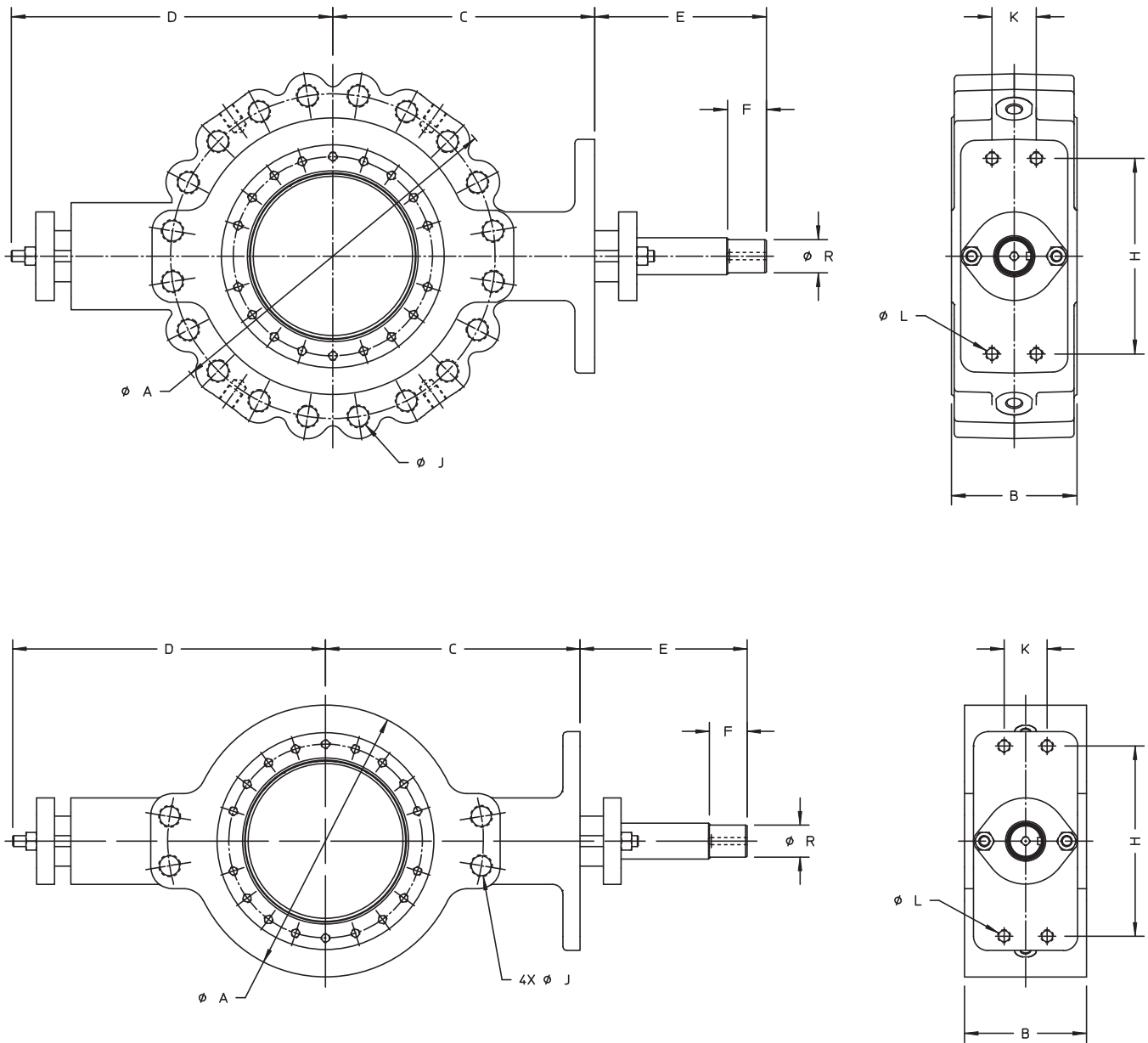

Figure 9. Dimensions and Weights Wafer and Single Flange Style CL900 and CL1500 (also see tables 22 and 24)

Coefficients

Table 26. CL150/150, Reverse Flow

CL150/150										
Coefficients	Valve Size, NPS	Valve Rotation, Degrees								
		10	20	30	40	50	60	70	80	90
C_v	30	608	2030	4460	7700	12,200	18,200	25,500	32,800	40,500
K_v		526	1760	3860	6660	10,600	15,700	22,100	28,400	35,000
F_d		0.090	0.17	0.26	0.34	0.42	0.49	0.57	0.64	0.70
F_L		0.77	0.79	0.81	0.81	0.78	0.73	0.68	0.60	0.52
X_T		0.50	0.53	0.55	0.55	0.51	0.45	0.39	0.30	0.23
C_v	36	910	3030	6670	11,500	18,200	27,300	38,200	49,100	60,600
K_v		787	2620	5770	9950	15,700	23,600	33,000	42,500	52,400
F_d		0.090	0.17	0.26	0.34	0.42	0.49	0.57	0.64	0.70
F_L		0.77	0.79	0.81	0.81	0.78	0.73	0.68	0.60	0.52
X_T		0.50	0.53	0.55	0.55	0.51	0.45	0.39	0.30	0.23
C_v	42	1200	3990	8780	15,200	24,000	35,900	50,300	64,700	79,800
K_v		1040	3450	7600	13,100	20,800	31,100	43,500	56,000	69,000
F_d		0.090	0.17	0.26	0.34	0.42	0.49	0.57	0.64	0.70
F_L		0.77	0.79	0.81	0.81	0.78	0.73	0.68	0.60	0.52
X_T		0.50	0.53	0.55	0.55	0.51	0.45	0.39	0.30	0.23
C_v	48	1590	5300	11,700	20,100	31,800	47,700	66,800	85,800	106,000
K_v		1380	4580	10,100	17,400	27,500	41,300	57,800	74,200	91,700
F_d		0.090	0.17	0.26	0.34	0.42	0.49	0.57	0.64	0.70
F_L		0.77	0.79	0.81	0.81	0.78	0.73	0.68	0.60	0.52
X_T		0.50	0.53	0.55	0.55	0.51	0.45	0.39	0.30	0.23

Table 27. CL150, Reverse Flow

CL150										
Coefficients	Valve Size, NPS	Valve Rotation, Degrees								
		10	20	30	40	50	60	70	80	90
C_v	30	508	1690	3730	6440	10,200	15,200	21,300	27,400	33,900
K_v		439	1460	3230	5570	8823	13,100	18,400	23,700	29,300
F_d		0.090	0.17	0.26	0.34	0.42	0.49	0.57	0.64	0.70
F_L		0.77	0.79	0.81	0.81	0.78	0.73	0.68	0.60	0.52
X_T		0.50	0.53	0.55	0.55	0.51	0.45	0.39	0.30	0.23
C_v	36	757	2520	5550	9590	15,100	22,700	31,800	40,900	50,500
K_v		654	2180	4800	8300	13,100	19,600	27,500	35,400	43,700
F_d		0.090	0.17	0.26	0.34	0.42	0.49	0.57	0.64	0.70
F_L		0.77	0.79	0.81	0.81	0.78	0.73	0.68	0.60	0.52
X_T		0.50	0.53	0.55	0.55	0.51	0.45	0.39	0.30	0.23
C_v	42	1090	3640	8000	13,800	21,800	32,700	45,800	58,900	72,700
K_v		943	3150	6920	11,900	18,900	28,300	39,600	50,900	62,900
F_d		0.090	0.17	0.26	0.34	0.42	0.49	0.57	0.64	0.70
F_L		0.77	0.79	0.81	0.81	0.78	0.73	0.68	0.60	0.52
X_T		0.50	0.53	0.55	0.55	0.51	0.45	0.39	0.30	0.23
C_v	48	1390	4630	10,200	17,600	27,800	41,700	58,400	75,000	92,600
K_v		1200	4000	8820	15,200	24,000	36,100	50,500	64,900	80,100
F_d		0.090	0.17	0.26	0.34	0.42	0.49	0.57	0.64	0.70
F_L		0.77	0.79	0.81	0.81	0.78	0.73	0.68	0.60	0.52
X_T		0.50	0.53	0.55	0.55	0.51	0.45	0.39	0.30	0.23

Table 28. CL300, Reverse Flow

CL300										
Coefficients	Valve Size, NPS	Valve Rotation, Degrees								
		10	20	30	40	50	60	70	80	90
C_v	30	715	1790	3700	6320	9780	14,000	18,100	21,200	23,800
K_v		618	1550	3200	5470	8460	12,100	15,700	18,300	20,600
F_d		0.090	0.17	0.26	0.34	0.42	0.49	0.57	0.64	0.70
F_L		0.78	0.81	0.81	0.79	0.75	0.69	0.62	0.56	0.52
X_T		0.51	0.55	0.55	0.53	0.47	0.40	0.33	0.26	0.23
C_v	36	1100	2760	5700	9750	15,100	21,700	28,000	32,800	36,800
K_v		952	2390	4930	8430	13,100	18,800	24,200	28,400	31,800
F_d		0.090	0.17	0.26	0.34	0.42	0.49	0.57	0.64	0.70
F_L		0.78	0.81	0.81	0.79	0.75	0.69	0.62	0.56	0.52
X_T		0.51	0.55	0.55	0.53	0.47	0.40	0.33	0.26	0.23
C_v	42	1710	4280	8840	15,100	23,400	33,700	43,400	50,800	57,100
K_v		1480	3700	7650	13,100	20,200	29,200	37,500	43,900	49,400
F_d		0.090	0.17	0.26	0.34	0.42	0.49	0.57	0.64	0.70
F_L		0.78	0.81	0.81	0.79	0.75	0.69	0.62	0.56	0.52
X_T		0.51	0.55	0.55	0.53	0.47	0.40	0.33	0.26	0.23
C_v	48	1870	4670	9650	16,500	25,500	36,700	47,300	55,400	62,200
K_v		1620	4040	8350	14,300	22,100	31,700	40,900	47,900	53,800
F_d		0.090	0.17	0.26	0.34	0.42	0.49	0.57	0.64	0.70
F_L		0.78	0.81	0.81	0.79	0.75	0.69	0.62	0.56	0.52
X_T		0.51	0.55	0.55	0.53	0.47	0.40	0.33	0.26	0.23

Table 29. CL600, Reverse Flow, NPS 3 through 6

CL600										
Coefficients	Valve Size, NPS	Valve Rotation, Degrees								
		10	20	30	40	50	60	70	80	90
C_v	3	5	16	31	51	84	122	151	169	182
K_v		4	14	27	44	73	106	131	146	157
F_d		0.090	0.17	0.26	0.34	0.42	0.49	0.57	0.64	0.70
F_L		0.78	0.81	0.81	0.79	0.73	0.66	0.59	0.55	0.52
X_T		0.51	0.55	0.55	0.52	0.45	0.37	0.29	0.25	0.23
C_v	4	8	23	43	71	116	169	209	234	252
K_v		7	20	37	61	100	146	181	202	218
F_d		0.090	0.17	0.26	0.34	0.42	0.49	0.57	0.64	0.70
F_L		0.78	0.81	0.81	0.79	0.73	0.66	0.59	0.55	0.52
X_T		0.51	0.55	0.55	0.52	0.45	0.37	0.29	0.25	0.23
C_v	6	15	46	87	144	236	344	426	477	513
K_v		13	40	75	125	204	298	368	413	444
F_d		0.090	0.17	0.26	0.34	0.42	0.49	0.57	0.64	0.70
F_L		0.78	0.81	0.81	0.79	0.73	0.66	0.59	0.55	0.52
X_T		0.51	0.55	0.55	0.52	0.45	0.37	0.29	0.25	0.23

Product Bulletin

21.1:A11
April 2010

A11 Valve

Table 30. CL600, Reverse Flow, NPS 8 through 24

CL600										
Coefficients	Valve Size, NPS	Valve Rotation, Degrees								
		10	20	30	40	50	60	70	80	90
C_v	8	35	104	197	324	532	775	960	1080	1160
K_v		30	90	170	280	460	670	830	934	1000
F_d		0.090	0.17	0.26	0.34	0.42	0.49	0.57	0.64	0.70
F_L		0.78	0.81	0.81	0.79	0.73	0.66	0.59	0.55	0.52
X_T		0.51	0.55	0.55	0.52	0.45	0.37	0.29	0.25	0.23
C_v	10	62	185	350	577	947	1380	1710	1920	2060
K_v		53	160	303	499	819	1190	1480	1660	1780
F_d		0.090	0.17	0.26	0.34	0.42	0.49	0.57	0.64	0.70
F_L		0.78	0.81	0.81	0.79	0.73	0.66	0.59	0.55	0.52
X_T		0.51	0.55	0.55	0.52	0.45	0.37	0.29	0.25	0.23
C_v	12	85	255	481	793	1300	1900	2350	2630	2830
K_v		74	221	416	686	1120	1640	2030	2270	2450
F_d		0.090	0.17	0.26	0.34	0.42	0.49	0.57	0.64	0.70
F_L		0.78	0.81	0.81	0.79	0.73	0.66	0.59	0.55	0.52
X_T		0.51	0.55	0.55	0.52	0.45	0.37	0.29	0.25	0.23
C_v	14	104	312	590	971	1600	2320	2880	3230	3470
K_v		90	270	510	840	1380	2010	2490	2790	3000
F_d		0.090	0.17	0.26	0.34	0.42	0.49	0.57	0.64	0.70
F_L		0.78	0.81	0.81	0.79	0.73	0.66	0.59	0.55	0.52
X_T		0.51	0.55	0.55	0.52	0.45	0.37	0.29	0.25	0.23
C_v	16	138	413	781	1290	2110	3080	3810	4270	4590
K_v		119	357	676	1120	1830	2660	3300	3690	3970
F_d		0.090	0.17	0.26	0.34	0.42	0.49	0.57	0.64	0.70
F_L		0.78	0.81	0.81	0.79	0.73	0.66	0.59	0.55	0.52
X_T		0.51	0.55	0.55	0.52	0.45	0.37	0.29	0.25	0.23
C_v	18	175	524	989	1630	2680	3900	4830	5410	5820
K_v		151	453	855	1410	2320	3370	4180	4680	5030
F_d		0.090	0.17	0.26	0.34	0.42	0.49	0.57	0.64	0.70
F_L		0.78	0.81	0.81	0.79	0.73	0.66	0.59	0.55	0.52
X_T		0.51	0.55	0.55	0.52	0.45	0.37	0.29	0.25	0.23
C_v	20	196	588	1110	1830	3010	4380	5430	6080	6540
K_v		170	509	960	1580	2600	3790	4700	5260	5660
F_d		0.090	0.17	0.26	0.34	0.42	0.49	0.57	0.64	0.70
F_L		0.78	0.81	0.81	0.79	0.73	0.66	0.59	0.55	0.52
X_T		0.51	0.55	0.55	0.52	0.45	0.37	0.29	0.25	0.23
C_v	24	349	1050	1980	3260	5350	7790	9650	10,800	11,600
K_v		302	908	1710	2820	4630	6740	8350	9340	10,000
F_d		0.090	0.17	0.26	0.34	0.42	0.49	0.57	0.64	0.70
F_L		0.78	0.81	0.81	0.79	0.73	0.66	0.59	0.55	0.52
X_T		0.51	0.55	0.55	0.52	0.45	0.37	0.29	0.25	0.23

Table 31. CL900, Reverse Flow

CL900										
Coefficients	Valve Size, NPS	Valve Rotation, Degrees								
		10	20	30	40	50	60	70	80	90
C_v	6	17	52	100	174	265	343	385	417	434
K_v		15	45	87	151	229	297	333	361	375
F_d		0.09	0.17	0.26	0.34	0.42	0.49	0.57	0.64	0.7
F_L		0.79	0.81	0.8	0.75	0.69	0.61	0.56	0.53	0.52
X_T		0.52	0.55	0.54	0.47	0.39	0.31	0.26	0.24	0.23
C_v	8	30	89	170	296	452	585	659	711	741
K_v		26	77	147	256	391	506	570	615	641
F_d		0.09	0.17	0.26	0.34	0.42	0.49	0.57	0.64	0.7
F_L		0.79	0.81	0.8	0.75	0.69	0.61	0.56	0.53	0.52
X_T		0.52	0.55	0.54	0.47	0.39	0.31	0.26	0.24	0.23
C_v	10	56	169	324	563	859	1112	1253	1352	1408
K_v		48	146	280	487	743	962	1084	1169	1218
F_d		0.09	0.17	0.26	0.34	0.42	0.49	0.57	0.64	0.7
F_L		0.79	0.81	0.8	0.75	0.69	0.61	0.56	0.53	0.52
X_T		0.52	0.55	0.54	0.47	0.39	0.31	0.26	0.24	0.23
C_v	12	50	151	290	504	769	995	1121	1210	1260
K_v		43	131	251	436	665	861	970	1047	1090
F_d		0.09	0.17	0.26	0.34	0.42	0.49	0.57	0.64	0.7
F_L		0.79	0.81	0.8	0.75	0.69	0.61	0.56	0.53	0.52
X_T		0.52	0.55	0.54	0.47	0.39	0.31	0.26	0.24	0.23
C_v	14	111	332	636	1106	1687	2184	2461	2654	2765
K_v		96	287	550	957	1459	1889	2129	2296	2392
F_d		0.09	0.17	0.26	0.34	0.42	0.49	0.57	0.64	0.7
F_L		0.79	0.81	0.8	0.75	0.69	0.61	0.56	0.53	0.52
X_T		0.52	0.55	0.54	0.47	0.39	0.31	0.26	0.24	0.23
C_v	16	140	421	806	1402	2138	2769	3119	3365	3505
K_v		121	364	697	1213	1849	2395	2698	2911	3032
F_d		0.09	0.17	0.26	0.34	0.42	0.49	0.57	0.64	0.7
F_L		0.79	0.81	0.8	0.75	0.69	0.61	0.56	0.53	0.52
X_T		0.52	0.55	0.54	0.47	0.39	0.31	0.26	0.24	0.23
C_v	18	182	546	1046	1820	2775	3594	4049	4367	4549
K_v		157	472	905	1574	2400	3109	3502	3777	3935
F_d		0.09	0.17	0.26	0.34	0.42	0.49	0.57	0.64	0.7
F_L		0.79	0.81	0.8	0.75	0.69	0.61	0.56	0.53	0.52
X_T		0.52	0.55	0.54	0.47	0.39	0.31	0.26	0.24	0.23
C_v	20	214	614	1228	2135	3256	4217	4751	5124	5338
K_v		185	531	1062	1847	2816	3648	4110	4432	4617
F_d		0.09	0.17	0.26	0.34	0.42	0.49	0.57	0.64	0.7
F_L		0.79	0.81	0.8	0.75	0.69	0.61	0.56	0.53	0.52
X_T		0.52	0.55	0.54	0.47	0.39	0.31	0.26	0.24	0.23
C_v	24	330	989	1895	3296	5029	6509	7333	7909	8239
K_v		285	855	1639	2851	4347	5630	6343	6841	7127
F_d		0.09	0.17	0.26	0.34	0.42	0.49	0.57	0.64	0.7
F_L		0.79	0.81	0.8	0.75	0.69	0.61	0.56	0.53	0.52
X_T		0.52	0.55	0.54	0.47	0.39	0.31	0.26	0.24	0.23

Table 32. CL1500, Reverse Flow

CL1500										
Coefficients	Valve Size, NPS	Valve Rotation, Degrees								
		10	20	30	40	50	60	70	80	90
C_v	10	44	147	265	420	553	649	700	730	737
K_v		38	127	229	363	478	561	606	631	638
F_d		0.09	0.17	0.26	0.34	0.42	0.49	0.57	0.64	0.7
F_L		0.8	0.81	0.76	0.7	0.63	0.57	0.54	0.52	0.52
X_T		0.54	0.55	0.49	0.41	0.34	0.27	0.24	0.23	0.23
C_v	12	76	153	456	722	950	1115	1204	1254	1267
K_v		66	132	394	625	822	964	1041	1085	1096
F_d		0.09	0.17	0.26	0.34	0.42	0.49	0.57	0.64	0.7
F_L		0.8	0.81	0.76	0.7	0.63	0.57	0.54	0.52	0.52
X_T		0.54	0.55	0.49	0.41	0.34	0.27	0.24	0.23	0.23
C_v	14	83	275	495	784	1032	1211	1307	1362	1376
K_v		72	238	428	678	893	1048	1131	1178	1190
F_d		0.09	0.17	0.26	0.34	0.42	0.49	0.57	0.64	0.7
F_L		0.8	0.81	0.76	0.7	0.63	0.57	0.54	0.52	0.52
X_T		0.54	0.55	0.49	0.41	0.34	0.27	0.24	0.23	0.23
C_v	16	109	363	653	1033	1360	1595	1722	1795	1813
K_v		94	314	565	894	1176	1380	1490	1553	1568
F_d		0.09	0.17	0.26	0.34	0.42	0.49	0.57	0.64	0.7
F_L		0.8	0.81	0.76	0.7	0.63	0.57	0.54	0.52	0.52
X_T		0.54	0.55	0.49	0.41	0.34	0.27	0.24	0.23	0.23
C_v	18	166	554	997	1579	2077	2438	2631	2742	2770
K_v		144	479	862	1366	1797	2109	2276	2372	2396
F_d		0.09	0.17	0.26	0.34	0.42	0.49	0.57	0.64	0.7
F_L		0.8	0.81	0.76	0.7	0.63	0.57	0.54	0.52	0.52
X_T		0.54	0.55	0.49	0.41	0.34	0.27	0.24	0.23	0.23
C_v	20	203	677	1219	1931	2540	2981	3218	3353	3387
K_v		176	586	1054	1670	2197	2579	2784	2900	2930
F_d		0.09	0.17	0.26	0.34	0.42	0.49	0.57	0.64	0.7
F_L		0.8	0.81	0.76	0.7	0.63	0.57	0.54	0.52	0.52
X_T		0.54	0.55	0.49	0.41	0.34	0.27	0.24	0.23	0.23

Table 33. CL600/300, CL900/300, and CL1500/300, Reverse Flow, NPS 3 through 18

CL600/300, CL900/300, and CL1500/300										
Coefficients	Valve Size, NPS	Valve Rotation, Degrees								
		10	20	30	40	50	60	70	80	90
C_v	3	6	14	29	50	77	111	143	167	188
K_v		5	12	25	43	67	96	124	144	163
F_d		0.09	0.17	0.26	0.34	0.42	0.49	0.57	0.64	0.70
F_L		0.78	0.81	0.81	0.79	0.75	0.69	0.62	0.56	0.52
X_T		0.51	0.55	0.55	0.53	0.47	0.40	0.33	0.26	0.23
C_v	4	12	30	63	107	166	238	307	360	404
K_v		10	26	54	93	144	206	266	311	349
F_d		0.09	0.17	0.26	0.34	0.42	0.49	0.57	0.64	0.70
F_L		0.78	0.81	0.81	0.79	0.75	0.69	0.62	0.56	0.52
X_T		0.51	0.55	0.55	0.53	0.47	0.40	0.33	0.26	0.23
C_v	6	32	81	167	285	441	635	818	958	1076
K_v		28	70	144	247	381	549	708	829	931
F_d		0.09	0.17	0.26	0.34	0.42	0.49	0.57	0.64	0.70
F_L		0.78	0.81	0.81	0.79	0.75	0.69	0.62	0.56	0.52
X_T		0.51	0.55	0.55	0.53	0.47	0.40	0.33	0.26	0.23
C_v	8	40	100	206	352	545	784	1010	1183	1329
K_v		35	87	178	304	471	678	874	1023	1150
F_d		0.09	0.17	0.26	0.34	0.42	0.49	0.57	0.64	0.70
F_L		0.78	0.81	0.81	0.79	0.75	0.69	0.62	0.56	0.52
X_T		0.51	0.55	0.55	0.53	0.47	0.40	0.33	0.26	0.23
C_v	10	71	178	367	628	971	1398	1800	2108	2369
K_v		61	154	317	543	840	1209	1557	1823	2049
F_d		0.09	0.17	0.26	0.34	0.42	0.49	0.57	0.64	0.70
F_L		0.78	0.81	0.81	0.79	0.75	0.69	0.62	0.56	0.52
X_T		0.51	0.55	0.55	0.53	0.47	0.40	0.33	0.26	0.23
C_v	12	110	276	571	975	1509	2172	2798	3276	3681
K_v		95	239	494	843	1305	1879	2420	2834	3184
F_d		0.09	0.17	0.26	0.34	0.42	0.49	0.57	0.64	0.70
F_L		0.78	0.81	0.81	0.79	0.75	0.69	0.62	0.56	0.52
X_T		0.51	0.55	0.55	0.53	0.47	0.40	0.33	0.26	0.23
C_v	14	136	341	704	1204	1863	2682	3454	4045	4545
K_v		118	295	609	1041	1611	2320	2988	3499	3931
F_d		0.09	0.17	0.26	0.34	0.42	0.49	0.57	0.64	0.70
F_L		0.78	0.81	0.81	0.79	0.75	0.69	0.62	0.56	0.52
X_T		0.51	0.55	0.55	0.53	0.47	0.40	0.33	0.26	0.23
C_v	16	169	422	873	1492	2309	3323	4280	5012	5632
K_v		146	365	755	1291	1997	2874	3702	4335	4872
F_d		0.09	0.17	0.26	0.34	0.42	0.49	0.57	0.64	0.70
F_L		0.78	0.81	0.81	0.79	0.75	0.69	0.62	0.56	0.52
X_T		0.51	0.55	0.55	0.53	0.47	0.40	0.33	0.26	0.23
C_v	18	247	617	1276	2181	3374	4856	6255	7325	8230
K_v		214	534	1104	1887	2919	4200	5411	6336	7119
F_d		0.09	0.17	0.26	0.34	0.42	0.49	0.57	0.64	0.70
F_L		0.78	0.81	0.81	0.79	0.75	0.69	0.62	0.56	0.52
X_T		0.51	0.55	0.55	0.53	0.47	0.40	0.33	0.26	0.23

Table 34. CL600/300, CL900/300, and CL1500/300, Reverse Flow, NPS 20 through 24

CL600/300, CL900/300, and CL1500/300										
Coefficients	Valve Size, NPS	Valve Rotation, Degrees								
		10	20	30	40	50	60	70	80	90
C_v	20	286	714	1477	2524	3906	5620	7240	8478	9526
K_v		247	618	1278	2183	3379	4861	6263	7333	8240
F_d		0.09	0.17	0.26	0.34	0.42	0.49	0.57	0.64	0.70
F_L		0.78	0.81	0.81	0.79	0.75	0.69	0.62	0.56	0.52
X_T		0.51	0.55	0.55	0.53	0.47	0.40	0.33	0.26	0.23
C_v	24	375	938	1939	3315	5130	7381	9508	11135	12511
K_v		324	811	1677	2867	4437	6385	8224	9632	10822
F_d		0.09	0.17	0.26	0.34	0.42	0.49	0.57	0.64	0.70
F_L		0.78	0.81	0.81	0.79	0.75	0.69	0.62	0.56	0.52
X_T		0.51	0.55	0.55	0.53	0.47	0.40	0.33	0.26	0.23

Note

Neither Emerson, Emerson Process Management, nor any of their affiliated entities assumes responsibility for the selection, use, or maintenance of any product. Responsibility for the selection, use, and maintenance of any product remains with the purchaser and end user.

Fisher, POSI-SEAL, ENVIRO-SEAL, and FieldQ are marks owned by one of the companies in the Emerson Process Management business section of Emerson Electric Co. Emerson Process Management, Emerson, and the Emerson logo are trademarks and service marks of Emerson Electric Co. All other marks are the property of their respective owners.

The contents of this publication are presented for informational purposes only, and while every effort has been made to ensure their accuracy, they are not to be construed as warranties or guarantees, express or implied, regarding the products or services described herein or their use or applicability. All sales are governed by our terms and conditions, which are available upon request. We reserve the right to modify or improve the designs or specifications of such products at any time without notice. Neither Emerson, Emerson Process Management, nor any of their affiliated entities assumes responsibility for the selection, use or maintenance of any product. Responsibility for proper selection, use, and maintenance of any product remains solely with the purchaser and end user.

Emerson Process Management

Marshalltown, Iowa 50158 USA

Sorocaba, 18087 Brazil

Chatham, Kent ME4 4QZ UK

Dubai, United Arab Emirates

Singapore 128461 Singapore

www.Fisher.com

