

**Product Bulletin**

51.3:V500  
D100054X012  
October 2009

V500 Valve

# Fisher<sup>®</sup> V500 Rotary Control Valve

The Fisher V500 eccentric plug rotary control valve controls erosive, coking, and other hard-to-handle fluids, providing either throttling or on-off operation. The flanged (figure 1) and flangeless valves feature streamlined flow passages, rugged metal trim components, and a patented, self-centering seat ring (figures 2 and 3). With these components, the V500 rotary control valve combines globe valve

ruggedness with the efficiency of a rotary valve. Matched with a Fisher power or manual actuator, the V500 rotary control valve dependably controls fluids in many process industries.

Unless otherwise noted, all NACE references are to NACE MR0175-2002.



W8380

Figure 1. Fisher V500 Flanged Rotary Control Valve with 1061 Actuator and FIELDVUE<sup>®</sup> DVC6020 Digital Valve Controller



## Specifications

### Available Configuration

- Flanged or ■ flangeless valve assembly (NPS 3 through 8 only) with reversible<sup>(1)</sup> metal or VTC (ceramic) seat ring and splined valve shaft

### Valve Sizes

- NPS 1, ■ 1-1/2, ■ 2, ■ 3, ■ 4, ■ 6, and ■ 8 DN sizes are also available (see tables 1 and 2).

### End Connection Style and Rating

- Raised-face flanges or ■ ring-type joint flanges (ASME B16.5). Valves with EN PN10 through PN100 flanges also available. Various flangeless valve sizes are available in certain ASME and EN ratings. (See tables 1 and 2 for ASME and EN availability by valve size.)

### Maximum Inlet Pressure<sup>(2)</sup>

Consistent with applicable ASME or EN flange ratings

### Maximum Pressure Drops<sup>(2)</sup>

See tables 3, 4, 5, 6 and 7

### Shutoff Classification

Class IV per ANSI/FCI 70-2 and IEC 60534-4, (0.01% of valve capacity at full travel) for either flow direction. Leak rates for full and restricted port valves are based on full port valve capacities. Reduced port valves seat at the full port diameter.

### Construction Materials

See table 8 for individual parts and table 9 for trim combinations

### Material Temperature Capability<sup>(2)</sup>

See table 8

### Flow Characteristic

Modified linear

### Flow Direction

**Reverse flow (standard):** Past valve plug and through seat ring; tends to close the valve;

recommended for erosive service

**Forward flow:** Through seat ring and past valve plug; tends to open the valve

### Flow Coefficients

See the section titled Coefficients in this bulletin, or Catalog 12

### Flow Coefficient Ratio<sup>(3)</sup>

100 to 1

### Actuator Mounting

- Right-hand or ■ left-hand as viewed from the upstream side of the valve.

Mounting position depends on the desired open valve plug position and flow direction required by operating conditions. For more information, see the Installation section.

### Valve Plug Rotation

Counterclockwise to close (when viewed from actuator side of valve) through 90 degrees of plug rotation

### Valve/Actuator Action

- With diaphragm or piston rotary actuator, field-reversible between
  - push-down-to-close (extending actuator rod closes valve) and
  - push-down-to-open (extending actuator rod opens valve)

### Packing Constructions

**PTFE V-Ring:** With one carbon-filled PTFE conductive packing ring in single, double, or leak-off arrangements

**PTFE/Bound-Composition:** With one graphited composition conductive packing ring in single, double, or leak-off arrangements

**Graphite Ribbon Packing Rings:** In single, double, or leak-off arrangements

(continued)

---

**Specifications (continued)**

**Shaft Diameters**

See figure 6

**Dimensions and Approximate Weights**

See figure 6; face-to-face dimensions conform to ISA S75.04 and IEC 60534-3-2

**Options**

■ Restricted trim (retainer and seat ring) for low-flow applications, ■ sealed bearing constructions, ■ Line flange bolts (for flangeless valves), ■ Purged bearings; ■ ENVIRO-SEAL® packing system; see figure 4 and bulletin 59.3:041, ENVIRO-SEAL Packing Systems for Rotary Valves (D101638X012) for more information

---

1. The reversible seat is not available in every trim material. Consult your Emerson Process Management sales office.  
2. The pressure or temperature limits in the referenced tables or figures, and in any applicable code limitation, should not be exceeded.  
3. Ratio of maximum flow coefficient to minimum usable flow coefficient. May also be called rangeability.

---

**Contents**

Specifications ..... 2  
Features ..... 4  
Installation ..... 14  
Coefficients ..... 16

**Tables**

Valve Size, Pressure Ratings, and Flange  
Compatibility ..... 5  
Maximum Allowable  
Shutoff Pressure Drops ..... 7  
Material Temperature Capabilities ..... 12  
Material Combinations ..... 13  
Actuator Mounting Selections ..... 14  
Dimensions ..... 15

## Features

- **Resists Damage from Erosive Flow**—Valve assembly is specifically designed to combat the process of erosion. Streamlined flow passages, rugged components, and a wide choice of erosion-resistant trim materials all promote long, dependable service life in erosive applications.

- **Long Seat Life**—Path of eccentric plug (figure 5) minimizes contact with seat ring when opening, reducing seat wear and friction. When the valve plug rotates into the seat ring, a self-lapping action occurs, improving the fit between shut-off surfaces. Full-port, S31600, CoCr-A, or VTC seat ring has two shutoff surfaces and can be easily reversed, reducing downtime.

- **Operational Versatility**—Patented self-centering seat ring and rugged plug allow forward or reverse flow with tight shutoff in either flow direction. Reverse flow direction helps move downstream turbulence away from shutoff surfaces. Full 90-degree rotation removes valve plug from flowstream, helping to reduce plug wear. Seat ring and retainer are available in full and restricted port constructions, and can easily be changed if capacity requirements change.

- **Easy Installation**—Integral valve body flanges mate with many different classes of pipeline flanges, satisfying a variety of piping requirements. Flanges help to eliminate exposed line flange bolting, shorten alignment and installation time, and promote secure valve installations and piping integrity. Flangeless valves are automatically self-centering on line bolting for easy installation.

- **Simple Assembly and Maintenance**—No special orientation, precision clamping or repetitive centering of valve plug and seat ring is required when tightening the retainer, promoting accurate alignment and easy assembly.

- **Improved Environmental Capabilities**—The optional ENVIRO-SEAL packing systems are designed with very smooth shaft surfaces and live loading to provide improved sealing. The seal of the ENVIRO-SEAL system can restrict emissions to less than the EPA (Environmental Protection Agency) limit of 100 ppm (parts per million).

- **Sour Service Capability**—Trim and bolting materials are available for applications handling sour service. These materials comply with the requirements of NACE MR0175-2002.

- **Rugged Construction**—Durable, solid metal or VTC seat ring and valve plug shut off tightly without deforming plug arms or employing thin ball seals. Oversized shaft diameters and rugged trim parts allow high pressure drops.

- **Reliable Performance**—Patented seat ring design (figure 3) self-centers, self-laps, and dynamically aligns with plug, giving excellent cycle life. Sealed metal bearings help prevent particle buildup and valve shaft seizure in erosive applications.

- **Choice of Construction Materials**—Plug, seat ring, and retainer are available in four levels of hardness for selection of erosion resistance.

# Product Bulletin

51.3:V500  
October 2009

# V500 Valve

Table 1. Valve Size, ASME Pressure Ratings, and Flange Compatibility (X indicates availability)

VALVE SIZE, NPS	FLANGED			FLANGELESS		
	CL150	CL300	CL600	CL150	CL300	CL600
1	X	X	X	---	---	---
1-1/2	X	X	X	---	---	---
2	X	X	X	---	---	---
3	X	X	X	X	X	X
4	X	X	X	X	X	X
6	X	X	X	X	X	---
8	X	X	X	X	X	---

Table 2. Valve Size, EN Pressure Ratings, and Flange Capability (X indicates availability)

VALVE SIZE, DN	Flanged						Flangeless					
	PN 10	PN 16	PN 25	PN 40	PN 63	PN 100	PN 10	PN 16	PN 25	PN 40	PN 63	PN 100
25	X	X	X	X	X	X	---	---	---	---	---	---
40	X	X	X	X	X	X	---	---	---	---	---	---
50	X	X	X	X	X	X	---	---	---	---	---	---
80	X	X	X	X	X	X	X	X	X	X	X	---
100	X	X	X	X	X	X	X	X	X	X	---	---
150	X	X	X	X	X	X	X	X	X	X	---	---
200	X	X	X	X	X	X	X	X	X	X	---	---

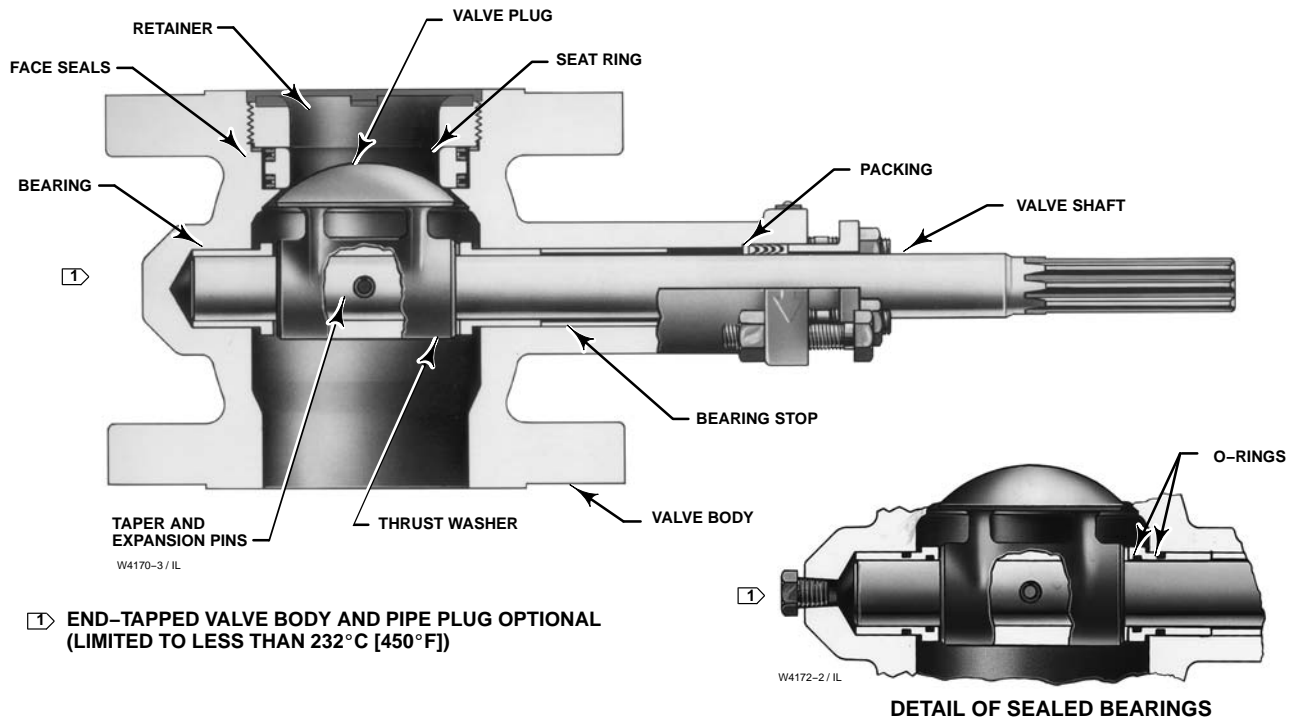

Figure 2. Sectional of Fisher V500 Control Valve

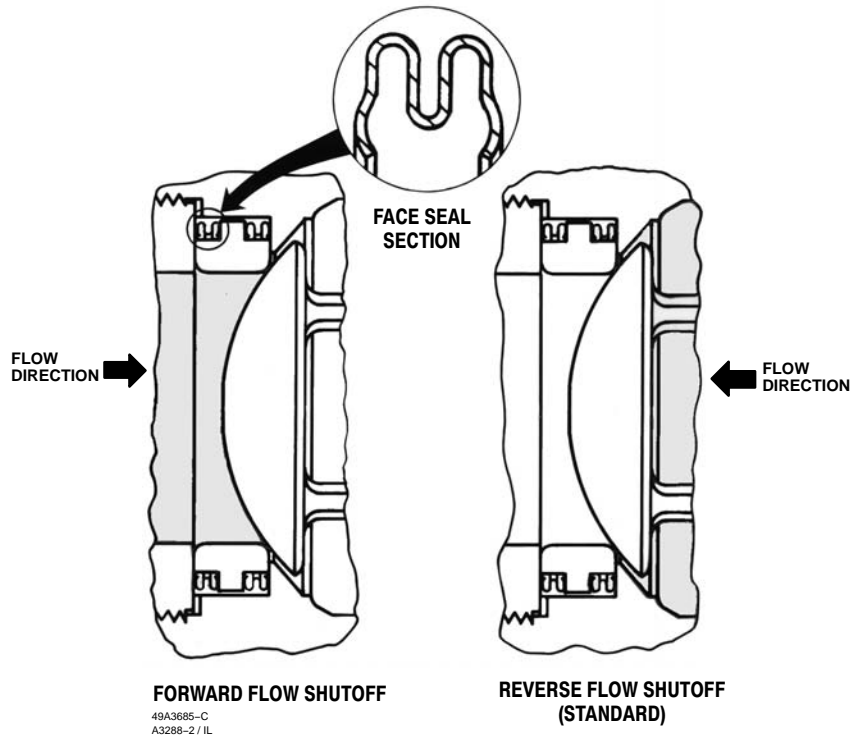

Figure 3. Detail of Seat Ring Design

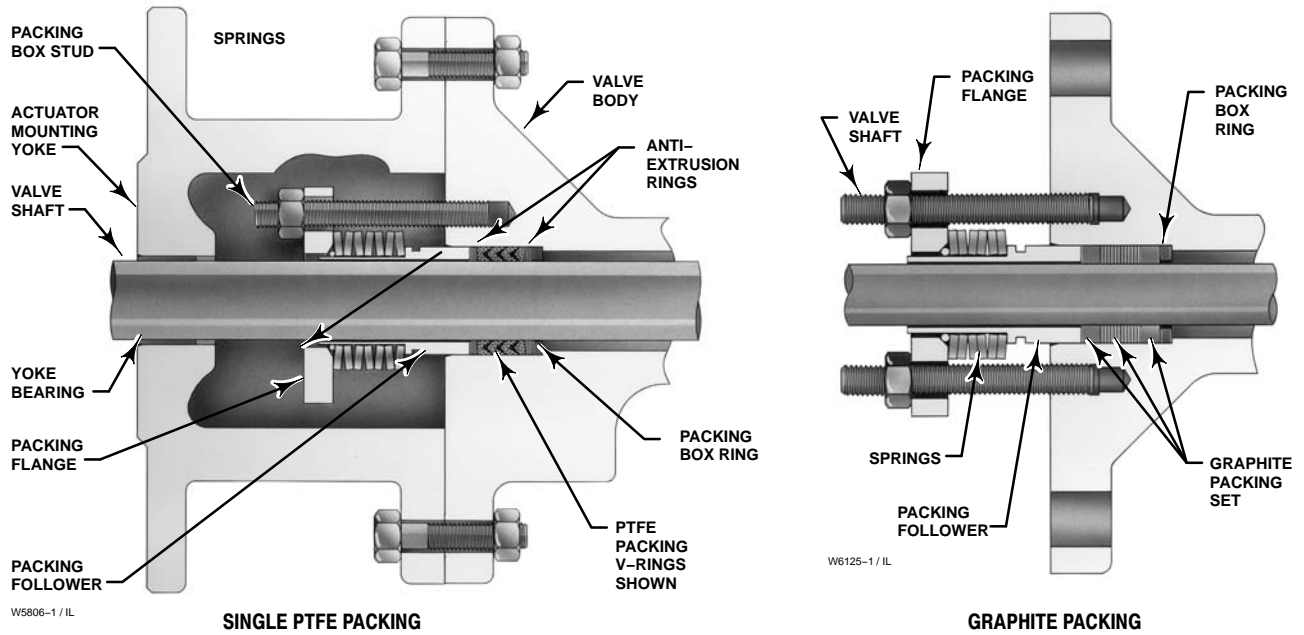

Figure 4. Typical ENVIRO-SEAL Packing Arrangements for Rotary Valves

**Product Bulletin**

51.3:V500  
October 2009

**V500 Valve**

Table 3. Maximum Allowable Shutoff Pressure Drops for Level 1 Trim, Bar

VALVE BODY MATERIAL	BEARING MATERIAL	TEMPERATURE, °C	VALVE BODY SIZE, NPS						
			1	1-1/2	2	3	4	6	8
WCC steel	S44004	-29 to 149	68.9	55.2	41.4	41.4	41.4	41.4	24.1
		149 to 204	68.9	55.2	41.4	41.4	41.4	41.4	23.8
		204 to 316	68.9	55.2	41.4	41.4	41.4	41.4	23.1
	CoCr-A	-29 to 204	68.9	55.2	41.4	41.4	41.4	20.7	15.2
		204 to 260	68.9	55.2	41.4	41.4	41.4	20.7	15.2
		260 to 316	68.9	55.2	41.4	41.4	41.4	20.7	15.2
	PTFE/ composition-lined S31600	-29 to 93	68.9	55.2	41.4	41.4	41.4	41.4	24.1
		93 to 149	68.9	55.2	41.4	41.4	41.4	41.4	24.1 <sup>(1)</sup>
									23.1 <sup>(2)</sup>
		149 to 204	68.9	55.2	41.4	41.4	41.4	41.4	23.8 <sup>(1)</sup>
									22.1 <sup>(2)</sup>
		204 to 260	68.9	55.2	41.4	41.4	41.4	41.4	23.4 <sup>(1)</sup>
21.7 <sup>(2)</sup>									
CF8M SST	CoCr-A	-46 to 20	68.9	55.2	41.4	41.4	41.4	20.7	15.2
		204 to 260	65.8	55.2	41.4	41.4	41.4	20.7	15.2
		260 to 316	62.4	55.2	41.4	41.4	41.4	20.7	15.2
	PTFE/ composition-lined S31600	-46 to 93	68.9	55.2	41.4	41.4	41.4	41.4	24.1
		93 to 149	68.9	55.2	41.4	41.4	41.4	41.4	24.1 <sup>(1)</sup>
									23.1 <sup>(2)</sup>
		149 to 204	68.9	55.2	41.4	41.4	41.4	41.4	23.8 <sup>(1)</sup>
									22.1 <sup>(2)</sup>
		204 to 260	65.8	55.2	41.4	41.4	41.4	41.4	23.4 <sup>(1)</sup>
									21.7 <sup>(2)</sup>
1. S17400 shaft only 2. ASME SA-479 Grade S20910 SST shaft only. Pressure drops appropriate for both shaft materials.									

Table 4. Maximum Allowable Shutoff Pressure Drops for Level 1 Trim, Psi

VALVE BODY MATERIAL	BEARING MATERIAL	°F	VALVE BODY SIZE, NPS								
			1	1-1/2	2	3	4	6	8		
WCC steel	S44004	-20 to 300	1000	800	600	600	600	600	600	350	
		300 to 400	1000	800	600	600	600	600	600	345	
		400 to 600	1000	800	600	600	600	600	600	335	
	CoCr-A	-20 to 400	1000	800	600	600	600	600	300	220	
		400 to 500	1000	800	600	600	600	600	300	220	
		500 to 600	1000	800	600	600	600	600	300	220	
	PTFE/ composition- lined S31600	-20 to 200	1000	800	600	600	600	600	600	350	
		200 to 300	1000	800	600	600	600	600	600	350 <sup>(1)</sup> 335 <sup>(2)</sup>	
		300 to 400	1000	800	600	600	600	600	600	345 <sup>(1)</sup> 320 <sup>(2)</sup>	
		400 to 500	1000	800	600	600	600	600	600	340 <sup>(1)</sup> 315 <sup>(2)</sup>	
		CF8M SST	CoCr-A	-50 to 400	1000	800	600	600	600	300	220
				400 to 500	955	800	600	600	600	300	220
500 to 600	905			800	600	600	600	300	220		
PTFE/ composition- lined S31600	-50 to 200		1000	800	600	600	600	600	600	350	
	200 to 300		1000	800	600	600	600	600	600	350 <sup>(1)</sup> 335 <sup>(2)</sup>	
	300 to 400		1000	800	600	600	600	600	600	345 <sup>(1)</sup> 320 <sup>(2)</sup>	
400 to 500	955	800	600	600	600	600	600	340 <sup>(1)</sup> 315 <sup>(2)</sup>			

1. S17400 shaft only  
2. ASME SA-479 Grade S20910 SST shaft only. Pressure drops appropriate for both shaft materials.

Table 5. Maximum Allowable Shutoff Pressure Drops for Level 2 and 3 Trims, Bar

VALVE BODY MATERIAL	BEARING MATERIAL	TEMPERATURE, °C	VALVE BODY SIZE, NPS						
			1	1-1/2	2	3	4	6	8
WCC steel	S44004	-29 to 93	103.4	103.4	103.4	103.4	82.7	51.7	24.1
		93 to 149	100.3	100.3	99.0	100.3	82.7	51.7	24.1
		149 to 204	97.2	97.2	93.8	97.2	82.7	51.0	23.8
		204 to 260	91.7	91.7	91.4	91.7	82.7	50.0	23.1
		260 to 316	83.4	83.4	83.4	83.4	82.7	49.3	23.1
		316 to 343	81.0	81.0	81.0	81.0	81.0	48.3	22.4
		343 to 371	78.3	78.3	78.3	78.3	78.3	48.3	22.4
		371 to 399	69.6	69.6	69.6	69.6	69.6	46.9	21.7
	399 to 427	56.9	56.9	56.9	56.9	56.9	46.9	21.7	
	CoCr-A	-29 to 204	68.9	55.2	41.4	41.4	41.4	20.7	15.2
		204 to 260	68.9	55.2	41.4	41.4	41.4	20.7	15.2
		260 to 316	68.9	55.2	41.4	41.4	41.4	20.7	15.2
		316 to 343	68.9	55.2	41.4	41.4	41.4	20.7	15.2
		343 to 371	68.9	55.2	41.4	41.4	41.4	20.7	15.2
		371 to 399	68.9	55.2	41.4	41.4	41.4	20.7	15.2
		399 to 427	56.9	55.2	41.4	41.4	41.4	20.7	15.2
	PTFE/ composition-lined S31600	-29 to 38	103.4	103.4	103.4	103.4	89.6	55.2	24.1
		38 to 93	103.4	103.4	103.4	103.4	89.6	55.2	24.1
		93 to 149	100.3	100.3	100.3	100.3	89.6	55.2	24.1 <sup>(1)</sup>
									23.1 <sup>(2)</sup>
		149 to 204	97.2	97.2	97.2	97.2	89.6	54.8 <sup>(1)</sup>	23.8 <sup>(1)</sup>
22.1 <sup>(2)</sup>									
204 to 232	91.7	91.7	91.7	91.7	89.6	53.8 <sup>(1)</sup>	23.4 <sup>(1)</sup>		
							21.7 <sup>(2)</sup>		
CF8M SST <sup>(3)</sup>	CoCr-A	-46 to 204	68.9	55.2	41.4	41.4	41.4	20.7	15.2
		204 to 260	65.8	55.2	41.4	41.4	41.4	20.7	15.2
		260 to 316	62.4	55.2	41.4	41.4	41.4	20.7	15.2
		316 to 343	61.4	55.2	41.4	41.4	41.4	20.7	15.2
		343 to 371	59.6	55.2	41.4	41.4	41.4	20.7	15.2
		371 to 399	58.3	55.2	41.4	41.4	41.4	20.7	15.2
		399 to 427	57.2	55.2	41.4	41.4	41.4	20.7	15.2
	PTFE/ composition-lined S31600	-46 to 38	99.3	99.3	99.3	99.3	89.6	55.2	24.1
		38 to 93	85.5	85.5	85.5	85.5	85.5	55.2	24.1
		93 to 149	77.3	77.3	77.3	77.3	77.2	53.1	24.1 <sup>(1)</sup>
									23.1 <sup>(2)</sup>
		149 to 204	71.0	71.0	71.0	71.0	71.0	54.8 <sup>(1)</sup>	23.8 <sup>(1)</sup>
									22.1 <sup>(2)</sup>
		204 to 232	65.8	65.8	65.8	65.8	65.8	53.8 <sup>(1)</sup>	23.4 <sup>(1)</sup>
									21.7 <sup>(2)</sup>

1. S17400 shaft only  
 2. ASME SA-479 Grade S20910 SST shaft only. Pressure drops appropriate for both shaft materials.  
 3. Level 3 trim is limited to a maximum temperature of 316°C.

Table 6. Maximum Allowable Shutoff Pressure Drops for Level 2 and 3 Trims, Psi

VALVE BODY MATERIAL	BEARING MATERIAL	TEMPERATURE, °F	VALVE BODY SIZE, NPS						
			1	1-1/2	2	3	4	6	8
WCC steel	S44004	-20 to 200	1500	1500	1500	1500	1200	750	350
		200 to 300	1455	1455	1435	1455	1200	750	350
		300 to 400	1410	1410	1360	1410	1200	740	345
		400 to 500	1330	1330	1325	1330	1200	725	335
		500 to 600	1210	1210	1210	1210	1200	715	335
		600 to 650	1175	1175	1175	1175	1175	700	325
		650 to 700	1135	1135	1135	1135	1135	700	325
		700 to 750	1010	1010	1010	1010	1010	680	315
	750 to 800	825	825	825	825	825	680	315	
	CoCr-A	-20 to 400	1000	800	600	600	600	300	220
		400 to 500	1000	800	600	600	600	300	220
		500 to 600	1000	800	600	600	600	300	220
		600 to 650	1000	800	600	600	600	300	220
		650 to 700	1000	800	600	600	600	300	220
		700 to 750	1000	800	600	600	600	300	220
	PTFE/ composition- lined S31600	-20 to 100	1500	1500	1500	1500	1300	800	350
		100 to 200	1500	1500	1500	1500	1300	800	350
		200 to 300	1455	1455	1455	1455	1300	800	350 <sup>(1)</sup> 335 <sup>(2)</sup>
		300 to 400	1410	1410	1410	1410	1300	795 <sup>(1)</sup> 740 <sup>(2)</sup>	345 <sup>(1)</sup> 320 <sup>(2)</sup>
		400 to 450	1330	1330	1330	1330	1330	780 <sup>(1)</sup> 725 <sup>(2)</sup>	340 <sup>(1)</sup> 315 <sup>(2)</sup>
CF8M SST <sup>(3)</sup>	CoCr-A	-50 to 400	1000	800	600	600	600	300	220
		400 to 500	955	800	600	600	600	300	220
		500 to 600	905	800	600	600	600	300	220
		600 to 650	890	800	600	600	600	300	220
		650 to 700	865	800	600	600	600	300	220
		700 to 750	845	800	600	600	600	300	220
		750 to 800	830	800	600	600	600	300	220
	PTFE/ composition- lined S31600	-50 to 100	1440	1440	1440	1440	1300	800	350
		100 to 200	1240	1240	1240	1240	1240	800	350
		200 to 300	1120	1120	1120	1120	1120	770	350 <sup>(1)</sup> 335 <sup>(2)</sup>
		300 to 400	1030	1030	1030	1030	1030	795 <sup>(1)</sup> 740 <sup>(2)</sup>	345 <sup>(1)</sup> 320 <sup>(2)</sup>
		400 to 450	955	955	955	955	955	780 <sup>(1)</sup> 725 <sup>(2)</sup>	340 <sup>(1)</sup> 315 <sup>(2)</sup>

1. S17400 shaft only  
 2. ASME SA-479 Grade S20910 SST shaft only. Pressure drops appropriate for both shaft materials.  
 3. Level 3 trim is limited to a maximum temperature of 600°F.

Table 7. Maximum Allowable Shutoff Pressure Drops for Level 4 Trim<sup>(1)</sup>

VALVE BODY MATERIAL	BEARING MATERIAL	TEMPERATURE, °C	BAR						
			VALVE SIZE, NPS						
			1	1-1/2	2	3	4	6	8
WCC steel	S44004	-29 to 93	103.4	103.4	70.3	103.4	78.6	52.4	24.1
		93 to 149	100.3	100.3	70.3	100.3	78.6	52.4	24.1
		149 to 204	97.2	97.2	70.3	97.2	78.6	51.0	23.8
		204 to 260	91.7	91.7	70.3	91.7	78.6	50.0	23.1
		260 to 316	83.4	83.4	70.3	83.4	78.6	49.3	23.1
		316 to 371	78.3	78.3	70.3	78.3	78.3	48.3	22.4
	CoCr-A	-29 to 204	68.9	55.2	41.4	41.4	41.4	20.7	15.2
		204 to 260	68.9	55.2	41.4	41.4	41.4	20.7	15.2
		260 to 316	68.9	55.2	41.4	41.4	41.4	20.7	15.2
		316 to 371	68.9	55.2	41.4	41.4	41.4	20.7	15.2
CF8M SST	CoCr-A	-46 to 204	68.9	55.2	41.4	41.4	41.4	20.7	15.2
		204 to 260	65.8	55.2	41.4	41.4	41.4	20.7	15.2
		260 to 316	62.4	55.2	41.4	41.4	41.4	20.7	15.2
		316 to 371	59.6	55.2	41.4	41.4	41.4	20.7	15.2
		371 to 427	57.2	55.2	41.4	41.4	41.4	20.7	15.2
VALVE BODY MATERIAL	BEARING MATERIAL	TEMPERATURE, °F	PSI						
			1	1-1/2	2	3	4	6	8
WCC steel	S44004	-20 to 200	1500	1500	1020	1500	1140	750	350
		200 to 300	1455	1455	1020	1455	1140	760	350
		300 to 400	1410	1410	1020	1410	1140	740	345
		400 to 500	1330	1330	1020	1330	1140	725	335
		500 to 600	1210	1210	1020	1210	1140	715	335
		600 to 700	1135	1135	1020	1135	1135	700	325
	CoCr-A	700 to 800	825	825	825	825	825	680	315
		-20 to 400	1000	800	600	600	600	300	220
		400 to 500	1000	800	600	600	600	300	220
		500 to 600	1000	800	600	600	600	300	220
CF8M SST	CoCr-A	600 to 700	1000	800	600	600	600	300	220
		700 to 800	825	800	600	600	600	300	220
		-50 to 400	1000	800	600	600	600	300	220
		400 to 500	955	800	600	600	600	300	220
		500 to 600	905	800	600	600	600	300	220
600 to 700	855	800	600	600	600	300	220		
700 to 800	830	800	600	600	600	300	220		

1. VTC trim is incompatible with water and steam above 180°C (360°F).

Table 8. Material Temperature Capabilities<sup>(1)</sup>

PART NAME	MATERIAL		MINIMUM TO MAXIMUM TEMPERATURE	
			°C	°F
Valve body and retainer NPS 1 and 1-1/2	Steel body	S31600 retainer S31600 retainer with CoCr-A bore S31600 retainer with VTC bore	-29 to 427	-20 to 800
	CF8M body	S31600 retainer S31600 retainer with CoCr-A bore S31600 retainer with VTC bore	-198 to 538	-325 to 1000
Valve body and retainer NPS 2 through 8	WCC steel body	S17400 retainer	-29 to 427	-20 to 800
		Solid CoCr-A retainer	-29 to 427	-20 to 800
		S31600 retainer	-29 to 260	-20 to 500
		CoCr-A retainer with VTC bore	-29 to 427	-20 to 800
	CF8M body	S31600 retainer	-198 to 427	-325 to 800
		Solid CoCr-A retainer	-46 to 324	-50 to 600
		S31600 with CoCr-A bore	-198 to 427	-325 to 800
		CoCr-A retainer with VTC bore	-46 to 427	-50 to 800
Seat ring	S31600		-198 to 538	-325 to 1000
	Solid CoCr-A		-46 to 538	-50 to 1000
	S31600 with CoCr-A seat		-198 to 538	-325 to 1000
	Solid VTC		-46 to 427	-50 to 800
Valve plug	Chrome-plated S31600		-198 to 316	-325 to 600
	Solid CoCr-A		-46 to 538	-50 to 1000
	S31600 with CoCr-A face (NPS 6 and 8 valves only)		-198 to 538	-325 to 1000
	Solid VTC (NPS 1 through 2 valves only)		-46 to 427	-50 to 800
	VTC surface bolted to an CoCr-A hub (NPS 3 through 8 valves only)		-46 to 427	-50 to 800
Valve shaft	S17400		-62 to 427	-80 to 800
	S20910		-198 to 538	-325 to 1000
Taper and expansion pins	1 through 2-inch solid VTC valve plug	N10276	-46 to 427	-50 to 800
	Other valve plugs	S20910	-198 to 538	-325 to 1000
Bearings	PTFE/composition-lined S31600		-46 to 260	-50 to 500
	CoCr-A <sup>(2)</sup>		-198 to 538	-325 to 1000
	S44004 <sup>(2)</sup>		-29 to 427	-20 to 800
O-rings <sup>(3)</sup> (for Alloy 6 or 440C SST sealed bearings)	Fluorocarbon		-18 to 204	0 to 400
	Nitrile		-29 to 93	-20 to 200
Bearing stop	S31600		-198 to 538	-325 to 1000
Thrust washer	S17700 for S17400 shaft		-198 to 427	-325 to 800
	R30016 for S20910 SST shaft		-198 to 538	-325 to 1000
Face seals	N07718 (NACE MR0175-2002 or PTFE/N10276)		-198 to 538	-325 to 1000
Retainer gasket	Graphite laminate for NPS 1 and 1-1/2 valves or S31600 for NPS 2 through 8 valves		-198 to 538	-325 to 1000
Packing rings	PTFE		-46 to 260	-50 to 500
	PTFE/bound composition		-73 to 260	-100 to 500
	Graphite ribbon		-198 to 538	-325 to 1000
Packing follower	S31600		-198 to 538	-325 to 1000
Studs and nuts	SA-193-B7 studs and SA-194-2H nuts		-46 to 427	-50 to 800
	SA-193-B7M studs and SA-194-2HM nuts		-29 to 427	-20 to 800
	B8M studs and 8M nuts		-198 to 538	-325 to 1000
Packing box ring	S31600		-198 to 538	-325 to 1000

1. VTC trim is incompatible with water and steam above 180°C (360°F).

2. Recommended for erosive applications.

3. For sealed bearing constructions

**Product Bulletin**

51.3:V500  
October 2009

**V500 Valve**

Table 9. Material Combinations<sup>(1)</sup>

Trim Level	Plug	Seat Ring	Retainer	Valve Shaft	Bearing	O-Ring	Body	
1	Chrome-plated S31600 (NPS 1 thru 8 valves)	S31600	S17400 (WCC only), or S31600	S17400	PTFE/composition-lined S31600	---	Both	
					CoCr-A	---		
					S44004	---		
				Grade S20910	PTFE/composition-lined S31600	---	Both	
					CoCr-A	---		
2	Solid CoCr-A (NPS 1 thru 4 valves) and S31600 with CoCr-A face (NPS 6 and 8 valves)	Solid CoCr-A (NPS 1 thru 4 valves) and S31600 with CoCr-A seat (NPS 6 and 8 valves)	S17400 (WCC only), or S31600	S17400	PTFE/composition-lined S31600	---	Both	
					CoCr-A	---		
						Nitrile		WCC
						Fluorocarbon		
				S44004	---			
				Grade S20910	PTFE/composition-lined S31600	---	Both	
					CoCr-A	---		
						Nitrile		WCC
Fluorocarbon								
3	Solid CoCr-A (NPS 1 thru 8 valves)	Solid CoCr-A	S31600 with CoCr-A sleeve bore (NPS 1 and 1-1/2) Solid CoCr-A (NPS 2 thru 6)	S17400	PTFE/composition-lined S31600	---	Both	
					CoCr-C	---		
						Nitrile		WCC
						Fluorocarbon		
				Grade S20910	S44004	---	Both	
					CoCr-A	---		
						Nitrile		WCC
						Fluorocarbon		
4 <sup>(2)</sup>	Solid VTC (NPS 1 thru 2 valves) VTC plug surface bolted to CoCr-A hub, titanium grade 5 cap screw, and S31600 gasket (NPS 3 through 8 valves)	Solid VTC	S31600 with VTC bore (NPS 1 and 1-1/2 valves) Solid CoCr-A retainer with VTC bore (NPS 2 thru 8 valves)	S17400	PTFE/composition-lined S31600	---	Both	
					CoCr-A	---		
						Nitrile		WCC
						Fluorocarbon		
				Grade S20910	S44004	---	Both	
					CoCr-A	---		
						Nitrile		WCC
						Fluorocarbon		

1. NACE MR0175-2002 trim constructions are available; consult your Emerson Process Management sales office.  
2. VTC trim is incompatible with water and steam above 180°C (360°F).

Table 10. Actuator Mounting Selections, with Action and Open Plug Position Options

MOUNTING	ACTION <sup>(1)</sup>	OPEN PLUG POSITION	
		Forward Flow	Reverse Flow
Left-hand	PDTC	Below shaft	Above shaft
	PDTO	Below shaft	Above shaft
Right-hand	PDTC	Above shaft	Below shaft
	PDTO	Above shaft	Below shaft

1. PDTC—Push-down-to-close (extending actuator rod closes valve)  
PDTO—Push-down-to open (extending actuator rod opens valve).

## Installation

The V500 control valve may be installed in any position. **However, for best shutoff performance, a position with the shaft horizontal is recommended.**

The control valve may be installed in forward or reverse flow direction. Forward flow (through the seat ring and past the plug) tends to open the valve; reverse flow (past the plug and through the seat ring) tends to close the valve. The reverse flow direction is recommended for erosive applications.

Specific operating conditions may require a specific combination of push-down-to-close or -open actuator motion and open valve plug position above or below the shaft. To satisfy specific operating requirements, the complete control valve package (valve and actuator) can be assembled and installed in different ways, providing eight options for actuator motion and open plug position.

Table 10 and the appropriate actuator bulletin describe possible assembly and installation options. For assistance in selecting the appropriate combination of actuator action and open valve position, consult your Emerson Process Management sales office.

Dimensions are shown in figure 6.

## Valve Information

To determine the required valve ordering information, refer to the Specifications table. Review the information under each specification and in the referenced tables.

## Actuator and Accessory Information

Refer to the specific actuator and accessory bulletins for required ordering information.

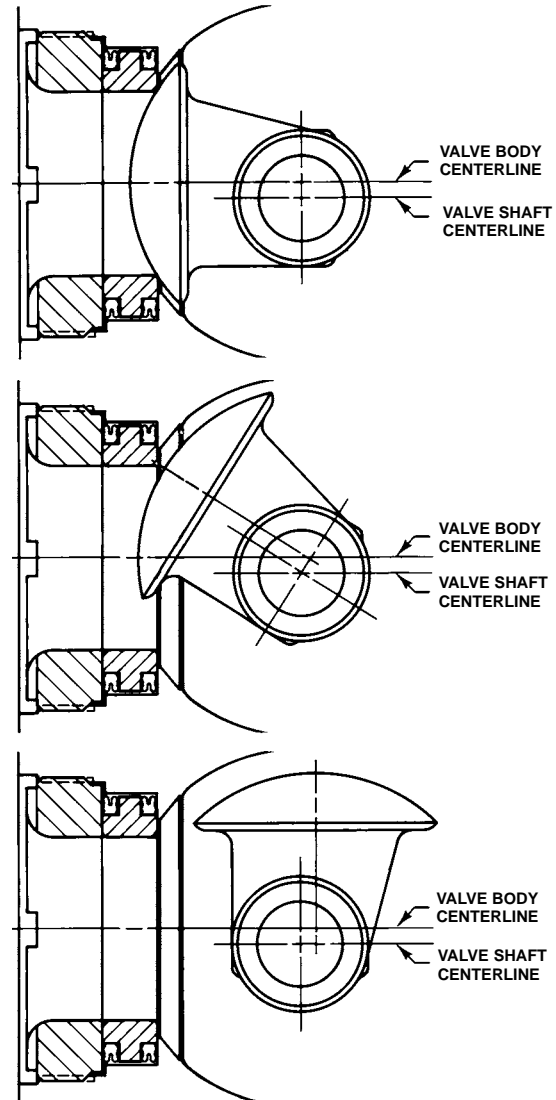

Figure 5. Eccentric Rotation

The Size 20 Fisher 1052 actuator is not available for use with V500 rotary control valves because the sizing of this combination is marginal.

# Product Bulletin

51.3:V500  
October 2009

# V500 Valve

Table 11. Fisher V500 Rotary Control Flanged and Flangeless Valve Dimensions

VALVE SIZE, DN	DIMENSIONS										APPROXIMATE WEIGHT					
	A		B		D	K	S (SHAFT DIA) <sup>(1)</sup>	T	U	W	Flanged			Flangeless		
	RF	RTJ	RF	RTJ							Pressure Class			Pressure Class		
					CL150	CL300	CL600	CL150	CL300	CL600						
mm											kg					
25	102	108	51	57	187	126	1/2	118	---	11	5.4	5.9	5.9	---	---	---
40	114	122	57	63	187	135	5/8	118	---	14	8.6	9.5	10	---	---	---
50	124	124	62	62	187	151	5/8	118	---	14	9.5	11	13	---	---	---
80	165	165	83	83	213	200	1 1 x 3/4	152	32	14	19	24	26	16	16	16
100	194	194	97	97	208	216	1-1/4	235	46	18	36	42	50	34	34	34
150	229	229	114	114	208	270	1-1/2 1-1/2 x 1-1/4	235	46	5/8-Inch 11 UNC	54	69	93	50	50	---
200	243	243	121	121	208	318	1-1/2	235	46	5/8-Inch 11 UNC	79	98	135	57	68	---
VALVE SIZE, NPS	Inches										Pounds					
1	4.00	4.25	2.00	2.25	7.38	4.97	1/2	4.62	---	0.45	12	13	13	---	---	---
1-1/2	4.50	4.75	2.25	2.50	7.38	5.31	5/8	4.62	---	0.56	19	21	23	---	---	---
2	4.88	4.88	2.44	2.44	7.38	5.94	5/8	4.62	---	0.56	21	25	28	---	---	---
3	6.50	6.50	3.25	3.25	8.44	7.88	1 1 x 3/4	6.00	1.25	0.56	42	52	57	35	35	35
4	7.62	7.62	3.81	3.81	8.19	8.50	1-1/4	9.25	1.81	0.69	79	93	111	75	75	75
6	9.00	9.00	4.50	4.50	8.19	10.6	1-1/2 1-1/2 x 1-1/4	9.25	1.81	5/8-Inch 11 UNC	120	152	204	110	110	---
8	9.56	9.56	4.78	4.78	8.19	12.5	1-1/2	9.25	1.81	5/8-Inch 11 UNC	175	217	298	125	150	---

1. Shaft diameter versus spline diameter.

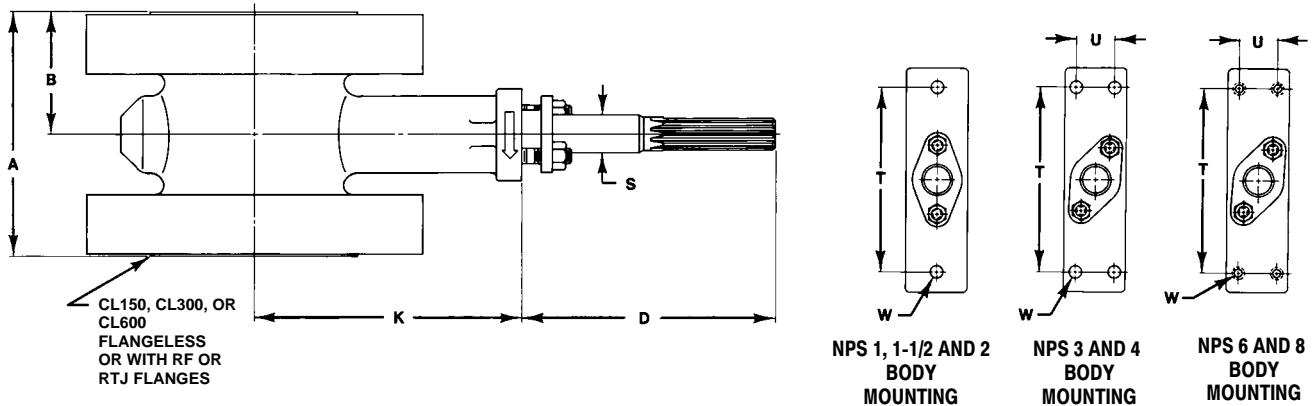

NOTE:  
FOR DIMENSIONS OF VALVES WITH DIN (OR OTHER) END CONNECTIONS,  
CONSULT YOUR EMERSON PROCESS MANAGEMENT SALES OFFICE.

A3289-1/IL

Figure 6. Fisher V500 Rotary Control Flanged and Flangeless Valve Dimensions (refer to table 11)

## Coefficients

Table 12. Fisher V500, Forward Flow, Level 1, 2 and 3 Trims Full Port

Coefficients	Valve Size, NPS	Valve Rotation, Degrees							Modified Linear Characteristic	
		10	20	30	40	50	60	70	80	90
C <sub>v</sub>	1	1.22	2.89	5.05	7.63	9.94	11.3	11.8	12.0	12.2
K <sub>v</sub>		1.06	2.50	4.37	6.60	8.60	9.77	10.2	10.4	10.6
F <sub>d</sub>		0.49	0.64	0.73	0.81	0.87	0.92	0.96	0.99	1.00
F <sub>L</sub>		0.89	0.89	0.88	0.85	0.85	0.85	0.85	0.85	0.85
X <sub>T</sub>		0.480	0.497	0.508	0.548	0.597	0.632	0.636	0.612	0.593
C <sub>v</sub>	1-1/2	2.07	6.15	11.5	16.6	20.7	23.5	25.3	26.1	26.6
K <sub>v</sub>		1.79	5.32	9.95	14.4	17.9	20.3	21.9	22.6	23.0
F <sub>d</sub>		0.48	0.63	0.73	0.81	0.87	0.92	0.96	0.99	1.00
F <sub>L</sub>		0.95	0.85	0.85	0.84	0.84	0.84	0.84	0.84	0.84
X <sub>T</sub>		0.770	0.476	0.483	0.555	0.616	0.636	0.632	0.601	0.589
C <sub>v</sub>	2	4.11	8.73	16.7	27.0	37.2	43.4	45.8	46.2	46.2
K <sub>v</sub>		3.56	7.55	14.4	23.4	32.2	37.5	39.6	40.0	40.0
F <sub>d</sub>		0.49	0.63	0.73	0.81	0.87	0.92	0.96	0.99	1.00
F <sub>L</sub>		0.97	0.92	0.84	0.79	0.77	0.75	0.75	0.74	0.74
X <sub>T</sub>		0.439	0.442	0.442	0.422	0.422	0.462	0.452	0.442	0.442
C <sub>v</sub>	3	8.80	22.7	43.3	71.3	96.8	116	130	138	142
K <sub>v</sub>		7.61	19.6	37.5	61.7	83.7	100	112	119	123
F <sub>d</sub>		0.46	0.62	0.73	0.81	0.87	0.92	0.96	0.99	1.00
F <sub>L</sub>		0.86	0.84	0.83	0.83	0.83	0.82	0.78	0.77	0.77
X <sub>T</sub>		0.469	0.544	0.574	0.526	0.497	0.526	0.508	0.476	0.456
C <sub>v</sub>	4	16.6	41.3	79.1	123	166	203	230	247	255
K <sub>v</sub>		14.3	35.7	68.4	106	144	176	199	214	221
F <sub>d</sub>		0.45	0.61	0.72	0.81	0.87	0.92	0.96	0.99	1.00
F <sub>L</sub>		0.85	0.82	0.81	0.81	0.80	0.79	0.77	0.76	0.76
X <sub>T</sub>		0.439	0.555	0.501	0.466	0.473	0.490	0.480	0.459	0.442
C <sub>v</sub>	6	17.5	79.1	155	270	363	434	492	540	565
K <sub>v</sub>		15.1	68.4	134	234	314	375	426	467	489
F <sub>d</sub>		0.44	0.60	0.72	0.81	0.87	0.92	0.96	0.99	1.00
F <sub>L</sub>		0.97	0.93	0.88	0.82	0.76	0.73	0.72	0.71	0.71
X <sub>T</sub>		0.879	0.585	0.540	0.456	0.439	0.432	0.436	0.426	0.416
C <sub>v</sub>	8	51.5	146	298	481	646	775	879	981	1050
K <sub>v</sub>		44.5	126	258	416	559	670	760	849	908
F <sub>d</sub>		0.43	0.59	0.72	0.80	0.87	0.92	0.96	0.99	1.00
F <sub>L</sub>		0.97	0.93	0.87	0.78	0.72	0.71	0.70	0.69	0.67
X <sub>T</sub>		0.456	0.605	0.533	0.449	0.413	0.403	0.391	0.372	0.360

# Product Bulletin

51.3:V500  
October 2009

# V500 Valve

Table 13. Fisher V500, Reverse Flow, Level 1, 2, and 3 Trims Full Port

Coefficients	Valve Size, NPS	Valve Rotation, Degrees						Modified Linear Characteristic		
		10	20	30	40	50	60	70	80	90
C <sub>v</sub>	1	1.08	2.82	5.26	9.11	12.4	14.7	15.9	16.4	16.8
K <sub>v</sub>		0.93	2.44	4.55	7.88	10.7	12.7	13.8	14.2	14.5
F <sub>d</sub>		0.49	0.64	0.73	0.81	0.87	0.92	0.96	0.99	1.00
F <sub>L</sub>		0.80	0.79	0.73	0.63	0.58	0.55	0.56	0.51	0.48
X <sub>T</sub>		0.172	0.284	0.406	0.357	0.345	0.322	0.300	0.289	0.283
C <sub>v</sub>	1-1/2	1.71	5.33	11.3	18.4	24.7	28.6	30.1	30.7	31.0
K <sub>v</sub>		1.48	4.61	9.77	15.9	21.4	24.7	26.0	26.6	26.8
F <sub>d</sub>		0.48	0.63	0.73	0.81	0.87	0.92	0.96	0.99	1.00
F <sub>L</sub>		0.75	0.74	0.70	0.66	0.64	0.63	0.63	0.63	0.63
X <sub>T</sub>		0.357	0.442	0.432	0.397	0.369	0.360	0.360	0.357	0.357
C <sub>v</sub>	2	2.98	7.40	15.6	27.6	41.9	52.9	56.4	57.2	57.4
K <sub>v</sub>		2.58	6.40	13.5	23.9	36.2	45.8	48.8	49.5	49.7
F <sub>d</sub>		0.49	0.63	0.73	0.81	0.87	0.92	0.96	0.99	1.00
F <sub>L</sub>		0.92	0.89	0.81	0.67	0.60	0.58	0.58	0.58	0.58
X <sub>T</sub>		0.480	0.476	0.462	0.384	0.308	0.265	0.265	0.265	0.265
C <sub>v</sub>	3	7.19	21.4	47.0	75.4	105	122	132	134	141
K <sub>v</sub>		6.22	18.5	40.7	65.2	90.8	106	114	116	122
F <sub>d</sub>		0.46	0.62	0.73	0.81	0.87	0.92	0.96	0.99	1.00
F <sub>L</sub>		0.80	0.80	0.77	0.71	0.66	0.65	0.65	0.65	0.65
X <sub>T</sub>		0.357	0.476	0.487	0.436	0.372	0.378	0.384	0.376	0.357
C <sub>v</sub>	4	12.2	39.0	79.9	124	171	202	222	232	235
K <sub>v</sub>		10.6	33.7	69.1	107	148	175	192	201	203
F <sub>d</sub>		0.45	0.61	0.72	0.81	0.87	0.92	0.96	0.99	1.00
F <sub>L</sub>		0.90	0.89	0.81	0.73	0.71	0.70	0.69	0.69	0.69
X <sub>T</sub>		0.522	0.544	0.487	0.456	0.406	0.406	0.416	0.423	0.416
C <sub>v</sub>	6	15.1	72.4	156	251	351	438	534	638	717
K <sub>v</sub>		13.1	62.6	135	217	304	379	462	552	620
F <sub>d</sub>		0.44	0.60	0.72	0.81	0.87	0.92	0.96	0.99	1.00
F <sub>L</sub>		0.85	0.85	0.82	0.77	0.70	0.66	0.61	0.57	0.51
X <sub>T</sub>		0.416	0.597	0.518	0.522	0.452	0.388	0.336	0.270	0.219
C <sub>v</sub>	8	33.5	143	302	485	663	798	871	897	986
K <sub>v</sub>		29.0	124	261	420	573	690	753	776	853
F <sub>d</sub>		0.43	0.59	0.72	0.80	0.87	0.92	0.96	0.99	1.00
F <sub>L</sub>		0.81	0.81	0.79	0.76	0.68	0.66	0.66	0.66	0.66
X <sub>T</sub>		0.697	0.593	0.483	0.410	0.354	0.342	0.366	0.403	0.363

Table 14. Fisher V500, Forward Flow, Level 1, 2, and 3 Trims Reduced Port

Coefficients	Valve Size, NPS	Valve Rotation, Degrees						Modified Linear Characteristic		
		10	20	30	40	50	60	70	80	90
C <sub>v</sub>	1	0.777	2.09	3.02	3.62	4.53	4.90	4.93	4.96	5.01
K <sub>v</sub>		0.672	1.81	2.61	3.13	3.92	4.24	4.26	4.29	4.33
F <sub>d</sub> <sup>(1)</sup>		0.54	0.66	0.75	0.82	0.88	0.92	0.96	0.99	1.00
F <sub>L</sub>		0.89	0.89	0.88	0.85	0.82	0.79	0.75	0.74	0.74
X <sub>T</sub>		0.487	0.391	0.497	0.597	0.508	0.439	0.436	0.429	0.419
C <sub>v</sub>	1-1/2	0.632	2.56	4.47	7.15	9.62	10.7	10.8	10.9	10.9
K <sub>v</sub>		.547	2.21	3.87	6.18	8.32	9.26	9.34	9.43	9.43
F <sub>d</sub> <sup>(1)</sup>		0.53	0.66	0.75	0.82	0.88	0.92	0.96	0.99	1.00
F <sub>L</sub>		0.84	0.84	0.84	0.82	0.79	0.75	0.73	0.73	0.73
X <sub>T</sub>		0.559	0.397	0.522	0.574	0.585	0.508	0.497	0.490	0.490
C <sub>v</sub>	2	1.30	3.49	5.31	9.64	15.1	17.3	17.3	17.3	17.3
K <sub>v</sub>		1.12	3.02	4.59	8.34	13.1	15.0	15.0	15.0	15.0
F <sub>d</sub> <sup>(1)</sup>		0.54	0.66	0.75	0.82	0.88	0.92	0.96	0.99	1.00
F <sub>L</sub>		0.85	0.85	0.84	0.84	0.82	0.79	0.79	0.79	0.79
X <sub>T</sub>		0.391	0.336	0.452	0.563	0.529	0.462	0.462	0.462	0.462
C <sub>v</sub>	3	6.78	11.5	16.0	26.7	40.2	47.7	48.4	48.4	48.4
K <sub>v</sub>		5.86	9.95	13.8	23.1	34.8	41.3	41.9	41.9	41.9
F <sub>d</sub> <sup>(1)</sup>		0.53	0.66	0.75	0.82	0.88	0.92	0.96	0.99	1.00
F <sub>L</sub>		0.90	0.88	0.87	0.86	0.85	0.82	0.77	0.77	0.77
X <sub>T</sub>		0.487	0.501	0.487	0.429	0.459	0.429	0.429	0.429	0.429
C <sub>v</sub>	4	10.0	18.2	24.4	43.7	69.2	90.6	98.2	98.2	98.2
K <sub>v</sub>		8.65	15.7	21.1	37.8	59.9	78.4	84.9	84.9	84.9
F <sub>d</sub> <sup>(1)</sup>		0.52	0.65	0.74	0.82	0.88	0.92	0.96	0.99	1.00
F <sub>L</sub>		0.95	0.89	0.85	0.84	0.84	0.81	0.77	0.77	0.77
X <sub>T</sub>		0.426	0.459	0.570	0.504	0.487	0.462	0.426	0.426	0.426
C <sub>v</sub>	6	9.50	26.6	41.8	76.0	129	170	200	200	200
K <sub>v</sub>		8.22	23.0	36.2	65.7	112	147	173	173	173
F <sub>d</sub> <sup>(1)</sup>		0.52	0.65	0.74	0.82	0.88	0.92	0.96	0.99	1.00
F <sub>L</sub>		0.97	0.96	0.92	0.86	0.80	0.76	0.74	0.74	0.74
X <sub>T</sub>		0.995	0.351	0.403	0.487	0.416	0.462	0.410	0.410	0.410
C <sub>v</sub>	8	39.9	87.8	155	241	343	448	541	606	623
K <sub>v</sub>		34.5	75.9	134	208	297	388	468	524	539
F <sub>d</sub> <sup>(2)</sup>		0.48	0.63	0.73	0.81	0.87	0.92	0.96	0.99	1.00
F <sub>L</sub>		0.96	0.81	0.80	0.79	0.78	0.76	0.74	0.72	0.70
X <sub>T</sub>		0.400	0.446	0.459	0.449	0.429	0.413	0.413	0.413	0.391

1. Measured at 60% Port.  
2. Measured at 40% Port.

Table 15. Fisher V500, Reverse Flow, Level 1, 2, and 3 Reduced Port

Coefficients	Valve Size, NPS	Valve Rotation, Degrees							Modified Linear Characteristic	
		10	20	30	40	50	60	70	80	90
C <sub>v</sub>	1	.634	2.09	3.34	3.96	5.21	5.64	5.70	5.71	5.76
K <sub>v</sub>		.548	1.81	2.89	3.43	4.51	4.88	4.93	4.94	4.98
F <sub>d</sub> <sup>(1)</sup>		0.54	0.66	0.75	0.82	0.88	0.92	0.96	0.99	1.00
F <sub>L</sub>		0.70	0.70	0.70	0.70	0.70	0.70	0.70	0.70	0.70
X <sub>T</sub>		0.230	0.216	0.207	0.406	0.366	0.348	0.339	0.345	0.342
C <sub>v</sub>	1-1/2	.464	1.93	4.21	7.81	11.0	12.1	12.1	12.2	12.2
K <sub>v</sub>		.401	1.67	3.64	6.76	9.52	10.5	10.5	10.6	10.6
F <sub>d</sub> <sup>(1)</sup>		0.53	0.66	0.75	0.82	0.88	0.92	0.96	0.99	1.00
F <sub>L</sub>		0.93	0.93	0.75	0.72	0.70	0.70	0.70	0.70	0.70
X <sub>T</sub>		0.970	0.416	0.501	0.467	0.416	0.416	0.416	0.413	0.416
C <sub>v</sub>	2	.965	2.68	4.82	12.0	17.7	18.7	18.8	18.9	18.9
K <sub>v</sub>		.835	2.31	4.17	10.4	15.3	16.2	16.3	16.3	16.3
F <sub>d</sub> <sup>(1)</sup>		0.54	0.66	0.75	0.82	0.88	0.92	0.96	0.99	1.00
F <sub>L</sub>		0.96	0.96	0.77	0.67	0.62	0.62	0.62	0.62	0.62
X <sub>T</sub>		0.518	0.508	0.559	0.354	0.351	0.360	0.357	0.354	0.354
C <sub>v</sub>	3	5.95	10.6	14.7	29.9	49.0	56.0	56.2	56.2	56.7
K <sub>v</sub>		5.15	9.17	12.7	25.9	42.4	48.4	48.6	48.6	49.0
F <sub>d</sub> <sup>(1)</sup>		0.53	0.66	0.75	0.82	0.88	0.92	0.96	0.99	1.00
F <sub>L</sub>		0.80	0.79	0.73	0.64	0.59	0.58	0.58	0.58	0.58
X <sub>T</sub>		0.429	0.455	0.487	0.345	0.286	0.286	0.286	0.286	0.281
C <sub>v</sub>	4	7.69	15.3	22.7	42.6	75.0	98.0	99.5	100	102
K <sub>v</sub>		6.65	13.2	19.6	36.8	64.9	84.8	86.1	86.5	88.2
F <sub>d</sub> <sup>(1)</sup>		0.52	0.65	0.74	0.82	0.88	0.92	0.96	0.99	1.00
F <sub>L</sub>		0.83	0.82	0.81	0.77	0.60	0.59	0.58	0.58	0.58
X <sub>T</sub>		0.504	0.548	0.555	0.529	0.375	0.322	0.336	0.334	0.319
C <sub>v</sub>	6	5.10	20.6	34.6	71.9	123	170	230	231	232
K <sub>v</sub>		4.41	17.8	29.9	62.2	106	147	199	200	201
F <sub>d</sub> <sup>(1)</sup>		0.52	0.65	0.74	0.82	0.88	0.92	0.96	0.99	1.00
F <sub>L</sub>		0.97	0.95	0.90	0.82	0.73	0.65	0.57	0.55	0.55
X <sub>T</sub>		0.990	0.551	0.566	0.533	0.432	0.397	0.263	0.260	0.258
C <sub>v</sub>	8	27.1	74.3	140	232	342	457	552	614	646
K <sub>v</sub>		23.4	64.3	121	201	296	395	477	531	559
F <sub>d</sub> <sup>(2)</sup>		0.48	0.63	0.73	0.81	0.87	0.92	0.96	0.99	1.00
F <sub>L</sub>		0.92	0.91	0.88	0.76	0.69	0.66	0.62	0.60	0.58
X <sub>T</sub>		0.636	0.494	0.494	0.490	0.442	0.388	0.369	0.339	0.311

1. Measured at 60% Port.  
2. Measured at 40% Port.

Table 16. Fisher V500, Forward Flow, Level 4 Trim Full Port

Coefficients	Valve Size, NPS	Valve Rotation, Degrees						Modified Linear Characteristic		
		10	20	30	40	50	60	70	80	90
C <sub>v</sub>	1	.30	1.91	4.68	7.3	9.17	10.3	11.0	11.5	11.6
K <sub>v</sub>		.260	1.65	4.05	6.31	7.93	8.91	9.52	9.95	10.0
F <sub>d</sub>		0.49	0.64	0.73	0.81	0.87	0.92	0.96	0.99	1.00
F <sub>L</sub>		---	0.98	0.87	0.87	0.85	0.86	0.85	0.86	0.84
X <sub>T</sub>		0.668	0.574	0.529	0.566	0.616	0.668	0.685	0.628	0.616
C <sub>v</sub>	1-1/2	1.46	3.79	8.13	13.4	17.9	20.7	22.4	24.0	25.0
K <sub>v</sub>		1.26	3.28	7.03	11.6	15.5	17.9	19.4	20.8	21.6
F <sub>d</sub>		0.48	0.63	0.73	0.81	0.87	0.92	0.96	0.99	1.00
F <sub>L</sub>		0.86	0.86	0.82	0.84	0.80	0.80	0.79	0.79	0.79
X <sub>T</sub>		0.566	0.605	0.55	0.544	0.551	0.574	0.589	0.585	0.597
C <sub>v</sub>	2	1.76	6.0	13.8	22.6	29.5	35.2	38.4	38.4	38.4
K <sub>v</sub>		1.52	5.19	11.9	19.5	25.5	30.4	33.2	33.2	33.2
F <sub>d</sub>		0.49	0.63	0.73	0.81	0.87	0.92	0.96	0.99	1.00
F <sub>L</sub>		0.95	0.96	0.94	0.83	0.81	0.80	0.77	0.77	0.78
X <sub>T</sub>		0.819	0.555	0.501	0.480	0.533	0.566	0.570	0.585	0.585
C <sub>v</sub>	3	7.6	23.2	44.0	62.6	82.5	102	115	119	124
K <sub>v</sub>		6.57	20.1	38.1	54.1	71.4	88.2	99.5	103	107
F <sub>d</sub>		0.46	0.62	0.73	0.81	0.87	0.92	0.96	0.99	1.00
F <sub>L</sub>		0.88	0.87	0.85	0.84	0.83	0.82	0.80	0.80	0.80
X <sub>T</sub>		0.578	0.494	0.511	0.540	0.529	0.515	0.518	0.533	0.526
C <sub>v</sub>	4	9.31	37.0	73.5	111	144	171	192	208	221
K <sub>v</sub>		8.05	32.0	63.6	96.0	125	148	166	180	191
F <sub>d</sub>		0.45	0.61	0.72	0.81	0.87	0.92	0.96	0.99	1.00
F <sub>L</sub>		0.94	0.90	0.85	0.84	0.82	0.80	0.77	0.77	0.77
X <sub>T</sub>		0.526	0.476	0.449	0.452	0.480	0.504	0.511	0.501	0.487
C <sub>v</sub>	6	9.71	64.3	141	222	299	368	426	469	499
K <sub>v</sub>		8.40	55.6	122	192	259	318	368	406	432
F <sub>d</sub>		0.44	0.60	0.72	0.81	0.87	0.92	0.96	0.99	1.00
F <sub>L</sub>		0.95	0.88	0.82	0.80	0.78	0.78	0.77	0.77	0.76
X <sub>T</sub>		0.504	0.459	0.432	0.422	0.429	0.436	0.432	0.422	0.413
C <sub>v</sub>	8	34.6	142	290	447	592	716	822	911	958
K <sub>v</sub>		29.9	123	251	387	512	619	711	788	829
F <sub>d</sub>		0.43	0.59	0.72	0.80	0.87	0.92	0.96	0.99	1.00
F <sub>L</sub>		0.92	0.76	0.78	0.79	0.77	0.76	0.73	0.71	0.73
X <sub>T</sub>		0.544	0.446	0.426	0.429	0.429	0.46	0.419	0.410	0.429

**Product Bulletin**

51.3:V500  
October 2009

**V500 Valve**

Table 17. Fisher V500, Reverse Flow, Level 4 Trim Full Port

Coefficients	Valve Size, NPS	Valve Rotation, Degrees							Modified Linear Characteristic	
		10	20	30	40	50	60	70	80	90
C <sub>v</sub>	1	.107	1.85	5.09	8.8	11.9	13.6	14.0	14.0	15.3
K <sub>v</sub>		.093	1.60	4.40	7.61	10.3	11.8	12.1	12.1	13.2
F <sub>d</sub>		0.49	0.64	0.73	0.81	0.87	0.92	0.96	0.99	1.00
F <sub>L</sub>		---	0.88	0.65	0.60	0.54	0.54	0.60	0.62	0.61
X <sub>T</sub>		0.334	0.526	0.426	0.360	0.334	0.345	0.372	0.384	0.334
C <sub>v</sub>	1-1/2	.988	3.37	7.66	13.5	19.3	23.5	25.3	25.3	26.1
K <sub>v</sub>		.854	2.92	6.63	11.7	16.7	20.3	21.9	21.9	22.6
F <sub>d</sub>		0.48	0.63	0.73	0.81	0.87	0.92	0.96	0.99	1.00
F <sub>L</sub>		0.98	0.92	0.75	0.73	0.62	0.58	0.59	0.61	0.61
X <sub>T</sub>		0.473	0.585	0.563	0.487	0.432	0.403	0.400	0.426	0.429
C <sub>v</sub>	2	1.42	4.92	11.8	20.9	29.8	36.7	40.9	42.7	43.0
K <sub>v</sub>		1.23	4.26	10.2	18.1	25.8	31.7	35.4	36.9	37.2
F <sub>d</sub>		0.49	0.63	0.73	0.81	0.87	0.92	0.96	0.99	1.00
F <sub>L</sub>		0.97	0.93	0.86	0.77	0.72	0.62	0.64	0.63	0.66
X <sub>T</sub>		0.403	0.718	0.616	0.518	0.473	0.452	0.452	0.446	0.439
C <sub>v</sub>	3	7.64	20.6	41.3	62.4	80.5	94.8	105	109	111
K <sub>v</sub>		6.61	17.8	34.9	54.0	69.6	82.0	90.8	94.3	96.0
F <sub>d</sub>		0.46	0.62	0.73	0.81	0.87	0.92	0.96	0.99	1.00
F <sub>L</sub>		0.93	0.91	0.89	0.81	0.73	0.72	0.71	0.74	0.76
X <sub>T</sub>		0.616	0.656	0.537	0.497	0.501	0.508	0.504	0.515	0.511
C <sub>v</sub>	4	8.07	31.3	67.1	102	129	153	174	189	192
K <sub>v</sub>		6.98	27.1	58.0	88.2	112	132	151	163	166
F <sub>d</sub>		0.45	0.61	0.72	0.81	0.87	0.92	0.96	0.99	1.00
F <sub>L</sub>		0.86	0.85	0.84	0.80	0.75	0.75	0.75	0.75	0.74
X <sub>T</sub>		0.456	0.664	0.533	0.490	0.515	0.526	0.522	0.504	0.515
C <sub>v</sub>	6	10.5	58.6	134	218	294	356	406	445	461
K <sub>v</sub>		9.08	50.7	116	189	254	308	351	385	399
F <sub>d</sub>		0.44	0.60	0.72	0.81	0.87	0.92	0.96	0.99	1.00
F <sub>L</sub>		0.80	0.76	0.72	0.70	0.68	0.69	0.69	0.69	0.69
X <sub>T</sub>		0.511	0.551	0.459	0.406	0.391	0.397	0.410	0.416	0.429
C <sub>v</sub>	8	25.4	136	266	413	554	686	818	895	897
K <sub>v</sub>		22.0	118	230	357	479	593	708	774	776
F <sub>d</sub>		0.43	0.59	0.72	0.80	0.87	0.92	0.96	0.99	1.00
F <sub>L</sub>		0.75	0.77	0.75	0.72	0.73	0.69	0.70	0.70	0.72
X <sub>T</sub>		0.731	0.439	0.483	0.469	0.439	0.397	0.360	0.375	0.426

Table 18. Fisher V500 Forward Flow, Level 4 Trim Reduced Port

Coefficients	Valve Size, NPS	Valve Rotation, Degrees							Modified Linear Characteristic	
		10	20	30	40	50	60	70	80	90
$C_v$	1	2.14	3.70	4.65	5.25	5.50	5.57	5.66	5.66	5.66
$K_v$		1.84	3.18	4.00	4.52	4.73	4.79	4.87	4.87	4.87
$F_d^{(1)}$		0.54	0.66	0.75	0.82	0.88	0.92	0.96	0.99	1.00
$F_L$		0.64	0.75	0.75	0.79	0.75	0.74	0.73	0.73	0.73
$X_T$		0.286	0.388	0.464	0.483	0.471	0.459	0.444	0.444	0.444
$C_v$	1-1/2	2.10	4.55	6.16	8.00	10.4	11.3	11.3	11.3	11.3
$K_v$		1.81	3.91	5.30	6.88	8.94	9.72	9.72	9.72	9.72
$F_d^{(1)}$		0.53	0.66	0.75	0.82	0.88	0.92	0.96	0.99	1.00
$F_L$		0.82	0.79	≥0.79	0.79	0.79	0.72	0.72	0.72	0.72
$X_T$		0.469	0.397	0.454	0.500	0.502	0.482	0.482	0.482	0.482
$C_v$	2	2.75	5.15	6.70	9.65	13.7	16.8	18.8	18.8	17.9
$K_v$		2.37	4.43	5.76	8.30	11.8	14.5	16.2	16.2	15.4
$F_d^{(1)}$		0.54	0.66	0.75	0.82	0.88	0.92	0.96	0.99	1.00
$F_L$		0.75	0.76	0.83	≥0.86	0.87	0.85	0.77	0.77	0.81
$X_T$		0.467	0.448	0.519	0.624	0.612	0.543	0.444	0.439	0.484
$C_v$	3	4.12	9.50	13.1	19.8	29.6	39.0	45.3	48.0	48.0
$K_v$		3.56	8.22	11.3	17.1	25.6	33.7	39.2	41.5	41.5
$F_d^{(1)}$		0.53	0.66	0.75	0.82	0.88	0.92	0.96	0.99	1.00
$F_L$		0.80	0.80	0.88	0.86	0.84	0.82	0.81	0.79	0.77
$X_T$		0.469	0.551	0.605	0.522	0.518	0.551	0.515	0.466	0.466
$C_v$	4	2.26	11.2	20.1	33.3	50.8	69.1	83.0	89.3	90.1
$K_v$		1.95	9.69	17.4	28.8	43.9	59.8	71.8	77.2	77.9
$F_d^{(1)}$		0.52	0.65	0.74	0.82	0.88	0.92	0.96	0.99	1.00
$F_L$		0.96	0.95	0.85	0.86	0.86	0.83	0.80	0.77	0.74
$X_T$		0.779	0.779	0.632	0.620	0.612	0.589	0.537	0.466	0.452
$C_v$	6	13.6	37.9	49.8	82.9	122	159	184	194	196
$K_v$		11.8	32.8	43.1	71.7	106	138	159	168	170
$F_d^{(1)}$		0.52	0.65	0.74	0.82	0.88	0.92	0.96	0.99	1.00
$F_L$		0.97	0.69	0.72	0.74	0.77	0.81	0.81	0.77	0.77
$X_T$		0.518	0.280	0.381	0.357	0.397	0.452	0.476	0.452	0.442
$C_v$	8	19.7	63.6	134	228	334	438	526	587	605
$K_v$		17.0	55.0	116	197	289	379	455	508	523
$F_d^{(2)}$		0.48	0.63	0.73	0.81	0.87	0.92	0.96	0.99	1.00
$F_L$		0.93	0.83	0.76	0.77	0.77	0.77	0.75	0.75	0.72
$X_T$		0.597	0.473	0.422	0.394	0.378	0.381	0.400	0.429	0.436

1. Measured at 60% Port.  
2. Measured at 40% Port.

Table 19. Fisher V500 Reverse Flow, Level 4 Trim Reduced Port

Coefficients	Valve Size, NPS	Valve Rotation, Degrees							Modified Linear Characteristic	
		10	20	30	40	50	60	70	80	90
C <sub>v</sub>	1	1.90	3.80	4.85	5.82	5.90	5.90	5.90	5.90	5.90
K <sub>v</sub>		1.63	3.27	4.17	5.01	5.07	5.07	5.07	5.07	5.07
F <sub>d</sub> <sup>(1)</sup>		0.54	0.66	0.75	0.82	0.88	0.92	0.96	0.99	1.00
F <sub>L</sub>		0.56	0.67	0.68	0.69	0.73	0.75	0.75	0.75	0.75
X <sub>T</sub>		0.312	0.386	0.427	0.409	0.448	0.448	0.448	0.448	0.448
C <sub>v</sub>	1-1/2	1.95	4.45	5.75	7.75	11.4	11.8	11.8	11.8	11.8
K <sub>v</sub>		1.68	3.83	4.95	6.67	9.80	10.2	10.2	10.2	10.2
F <sub>d</sub> <sup>(1)</sup>		0.53	0.66	0.75	0.82	0.88	0.92	0.96	0.99	1.00
F <sub>L</sub>		0.83	0.77	0.78	0.76	0.68	0.72	0.73	0.73	0.73
X <sub>T</sub>		0.395	0.415	0.527	0.519	0.421	0.459	0.459	0.459	0.459
C <sub>v</sub>	2	2.70	4.65	6.30	11.1	18.3	19.8	20.2	20.4	21.0
K <sub>v</sub>		2.32	4.00	5.42	9.55	15.7	17.0	17.4	17.5	18.1
F <sub>d</sub> <sup>(1)</sup>		0.54	0.66	0.75	0.82	0.88	0.92	0.96	0.99	1.00
F <sub>L</sub>		0.91	0.89	0.84	0.71	0.58	0.61	0.62	0.62	0.60
X <sub>T</sub>		0.459	0.464	0.594	0.453	0.307	0.358	0.366	0.337	0.328
C <sub>v</sub>	3	4.41	9.60	13.7	19.5	37.3	53.3	56.7	57.9	57.9
K <sub>v</sub>		3.81	8.30	11.9	16.9	32.3	46.1	49.0	50.1	50.1
F <sub>d</sub> <sup>(1)</sup>		0.53	0.66	0.75	0.82	0.88	0.92	0.96	0.99	1.00
F <sub>L</sub>		0.96	0.93	0.93	0.87	0.73	0.64	0.62	0.62	0.63
X <sub>T</sub>		0.469	0.578	0.578	0.537	0.319	0.258	0.265	0.268	0.268
C <sub>v</sub>	4	9.78	11.1	19.4	32.1	49.7	67.8	80.5	84.6	86.6
K <sub>v</sub>		8.46	9.60	16.8	27.8	43.0	58.6	69.6	73.2	74.9
F <sub>d</sub> <sup>(1)</sup>		0.52	0.65	0.74	0.82	0.88	0.92	0.96	0.99	1.00
F <sub>L</sub>		0.93	0.93	0.89	0.84	0.79	0.72	0.64	0.65	0.65
X <sub>T</sub>		0.620	0.620	0.593	0.605	0.570	0.522	0.476	0.459	0.436
C <sub>v</sub>	6	10.6	30.0	43.4	77.1	122	168	198	223	226
K <sub>v</sub>		9.17	26.0	37.5	66.7	106	145	171	193	195
F <sub>d</sub> <sup>(1)</sup>		0.52	0.65	0.74	0.82	0.88	0.92	0.96	0.99	1.00
F <sub>L</sub>		0.77	0.79	0.77	0.75	0.69	0.64	0.63	0.58	0.58
X <sub>T</sub>		0.640	0.369	0.476	0.410	0.381	0.357	0.336	0.284	0.278
C <sub>v</sub>	8	19.8	55.8	125	222	323	413	488	549	569
K <sub>v</sub>		17.1	48.3	108	192	279	357	422	475	492
F <sub>d</sub> <sup>(2)</sup>		0.48	0.63	0.73	0.81	0.87	0.92	0.96	0.99	1.00
F <sub>L</sub>		0.75	0.77	0.78	0.75	0.70	0.68	0.70	0.68	0.70
X <sub>T</sub>		0.459	0.581	0.462	0.394	0.375	0.381	0.391	0.391	0.391

1. Measured at 60% Port.  
2. Measured at 40% Port.

## **Note**

**Neither Emerson, Emerson Process Management, nor any of their affiliated entities assumes responsibility for the selection, use, or maintenance of any product. Responsibility for the selection, use, and maintenance of any product remains with the purchaser and end user.**

Fisher, FIELDVUE, and ENVIRO-SEAL are marks owned by one of the companies in the Emerson Process Management business division of Emerson Electric Co. Emerson Process Management, Emerson, and the Emerson logo are trademarks and service marks of Emerson Electric Co. All other marks are the property of their respective owners. This product may be covered under one or more of the following patents: 5,129,625; 5,131,666 and 5,542,681 or under pending patents.

The contents of this publication are presented for informational purposes only, and while every effort has been made to ensure their accuracy, they are not to be construed as warranties or guarantees, express or implied, regarding the products or services described herein or their use or applicability. All sales are governed by our terms and conditions, which are available upon request. We reserve the right to modify or improve the designs or specifications of such products at any time without notice. Neither Emerson, Emerson Process Management, nor any of their affiliated entities assumes responsibility for the selection, use or maintenance of any product. Responsibility for proper selection, use, and maintenance of any product remains solely with the purchaser and end user.

### **Emerson Process Management**

Marshalltown, Iowa 50158 USA  
Sorocaba, 18087 Brazil  
Chatham, Kent ME4 4QZ UK  
Dubai, United Arab Emirates  
Singapore 128461 Singapore

[www.Fisher.com](http://www.Fisher.com)

