

Design V150S Slurry Vee-Ball® Control Valve

The Design V150S Slurry Vee-Ball® valve shown in figure 1 mates with CL150 raised face flanges. Rugged construction, highly wear-resistant trim materials, and an unrestricted straight through flow path make the design ideal for controlling the most abrasive of slurries.

A shaft with a choice of drive connections will allow a variety of power operated actuators and valve positioners or controllers to be used.

The design is particularly effective in minimizing erosive damage to the adjoining pipework, thereby providing greater operational safety and service life when compared with other valve types.

Note

Neither Emerson, Emerson Process Management, nor any of their affiliated entities assumes responsibility for the selection, use and maintenance of any product. Responsibility for the

selection, use, and maintenance of any product remains with the purchaser and end-user.

Features

- **Fully protective trim**—The valve body, shaft, and bearings are fully protected by hard wear-resistant trim materials.
- **Pipeline and flange protection**—The throttled flow stream is guided through a specially shaped flow ring to minimize turbulence and impingement on the pipe wall. The valve can be matched to the bore size of the inlet and outlet piping in order to prevent turbulence being generated by the step resulting in scouring erosion of the flange faces, unexpected leakage, and expensive rework. In addition, both the inlet and outlet valve flange faces are protected by a portion of the hard trim.

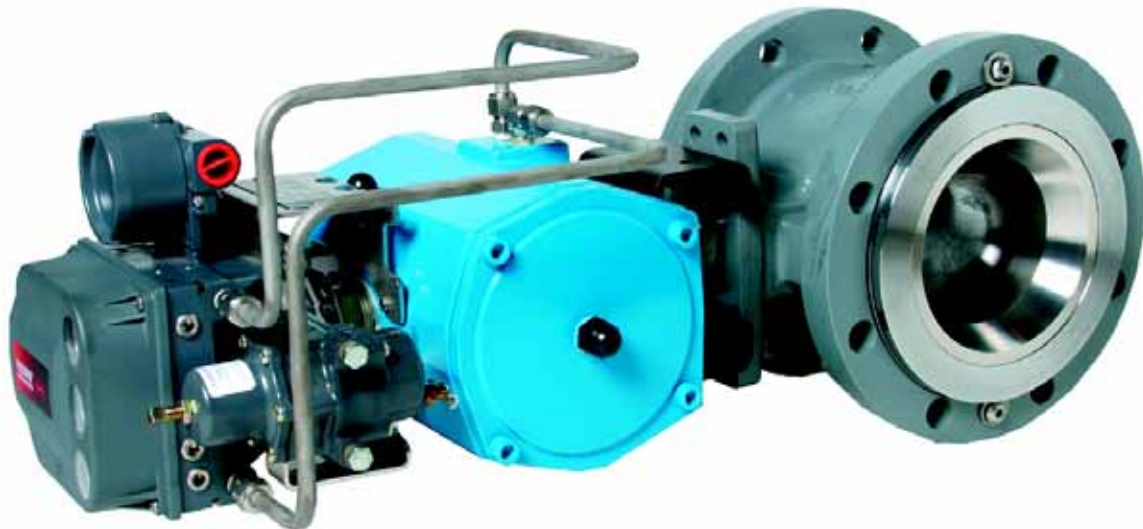

W8512-1/LL

Figure 1. Design V150S Slurry Vee-Ball® Control Valve



Slurry Vee-Ball Valve

- **Long Service Life**—The Vee-Ball design, when used in reverse flow mode, keeps the high velocity down stream of the vena contracta within the flow ring bore at the outlet of the valve. Compared with other styles of valves, the exit flow is essentially parallel with the flow ring wall and a minimum of flow impingement occurs. Combined with a choice of hard wear-resistant materials, a significantly long life is obtained.

Easily replaceable trim parts allow the valve to be overhauled at predetermined intervals and the valve body used again during repeated operational cycles.

- **Ease of installation**—Full flanging on the valve body allows the valve body to be easily aligned centrally with the pipe flanges, an essential requirement in avoiding erosion across the flange faces.

- **Excellent Flow Control**—Precise contouring of the V-notch ball provides a modified equal percentage flow characteristic. When combined with a valve actuator/controller system having minimal lost motion, improved process control can be obtained.

- **Quick and Easy Maintenance**—All trim parts are retained without the use of press fits or screw threads exposed to the process fluid. See figure 2.

- **Structural Integrity**—The valve body, complete with flanges, is made from a one-piece casting. No welding is employed. No O-ring seals are used. Use of a flanged valve body does not require the use of extra long studs.

The shaft seal is made from well-proven PTFE chevron ring packing with the means for external adjustment.

Options

- A PSZ (partially stabilized zirconia) ceramic flow ring insert is available with HCl (high chrome iron) or PSZ ceramic ball for particularly aggressive slurry services with extended lifetime requirements. The ceramic insert offers substantial increase in flow ring lifetimes.

- Trim materials are available to meet the requirements of corrosive/erosive slurries. See table 2.

- The “Flow Over the Top” V-Notch Ball offers an alternative to the standard V-Notch Ball in scaling applications.

- The drive shaft is available with either a double D or splined actuator connection to accommodate a choice of actuation between a spring-opposed diaphragm or a rack and pinion.

Specifications

Valve Sizes

■ NPS 3, ■ 4, ■ 6, ■ 8, ■ 10, and ■ 12

End Connection

V150S: CL150 Raised-face flange

Face to Face Dimension

See figure 3

Maximum Inlet Pressure

Consistent with pressure-temperature ratings per ASME B16.34 but do not exceed the material temperature capabilities shown below or the pressure drop limitations

Maximum Shut Off Pressure

See tables 3 and 4

Shutoff Classification

Class I per ANSI/FCI 70-2 and IEC 60534-4 (Class II and better not available). A defined initial maximum leak rate can be provided subject to review of service conditions.

Construction Materials

Standard Construction: See table 1

Temperature Capability

For Trim 1: 427°C (801°F) maximum
For Trims 2 and 3: 230°C (446°F) maximum
For materials: See table 1

Flow Characteristic

Approximately equal percentage

Dimensions

See figures 3 and 4

Flow Direction

Reverse flow recommended (into concave face of ball, out through the flow ring)

Flow Coefficients

See section labeled Coefficients in this bulletin

Maximum Ball Rotation

90 degrees

Valve Installation

Shaft axis to be horizontal

Actuator Mounting

Right-hand or left-hand, as viewed from upstream end of valve

Valve/Actuator Action

With diaphragm or piston rotary actuator and splined shaft, the valve is field-reversible between PDT or PDT: ■ push-down-to-close (extending actuator rod closes valve) and ■ push-down-to-open (extending actuator rod opens valve)

Actuator Size Selection

Contact your Emerson Process Management™ sales office for information

Approximate Weight

NPS 3: 15 kg (33 lb)
NPS 4: 28 kg (62 lb)
NPS 6: 45 kg (99 lb)
NPS 8: 82 kg (180 lb)
NPS 10: 120 kg (265 lb)
NPS 12: 178 kg (390 lb)

Slurry Vee-Ball Valve

Table 1. Standard Construction Materials

Part	Material	MATERIAL TEMPERATURE CAPABILITY			
		°C		°F	
		Minimum	Maximum	Minimum	Maximum
Valve Body	Carbon Steel ASTM A216 WCC	-29	427	-20	800
Body Liner	High Chrome Iron ASTM A532 Class III Type A	-29	427	-20	800
V-Notch Ball	High Chrome Iron ASTM A532 Class III Type A	-29	427	-20	800
	PSZ Ceramic (optional)	-29	427	-20	800
Flow Ring	High Chrome Iron ASTM A532 Class III Type A	-29	427	-20	800
	HCl with Ceramic Insert (optional)	-29	230	-20	450
Flow Ring Retainer	Carbon Steel ASTM A105	-29	427	-20	800
Bearing Shroud	High Chrome Iron ASTM A532 Class III Type A	-29	427	-20	800
Bearing	440C 58Rc	-29	427	-20	800
Drive Shaft	S17400 (17-4PH) Cond. H1025	-29	427	-20	800
Follower Shaft	S17400 Cond. H1025	-29	427	-20	800
Shaft Pins	420 SST	-29	427	-20	800
Gaskets	Graphite SST Laminate	-198	538	-325	1000
Packing Set	PTFE V-ring	-46	230	-50	450
	Graphite	-198	538	-325	1000
Packing Box Ring and Follower	S31600 (316 SST)	-198	538	-325	1000
Studs	B8M Class 2	-45	538	-50	1000
Nuts	S31600	-45	538	-50	1000
Retainer Screws and Clips	S31600	-45	538	-50	1000
Spring	304 SST	-29	427	-20	800
Plug	316 SST	-45	538	-50	1000

Table 2. Trim Levels

Trim Level	Ball	Flow Ring	Valve Body Liner	Bearing Shrouds
1 (standard)	HCl (High Chrome Iron)	HCl	HCl	HCl
2	HCl	HCl with ceramic insert	HCl	HCl
3	Ceramic Ball	HCl with ceramic insert	HCl	HCl

Product Bulletin

51.3:V150S
July 2007

Slurry Vee-Ball Valve

Table 3. Maximum Allowable Shutoff Pressure Drops (Valve Body Ratings) based on Carbon Steel Material. Consult the tables for both trim and body limits.

TEMPERATURE RANGE	PRESSURE RATING
	WCC CL150
°C	Bar
-46 to -29	- - -
-29 to 38	20.0
93	17.9
149	15.9
204	13.8
232	12.8
260	11.7
316	10.7
343	9.65
371	8.62
399	6.55
427	5.52
°F	Psi
-50 to -20	- - -
-20 to 100	290
200	260
300	230
400	200
450	185
500	170
550	155
600	140
650	125
700	110
750	95
800	80

Table 4. Maximum Allowable Shutoff Pressure Drops based on Standard Trim.

Note: Do not exceed the pressure/temperature rating of the valve or mating flanges

TEMPERATURE RANGE	VALVE SIZE, NPS					
	3	4	6	8	10	12
°C	Bar					
-29 to 427	47.0	27.5	28.3	27.5	15.2	13.8
°F	Psi					
-20 to 800	680	400	410	400	220	200

1. Refer to table 3.



W9177

Figure 2. V150S Cutaway View

Slurry Vee-Ball Valve

Table 5. Design V150S Dimensions

VALVE SIZE	DESIGN V150S DIMENSIONS ⁽¹⁾										
	A	B	D	G	K	M ⁽²⁾	N ⁽²⁾	S Diameter	T	U	W
DN	mm										
80	165	80.0	235	140	130	104	98.0	19.1	152	31.8	14.2
100	194	102	214	152	140	117	98.0	19.1	152	31.8	14.2
150	230	111	214	175	164	124	112	25.4	152	31.8	14.2
200	304	184	208	220	231	195	124	31.8	235	46.0	17.5
250	385	235	208	250	261	235	132	31.8	235	46.0	17.5
300	455	291	208	300	304	270	132	38.1	235	46.0	17.5
NPS	Inch										
3	6.49	3.15	9.26	5.51	5.12	4.11	3.86	0.75	6.00	1.25	0.56
4	7.62	4.02	8.44	5.98	5.53	4.61	3.86	0.75	6.00	1.25	0.56
6	9.06	4.38	8.44	6.89	6.45	4.90	4.40	1.00	6.00	1.25	0.56
8	11.96	7.25	8.19	8.66	9.11	7.68	4.90	1.25	9.25	1.81	0.69
10	15.16	9.26	8.18	9.84	10.26	9.25	5.19	1.25	9.25	1.81	0.69
12	17.91	11.47	8.18	11.81	11.97	10.63	5.19	1.50	9.25	1.81	0.69

1. Stud length associated with clearance dimension "M" is longer than standard length specified in ASME B16.5.
2. Clearance necessary to remove flange bolts.

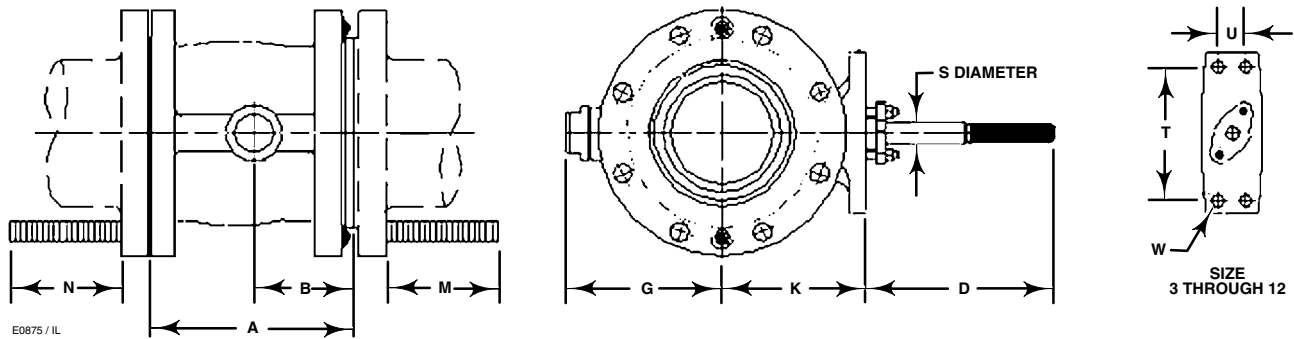

Figure 3. V150S Dimensions (see table 5)

Table 6. Design V150S Dimensions for Double D Shaft Drive

VALVE SIZE	E	S ⁽¹⁾	FLAT LENGTH	FLAT SIZE	T	U	W
DN	mm						
80	83	19.0	25.4	14.2	95	25	see below
100	83	19.0	25.4	14.2	95	25	
150	83	25.4	25.4	17.5	95	25	
200	83	31.8	25.4	20.6	133	38	
250	89	31.8	25.4	20.6	133	38	
300	89	38.1	38.1	25.4	133	38	
NPS	Inch						
3	3.25	0.75	1.0	0.56	3.75	1.0	1/2-13
4	3.25	0.75	1.0	0.56	3.75	1.0	1/2-13
6	3.25	1	1.0	0.69	3.75	1.0	1/2-13
8	3.25	1.25	1.0	0.81	5.25	1.5	5/8-11
10	3.5	1.25	1.0	0.81	5.25	1.5	5/8-11
12	3.5	1.5	1.5	1.0	5.25	1.5	5/8-11

1. This nominal valve shaft diameter is the shaft diameter through the packing box. Use this diameter when selecting Fisher actuators.

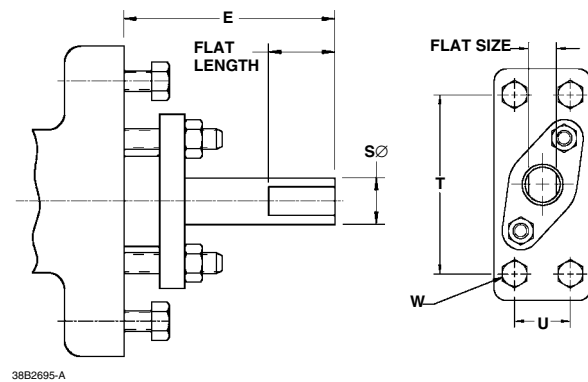

Figure 4. V150S Dimensions for Double D Shaft Drive (see table 6)

Coefficients

Table 7. Design V150S Slurry Vee-Ball® Coefficients

Reverse Flow		Modified Equal Percentage Characteristic								
Coefficients	Valve Size, NPS	Valve Rotation, Degrees								
		10	20	30	40	50	60	70	80	90
C_v	3	10	20	30	50	70	90	115	140	170
K_v		9	17	26	43	61	78	99	121	147
F_L		0.96	0.91	0.79	0.73	0.70	0.64	0.57	0.54	0.53
C_v	4	15	30	55	85	130	180	240	310	380
K_v		13	26	48	74	112	156	208	268	329
F_L		0.98	0.93	0.84	0.72	0.67	0.65	0.62	0.62	0.61
C_v	6	30	60	110	180	275	380	500	600	705
K_v		26	52	111	156	238	329	433	519	610
F_L		0.70	0.80	0.84	0.80	0.71	0.67	0.63	0.59	0.49
C_v	8	50	75	125	225	350	510	700	900	1150
K_v		43	65	108	195	303	441	606	779	995
F_L		0.77	0.83	0.87	0.80	0.73	0.66	0.61	0.58	0.58
C_v	10	75	150	250	475	725	1000	1350	1750	2200
K_v		65	130	216	411	627	865	1168	1514	1903
F_L		0.84	0.86	0.90	0.79	0.74	0.64	0.58	0.57	0.49
C_v	12	100	225	425	700	1050	1450	1900	2350	2850
K_v		87	195	368	606	908	1254	1644	2033	2465
F_L		0.71	0.81	0.80	0.73	0.69	0.62	0.59	0.55	0.50

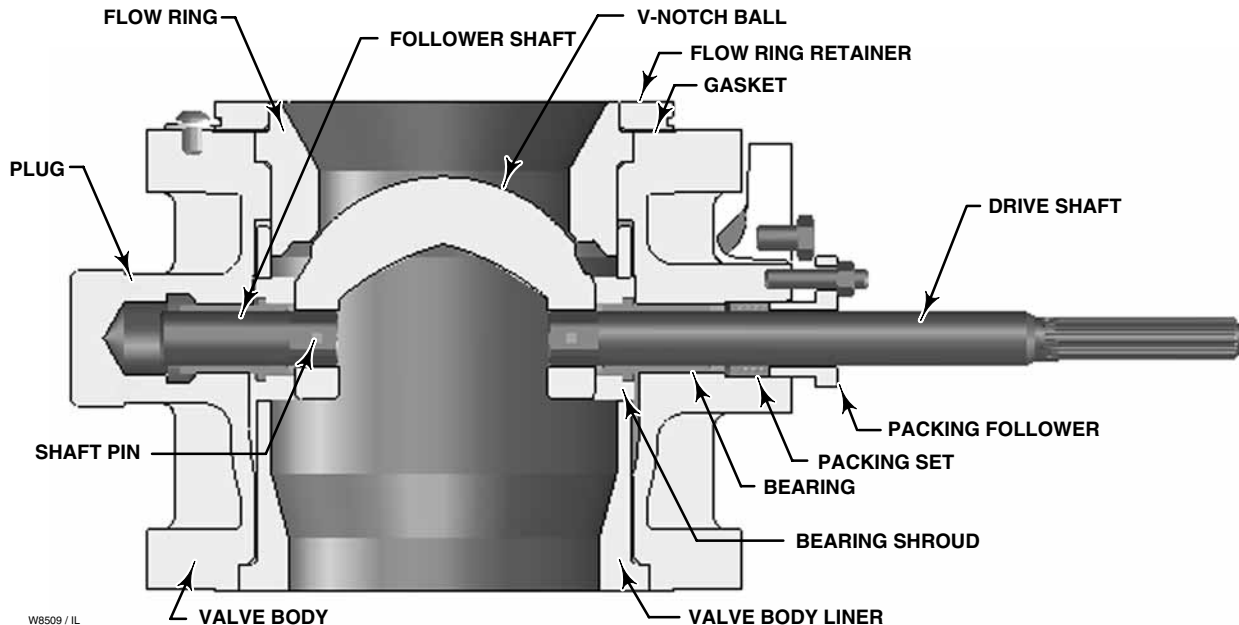

Figure 5. NPS 6 Design V150S Valve

Note

Neither Emerson, Emerson Process Management, nor any of their affiliated entities assumes responsibility for the selection, use and maintenance of any product. Responsibility for the selection, use, and maintenance of any product remains with the purchaser and end-user.

Vee-Ball and Fisher are marks owned by Fisher Controls International LLC, a member of the Emerson Process Management business division of Emerson Electric Co. Emerson Process Management, Emerson, and the Emerson logo are trademarks and service marks of Emerson Electric Co. All other marks are the property of their respective owners.

The contents of this publication are presented for informational purposes only, and while every effort has been made to ensure their accuracy, they are not to be construed as warranties or guarantees, express or implied, regarding the products or services described herein or their use or applicability. We reserve the right to modify or improve the designs or specifications of such products at any time without notice.

Neither Emerson, Emerson Process Management, nor any of their affiliated entities assumes responsibility for the selection, use and maintenance of any product. Responsibility for the selection, use and maintenance of any product remains with the purchaser and end-user.

Emerson Process Management

Marshalltown, Iowa 50158 USA

Cernay 68700 France

Sao Paulo 05424 Brazil

Singapore 128461

www.Fisher.com

