

Cavitrol® III One-, Two-, and Three-Stage Trims

Cavitrol® III trims (figures 1, 2, 3, and 4) are used for cavitating liquid applications in various globe and angle valve bodies (see tables 1, 2, and 3). (Contact your Emerson Process Management™ sales office for angle valve information.) One-stage trims are normally used where the pressure drop is below 99 bar (1440 psi); two- and three-stage trims are normally used where the pressure drop is between 99 and 207 bar (1440 and 3000 psi). The Cavitrol III trims are frequently used in pump recirculation and startup systems in the power, process, oil production, chemical refining, and other industries.

Unless otherwise noted, all NACE references are to NACE MR0175-2002.

Features

- Controls or Helps to Eliminate Cavitation Damage**—Cavitrol III trim can lengthen valve service life and reduce maintenance downtime. The shape and spacing of holes in the cage wall circumference helps prevent cavitation in a properly sized valve, effectively controlling or helping to eliminate (depending upon service conditions) cavitation damage and resulting valve failure.

- Rangeability**—Many special characterizations are available in Cavitrol III cages to match rangeability requirements of specific systems.

- Resistance to Erosion Damage**—Standard hardened trim materials provide excellent wear resistance, resulting in long trim life. The contoured valve plug seat reduces fluid separation, helps direct fluid away from trim, and helps protect against erosion damage.

- Versatility**—Available in NPS 1 to 24 globe or angle valves with weld-end or flanged-end connections.

- Easy Maintenance**—Cage-type trim allows removal and inspection of parts without taking the valve body out of the pipeline. Fine particles very seldom cause the accumulation problem associated with labyrinth-type trim.

- Efficient Operation**—A low inlet pressure to the final stage is maintained by the flow-down configuration and the successively larger flow area of each stage. At the third stage inlet (see figure 7), about 85% of the total pressure drop has already occurred and the vena contracta pressure remains above the liquid vapor pressure. This helps to prevent cavitation in a properly-sized valve.

- Trim Interchangeability**—Cavitrol III one-stage trim is interchangeable with standard trims. Quick trim changes can be made with no additional parts, such as spacers, longer bolts, and special gaskets for valve sizes greater than NPS 1.



W3708-1/1L

ONE-STAGE TRIM PARTS



W3559 / 1L

TWO- OR THREE-STAGE TRIM PARTS

Figure 1. Cavitrol® III Trims



Cavitrol III Trims

Principle of Operation

Cavitation, the formation and subsequent collapse of vapor bubbles in liquid flow streams, is a major source of damage in control valves and adjacent piping.

As liquid passes through a restriction in a control valve, the liquid velocity increases, while the liquid pressure decreases. The pressure reaches a minimum at a point called the vena contracta, and if the pressure at this point falls to or below the vapor pressure of the liquid (the pressure at which the liquid vaporizes), vapor bubbles form in the flow stream.

Downstream of the vena contracta, flow area increases, velocity decreases, and pressure increases. If this recovered pressure is sufficient to raise the pressure above the liquid vapor pressure, the vapor bubbles will collapse. The collapsing bubbles generate significant noise and vibration, and can mechanically attack pipe walls and valve components. This attack can lead to the failure of conventional valve components, particularly the valve plug and seat ring.

Cavitrol® III One-Stage Trim

The Cavitrol III one-stage trim (figures 2 and 3) can effectively eliminate cavitation damage in a properly sized and selected control valve. Each cage hole is shaped to create a small flow stream with a vena contracta pressure higher than that typically present in the flow stream of a standard cage. This higher vena contracta pressure reduces the fluid's tendency to cavitate. Each hole in a Cavitrol III one-stage cage is also designed to reduce fluid turbulence, and the holes are spaced diametrically around the cage circumference; both features dissipate fluid pressure and help to increase capacity.

Cavitrol III one-stage trim can also be used to control cavitation damage. When selected and sized for this

type of service, the radius edge on the valve plug and the diametrically opposed cage holes direct the cavitating fluid flow away from metal surfaces into the valve body cavity void. In this manner, damage from cavitating fluid flow is controlled.

Service conditions of each application govern whether cavitation damage is effectively eliminated or controlled.

Cavitrol® III Two- and Three-Stage Trims

The Cavitrol III two- and three-stage cages are concentric cylinders (or stages) (figure 4) with specially-shaped orifices. The choice of cage depends on the inlet pressure and the required pressure drop. In operation, liquid passes through the orifices in each stage, undergoing a portion of the total required pressure drop. This partial pressure drop in each stage of a properly-sized valve normally prevents the liquid pressure from falling to or below its vapor pressure, eliminating the formation of vapor bubbles.

A characterized Cavitrol III two- or three-stage trim can be specified on those applications where the pressure drop across the valve decreases with increasing valve plug travel. Characterized Cavitrol III two- or three-stage trim consists of two or three stages at the beginning of valve plug travel. Then, as the valve is required to take less pressure drop, cage sections with fewer stages are used.

Note

Neither Emerson, Emerson Process Management, nor any of their affiliated entities assumes responsibility for the selection, use and maintenance of any product. Responsibility for the selection, use, and maintenance of any product remains with the purchaser and end-user.

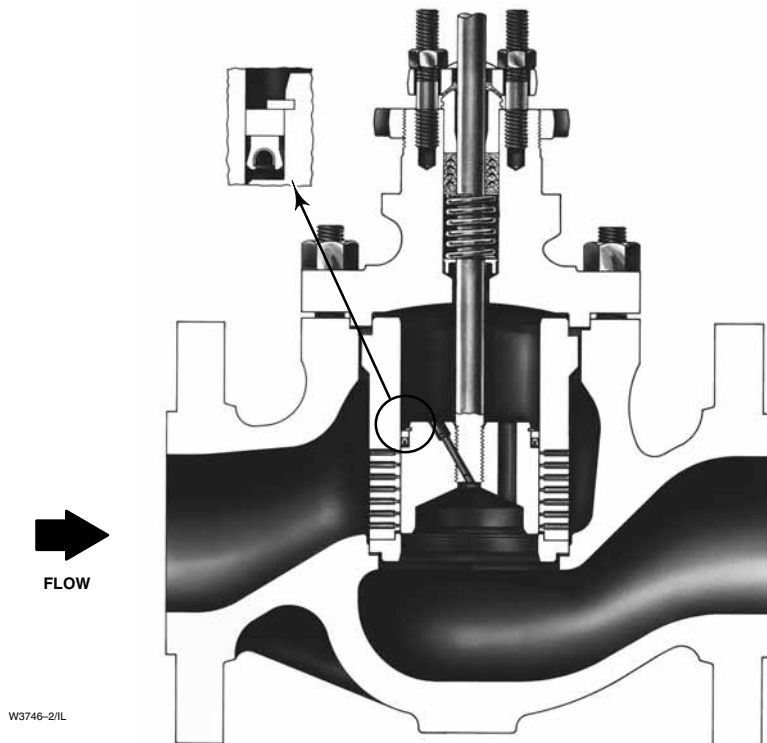

Figure 2. Sectional View of Design ET Valve with Cavitrol® III One-Stage Trim

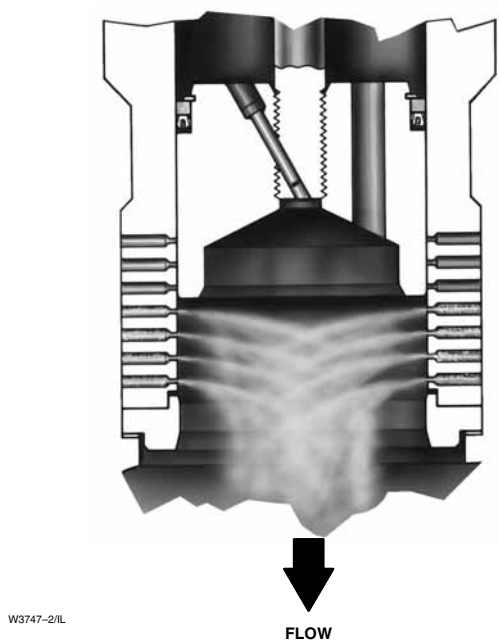

Figure 3. Operation of Cavitrol® III One-Stage Trim

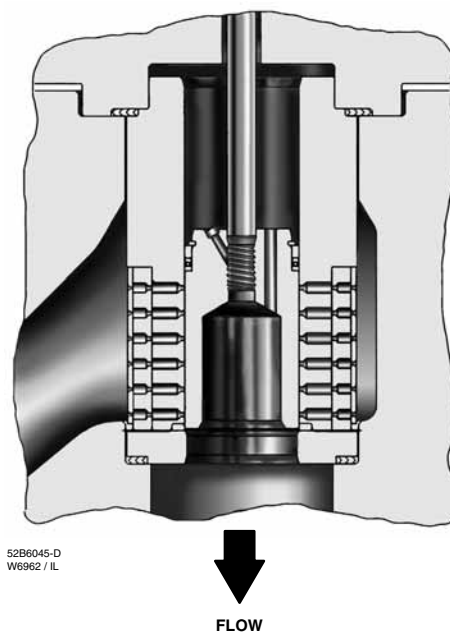

Figure 4. Design HPT with Cavitrol® III Three-Stage Trim

Cavitrol III Trims

Table 1. Additional Specifications for Cavitrol® III One-Stage Trim

VALVE RATING AND DESIGN	VALVE SIZE, NPS	PORT DIAMETER ⁽¹⁾		UNBALANCE AREA		PORT CIRCUMFERENCE		STEM DIAMETER ⁽²⁾		YOKE BOSS DIAMETER	
		mm	Inch	cm ²	Inch ²	mm	Inch	mm	Inch	mm	Inch
CL125 through 600 ET	1	33.3	1.3125	0.13	0.02	104.6	4.12	12.7	1/2	71	2-13/16
	1-1/2	47.6	1.875	0.20	0.031	149.6	5.89	12.7	1/2	71	2-13/16
	2	58.7	2.3125	0.25	0.038	184.4	7.26	12.7 19.1	1/2 3/4	71 90	2-13/16 3-9/16
	2-1/2	73.0	2.875	0.30	0.047	229.4	9.03	12.7 19.1	1/2 3/4	71 90	2-13/16 3-9/16
	3	87.3	3.4375	0.36	0.056	274.3	10.80	12.7 19.1	1/2 3/4	71 90	2-13/16 3-9/16
	4	111.1	4.375	0.50	0.077	349.0	13.74	19.1 25.4	3/4 1	90 127	3-9/16 5
	6	177.8	7	0.84	0.13	558.5	21.99	25.4 or 31.8	1 or 1-1/4	127	5
	8	203.2	8	0.97	0.15	638.3	25.13	25.4 or 31.8	1 or 1-1/4	127	5
CL600 EWT	4x2	58.7	2.3125	0.25	0.038	184.4	7.26	12.7 19.1	1/2 3/4	71 90	2-13/16 3-9/16
	6x4 or 8x4	111.1	4.375	0.50	0.077	349.0	13.74	19.1 25.4	3/4 1	90 127	3-9/16 5
	8x6 or 12x6	177.8	7	0.84	0.13	558.5	21.99	25.4 or 31.8	1 or 1-1/4	127	5
	10x8 or 12x8	203.2	8	0.97	0.15	638.3	25.13	25.4 or 31.8	1 or 1-1/4	127	5
CL150 through 600 EUT-2	12	279.4	11	3.16	0.49	877.3	34.54	31.8	1-1/4	127	5
	16	374.7	14.75	4.19	0.65	1177	46.32	31.8	1-1/4	127	5
CL150 through 600 EWT-2	16x12	279.4	11	3.16	0.49	877.3	34.54	31.8	1-1/4	127	5
	20x16	374.7	14.75	4.19	0.65	1177	46.32	31.8	1-1/4	127	5
	24x16	374.7	14.75	4.19	0.65	1177	46.32	31.8	1-1/4	127	5
	24x20	463.6	18.25	5.29	0.81	1456	57.31	31.8	1-1/4	127	5

1. Same as Design ET or EWT port diameter. Also listed in valve bulletin.

2. When two stem diameters are shown for a particular valve size, the smaller stem diameter is standard and the larger stem diameter is optional.

Table 2. Valve Travels and Flow Coefficients (Cavitrol® III One-Stage Trim)

VALVE RATING AND DESIGN	VALVE SIZE, NPS	STANDARD				OPTIONAL FOR DESIGN ET AND EWT DUE TO OVERTRAVEL			F _L at Maximum Travel
		Travel		Min ⁽¹⁾	Max	Maximum Travel		Max C _v ⁽²⁾	
		mm	Inch	C _v	C _v	mm	Inch		
CL125 through 600 ET	1	19	0.75	1.9	12.2	25	1	15.5	0.90
	1-1/2	19	0.75	2.5	19.4	22	0.875	22.5	0.93
	2	29	1.125	3.9	36.1	---	---	---	0.93
	2-1/2	38	1.5	4.2	64.4	---	---	---	0.91
	3	38	1.5	4.6	81.5	41	1.625	86.7	0.89
	4	51	2	5.2	148	54	2.125	151	0.90
	6	51	2	10	238	57	2.25	259	0.91
	8	76	3	15	408	86	3.375	439	0.94
CL600 EWT	4x2	29	1.125	3.9	43.6	---	---	---	0.91
	6x4	51	2	5.2	162	54	2.125	169	0.95
	8x4	51	2	5.2	165	54	2.125	171	0.95
	8x6	51	2	10	267	57	2.25	293	0.93
	12x6	51	2	10	280	57	2.25	305	0.93
	10x8	76	3	15	418	76	3.375	455	0.92
	12x8	76	3	15	433	86	3.375	487	0.90
CL150 through 600 EWT-2	12	203	8	40	1160	---	---	---	0.91
		226	8.88	40	1210	---	---	---	0.91
	16	203	8	46	1790	---	---	---	0.91
		276	10.88	46	2120	---	---	---	0.91
CL150 through 600 EWT-2	16x12	203	8	40	1330	---	---	---	0.91
		302	11.88	40	1630	---	---	---	0.91
	20x16	276	10.88	46	2390	---	---	---	0.91
		378	14.88	46	2800	---	---	---	0.91
	24x16	276	10.88	46	2390	---	---	---	0.91
		378	14.88	46	2800	---	---	---	0.91
	24x20	429	16.88	46	2940	---	---	---	0.91
		276	10.88	56	3160	---	---	---	0.91
		378	14.88	56	3810	---	---	---	0.91
		429	16.88	56	4050	---	---	---	0.91

1. Valves should not be required to throttle at a Cv less than the minimum Cv for an extended period of time. Erosion damage to the valve seats may result.
 2. Minimum Cv for the Optional category is the same as the minimum Cv in the Standard category.

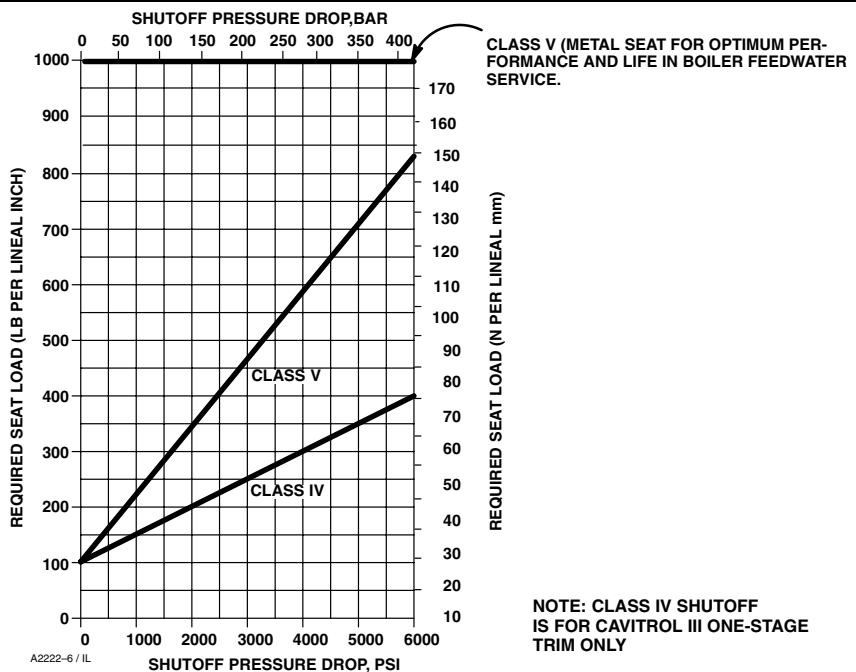
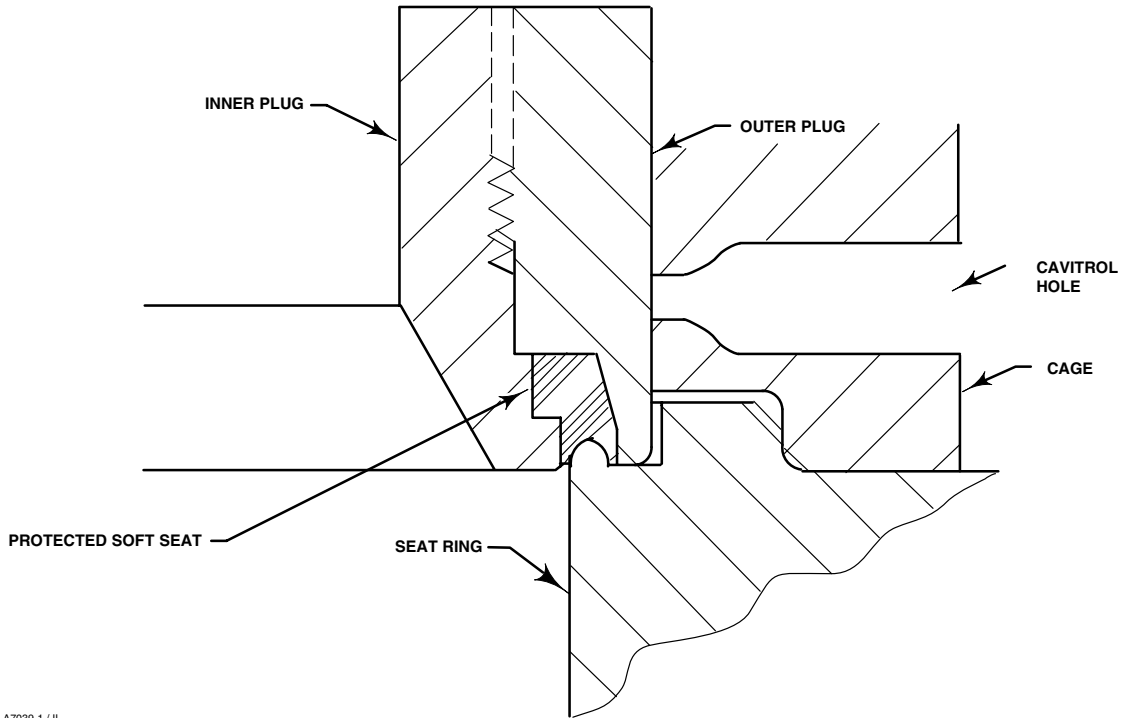
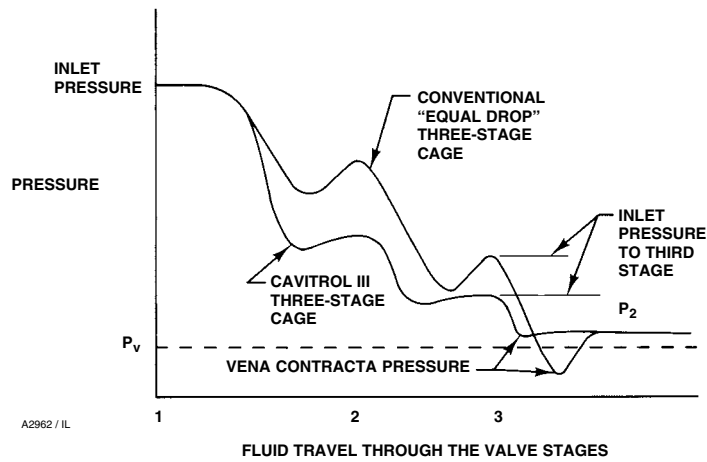

Figure 5. Required Seat Force for Class IV and V Shutoff Classification



A7039-1 / IL

Figure 6. Detail of TSO (Tight Shutoff Trim) Protected Soft Seat



A2962 / IL

Figure 7. Pressure Drop Patterns (Cavitrol® III Three-Stage Trim)

Table 3. Standard Cavitrol® III Trim (Linear Characteristic for Cavitrol III Two-Stage Trims)^(1, 2)

VALVE BODY RATING AND DESIGN	VALVE SIZE, NPS	Port Diameter		Travel		Min ⁽³⁾ C _v	Max C _v	UNBALANCE AREA		F _L at Maximum Travel
		mm	Inch	mm	Inch			cm ²	Inch ²	
CL600 ET	1	25.4	1	25	1	0.28	5.8	0.13	0.02	0.98
	1-1/2	33.3	1.3125	38	1.5	0.44	9.4	0.13	0.02	0.98
	2	47.6	1.875	51	2	0.92	21	0.20	0.031	0.98
	2-1/2	58.7	2.3125	64	2.5	1.1	33	0.25	0.038	0.98
	3	73.0	2.875	76	3	1.2	49	0.30	0.047	0.98
	4	73.0	2.875	102	4	1.9	69	0.30	0.047	0.98
	6	136.5	5.375	102	4	3.0	144	0.65	0.10	0.98
	8	177.8	7	152	6	7.0	265	0.84	0.13	0.98
CL600 ^(4, 6) EWT	4 x 2	47.6	1.875	51	2	0.92	22	0.20	0.031	0.98
	6 x 4	73.0	2.875	102	4	1.9	71	0.30	0.047	0.98
	8 x 4	73.0	2.875	102	4	1.9	81.5	0.30	0.047	0.98
	8 x 6	136.5	5.375	127	5	3.0	178	0.65	0.10	0.98
	12 x 6	136.5	5.375	152	6	3.0	208	0.65	0.10	0.98
	12 x 8	177.8	7	152	6	7.0	272	0.84	0.13	0.98
CL2500 EHT	3, 4 x 3	47.6	1.875	64	2.5	0.61	24.1	0.20	0.031	0.98
	4, 6 x 4	73	2.875	70	2.75	0.91	43.9	0.30	0.047	0.98
	6, 8 x 6	111.1	4.375	95	3.75	1.5	75.8	0.50	0.077	0.98
CL900 and 1500 HPAS and HPAT	1	22.2	0.875 ⁽⁵⁾	38	1.5	0.36	7.39	3.88	0.601	0.98
	2	44.5	1.75	51	2	0.58	14.0	0.19	0.029	0.98
CL900 and 1500 HPS and HPT	1	22.2	0.875 ⁽⁵⁾	38	1.5	0.36	7.39	3.88	0.601	0.98
	2	44.5	1.75	51	2	0.58	14.0	0.19	0.029	0.98
	3	63.5	2.5	64	2.5	0.73	34.4	0.26	0.041	0.98
	4	87.3	3.4375	76	3	0.90	58.1	0.31	0.056	0.98
	6	133.4	5.25	102	4	1.72	123	0.59	0.092	0.98

1. Characterized cages are available. Consult your Emerson Process Management sales office for information.
 2. Cv as low as 0.04 is available. Consult your Emerson Process Management sales office for information.
 3. Valves should not be required to throttle at a Cv less than the minimum Cv for an extended period of time. Erosion damage to the valve seats may result.
 4. Values for CL900 NPS 8 x 6 and 12 x 8 EWT available in two-stage trim same as CL600 NPS 8 x 6 and 12 x 8 EWT.
 5. Cavitrol III trim in the CL1500 and 2500, NPS 1, two-stage and in the NPS 2, three-stage valve uses unbalanced valve plugs. These sizes and constructions are Design HPS/HPAS valves; other valves in this section of the table are Design HPT/HPAT valves.
 6. For larger sizes, consult your Emerson Process Management sales office.

Table 4. Standard Cavitrol® III Trim (Linear Characteristic for Cavitrol III Three-Stage Trims)^(1, 2)

VALVE BODY RATING AND DESIGN	VALVE SIZE, NPS	Port Diameter		Travel		Min ⁽³⁾ C _v	Max C _v	UNBALANCE AREA		F _L at Maximum Travel
		mm	Inch	mm	Inch			cm ²	Inch ²	
CL2500 EHT	3, 4 x 3	33.3	1.3125	64	2.5	0.73	13.1	0.13	0.02	0.99
	4, 6 x 4	58.7	2.3125	70	2.75	1.0	20.8	0.25	0.038	0.99
	6, 8 x 6	111.1	4.375	95	3.75	2.8	66.7	0.50	0.077	0.99
CL900 and 1500 HPAS and HPAT	1	---	---	---	---	---	---	---	---	---
	2	25.4	1 ⁽⁴⁾	51	2	0.59	6.73	5.06	0.785	0.99
CL900 and 1500 HPS and HPT	1	---	---	---	---	---	---	---	---	---
	2	25.4	1 ⁽⁴⁾	51	2	0.59	6.73	5.06	0.785	0.99
	3	47.6	1.875	38	1.5	1.20	16.5	0.20	0.031	0.99
	4	73	2.875	76	3	1.70	27.8	0.30	0.047	0.99
	6	115.9	4.5625	102	4	3.10	65.0	0.52	0.080	0.99

1. Characterized cages are available. Consult your Emerson Process Management sales office for information.
 2. Cv as low as 0.04 is available. Consult your Emerson Process Management sales office for information.
 3. Valves should not be required to throttle at a Cv less than the minimum Cv for an extended period of time. Erosion damage to the valve seats may result.
 4. Cavitrol III trim in the CL1500 and 2500, NPS 1, two-stage and in the NPS 2, three-stage valve uses unbalanced valve plugs. These sizes and constructions are Design HPS/HPAS valves; other valves in this section of the table are Design HPT/HPAT valves.

Cavitrol III Trims

Table 5. Trim Material and Temperature Limit

VALVE DESIGN	VALVE RATING	TRIM DESIGNATION	VALVE PLUG	CAGE	SEAT RING	VALVE STEM	BONNET SPACER ^(6, 7)	MAXIMUM TEMPERATURE	
								°C	°F
ET	CL600	76	Heat-treated S42000 (420 SST)	S17400 (17-4PH SST) with H900 heat-treat condition S31600 ⁽¹⁾	S17400 stainless steel with H900 heat-treat condition	S31600 stainless steel (316 SST)	S31600 stainless steel (316 SST)	See figure 8	See figure 8
EWT	CL600 and 900	76	Heat-treated S42000	S17400 stainless steel with H900 heat-treat condition S31600 ⁽¹⁾	S17400 stainless steel with H900 heat-treat condition	S31600 stainless steel	S31600 stainless steel		
EHT	CL2500	58	Heat-treated S44004 (440C SST)	CB7CU-1 (17-4PH SST) with H1075 heat-treat condition	S44004 S17400 H1150 chrome coat ⁽²⁾	S31600 stainless steel	None		
		59	S31600 with CoCr-A seat and guide	CB7CU-1 with H1150 heat-treat condition	CoCr-A S17400 H1150 chrome coat ⁽²⁾	S31600 stainless steel	None		
HPS, HPAS, HPT, and HPAT	CL900 and 1500	205A	Heat-treated S44004	S17400 stainless steel with H1075 heat-treat condition	S44004	S20910 stainless steel	Same as body / bonnet material	232 ⁽⁵⁾	450 ⁽⁵⁾
		205B	Heat-treated S44004	S17400 stainless steel with H1075 heat-treat condition	S44004	S31600 stainless steel	Same as body / bonnet material		
		206 (NACE) ^(3,4)	S31600 with CoCr-A seat and guide	S17400 stainless steel with double H1150 heat-treat condition	S31600/CoCr-A	S20910 stainless steel	Same as body / bonnet material		

1. Second material shown is cage retainer.
2. Second material shown is seat ring retainer.
3. If using valve body/trim combinations other than those listed, consult your Emerson Process Management sales office.
4. NACE MR0175-2002.
5. NPS 1 2 stage and NPS 2 3 stage HPS can be used at temperatures up to 343°C (650°F).
6. Bonnet spacer is not used with E and EW series one-stage trims or with EH Series valves.
7. Bonnet spacer is used only with 2-stage trims in NPS 2 HPT/HPAT valves.

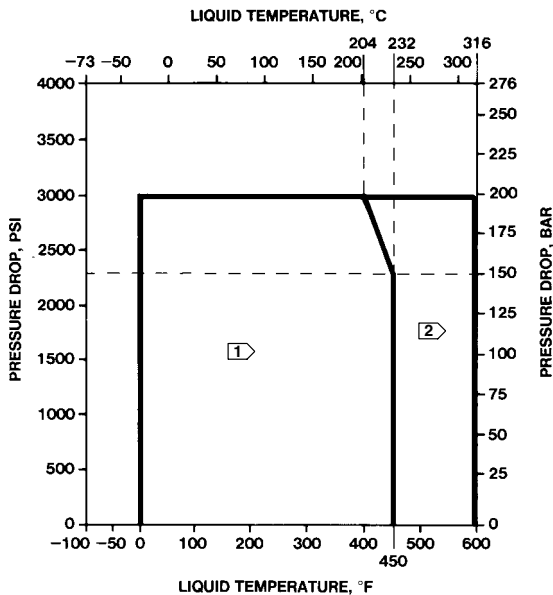

NOTES:

- 1. FOR BOTH GLASS-FILLED AND GRAPHITE-FILLED PTFE AND N10276 SEAL RING
- 2. FOR PEEK ANTI-EXTRUSION RING WITH GRAPHITE-FILLED PTFE AND N10276 SEAL RING
- 3. DO NOT EXCEED 143 BAR (2160 PSI) WITH TWO-STAGE CAVITROL III CAGE.
- 4. PEEK REQUIRED FOR ALL BOILER FEEDWATER APPLICATIONS.
- 5. FOR STAINLESS STEEL PRESSURE BOUNDARY MATERIALS, CONTACT YOUR EMERSON PROCESS MANAGEMENT SALES OFFICE.

A2963-1 / IL

Figure 8. Pressure Drop/Temperature Capabilities with Seal Ring (Cavitrol® III Two- and Three-Stage Trims)

Installation

Valve bodies with Cavitrol III trim must be installed so that the flow direction is in through the cage openings and out through the seat ring. This will be indicated by an arrow on the valve body.

Exterior dimensions for Design ET and EWT valve bodies with Cavitrol III one-stage trim and Design EHT valve bodies with Cavitrol III trims do not change from their standard trim constructions. For Design ET and EWT valve bodies with Cavitrol III two-stage trims, see figure 9 and tables 6 and 7 for details of dimensions that change from standard. For all other dimensions, refer to the appropriate valve body bulletin.

Ordering Information

When ordering, specify:

Application Information

1. Process liquid—State particle size and type of entrained impurities, if any.
2. Specific gravity of liquid
3. Temperature and vapor pressure of liquid
4. Critical pressure
5. Range of flowing inlet pressures
6. Pressure drops
 - a. Range of flowing pressure drops
 - b. Maximum at shutoff
7. Flow rates
 - a. Minimum controlled flow
 - b. Normal flow
 - c. Maximum flow
8. Required C_v
9. Line size and schedule

Valve Body Information

To determine what information is needed for ordering the valve body and trim, refer to the Specifications section. Review the description at the right of each specification or in the referenced tables, figures, and bulletins, and indicate the desired choice wherever a selection is to be made. Always specify the body design being ordered as selected from table 1 or 3.

Actuator and Accessory Information

Select the specific actuator and accessories from the appropriate bulletins. Typically piston actuators must be used where the required valve plug travel is greater than 102 mm (4 inches). Typically diaphragm actuators may be used for 102 mm (4 inches) or less required travel. Specify any additional ordering information as required from actuator or accessory bulletins.

If operating below minimum published C_v s (see tables 2, 3, and 4), added trim reliability may be obtained through use of low travel cutoff features available with DVC6000 Series digital valve controllers.

Table 6. Non-Standard Dimensions (Cavitrol® III Two-Stage Trims Only)

DESIGN ET CL600						
Valve Size, NPS	Yoke Boss Diameter		Stem Diameter		Dimension D	
	mm	Inch	mm	Inch	mm	Inch
1	71	2-13/16	12.7	1/2	184	7.25
1-1/2	54	2-1/8	9.5	3/8	155	6.12
	71	2-13/16	12.7	1/2	178	7.00
2	71	2-13/16	12.7	1/2	202	7.94
	90	3-9/16	19.1	3/4	198	7.81
2-1/2	71	2-13/16	12.7	1/2	230	9.06
	90	3-9/16	19.1	3/4	227	8.94
3	71	2-13/16	12.7	1/2	260	10.25
	90	3-9/16	19.1	3/4	257	10.12
4	90	3-9/16	19.1	3/4	308	12.12
	127	5	25.4	1	379	14.94
6(1)	90	3-9/16	19.1	3/4	337	13.25
	127	5	25.4 or 31.8	1 or 1-1/4	406	16.00
8	90	3-9/16	19.1	3/4	511	20.12
	127	5	25.4 or 31.8	1 or 1-1/4	586	23.06

1. 102 mm (4 inch) travel construction. D dimension does not change for 51 mm (2 inch) travel construction.

Table 7. Non-Standard Dimensions (Cavitrol® III Two-Stage Trims Only)

DESIGN EWT CL600(1)						
Valve Size, NPS	Yoke Boss Diameter		Stem Diameter		Dimension D	
	mm	Inch	mm	Inch	mm	Inch
4 x 2	71	2-13/16	12.7	1/2	252	9.94
	90	3-9/16	19.1	3/4	249	9.81
6 x 4	71	2-13/16	12.7	1/2	346	13.62
	90	3-9/16	19.1	3/4	343	13.50
	127	5	25.4 or 31.8	1 or 1-1/4	389	15.32
8 x 4	71	2-13/16	12.7	1/2	348	13.69
	90	3-9/16	19.1	3/4	344	13.56
	127	5	25.4 or 31.8	1 or 1-1/4	391	15.38
8 x 6(2)	90	3-9/16	19.1	3/4	402	15.82
	127	5	25.4 or 31.8	1 or 1-1/4	446	17.56
12 x 6(2)	90	3-9/16	19.1	3/4	478	18.82
	127	5	25.4 or 31.8	1 or 1-1/4	522	20.56
10 x 8	90	3-9/16	19.1	3/4	511	20.12
	127	5	25.4 or 31.8	1 or 1-1/4	586	23.06
12 x 8	90	3-9/16	19.1	3/4	559	22.00
	127	5	25.4 or 31.8	1 or 1-1/4	613	24.12

1. CL600 and CL900 NPS 8 x 6 and 12 x 8 are the same.
2. Long travel construction. D dimension does not change for 51 mm (2 inch) travel construction.

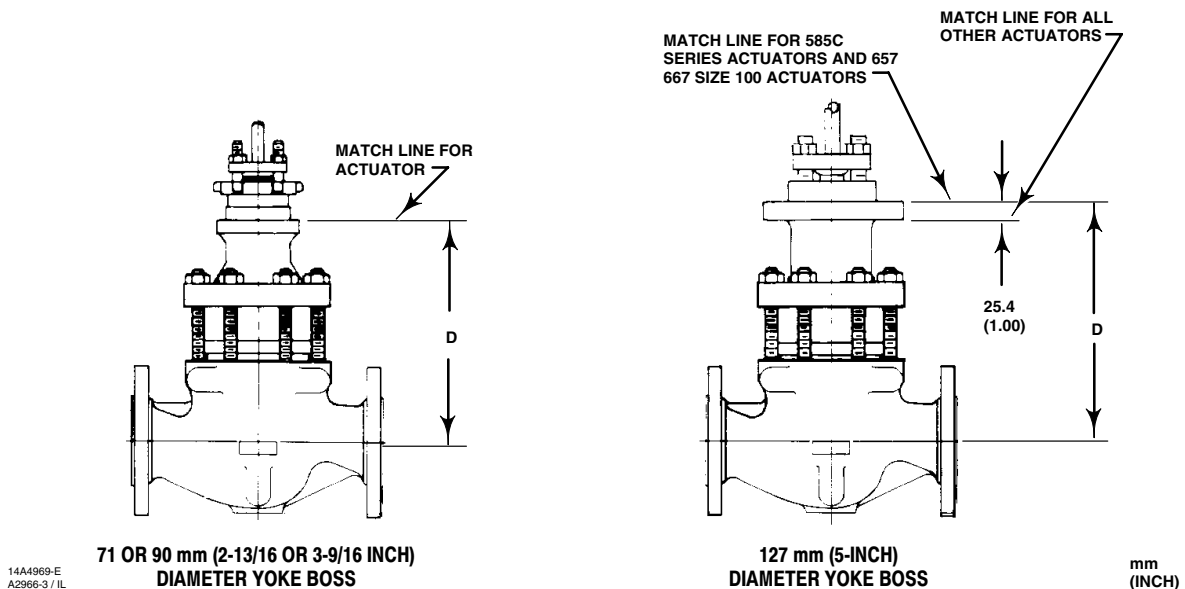

Figure 9. Non-Standard Dimensions (Cavitrol® III Two-Stage Trims Only) (also see tables 6 and 7)

Specifications

Available Valves

One-stage: See table 1.
Two- and three-stage Cavitrol III: See table 3.
Two- and three-stage Characterized Cavitrol III: Consult your Emerson Process Management sales office

End Connection Styles

Refer to appropriate valve bulletin

Shutoff Classification

Class IV (standard for one-stage trim only):
 [0.01% of valve capacity at full travel tested with air at 3.4 bar (50 psid)] per ANSI/FCI 70-2 and IEC 60534-4
Class V (standard for two- and three-stage trims, optional for one-stage trim):
 [5x10⁻¹²m³/sec/bar/mm of port diameter (0.0005 mL/min/psid/in) of water at service pressure drop] per ANSI/FCI 70-2 and IEC 60534-4
TSO (Tight Shutoff Trim) (optional for one-, two-, and three-stage trims): Valves with TSO trim are factory tested to a more stringent Emerson test requirement of no leakage at time of shipment using ANSI/FCI Class V procedures. Consult your Emerson Process Management sales office for additional information. See figure 6

Maximum Inlet Pressures⁽¹⁾

Consistent with applicable ASME B16.34 pressure/temperature ratings as shown in tables 1 and 3 up to 232°C (450°F)

Maximum Pressure Drop⁽¹⁾

One-stage: 99.3 bar (1440 psi) but do not exceed the maximum pressure and temperature for the class rating of the valve body material used
Two-stage: 149 bar (2160 psi), but do not exceed maximum allowable inlet pressure
Three-stage: 207 bar (3000 psi), but do not exceed maximum allowable inlet pressure
 Pressure drops are valve size and trim stage dependent. For additional Cavitrol trim application guidelines, contact your Emerson Process Management sales office.

Construction Materials

See table 5

Temperature Capabilities⁽¹⁾

One-stage: -29 to 232°C (-20 to 450°F)
Two- and three-stage: See table 5 and figure 8

Flow Characteristic

Standard Cage: Linear
Characterized Cage: Consult your Emerson Process Management sales office

Flow Direction

Flow down (in through cage openings and out through seat ring as shown in figure 3)

Flow Coefficients⁽²⁾

Values given in tables 2 and 3; also see Fisher® Catalog 12

- continued -

Specifications (continued)

Valve Recovery Coefficients⁽²⁾

F_L of One-Stage Cage: See table 2.

F_L of Two-Stage Cage: 0.98

F_L of Three-Stage Cage: 0.99

These values define the maximum allowable pressure drop that is effective in producing flow as shown in the following equation:

$$\Delta P_{\text{allowable}} = F_L [P_{1(\text{flowing})} - r_c P_v]$$

Where

$\Delta P_{\text{allowable}}$ = maximum allowable pressure drop that is effective in producing flow, bar (psi)

$P_{1(\text{flowing})}$ = flowing inlet pressure, bar, absolute (psia)

r_c = critical pressure ratio from Catalog 12

P_v = vapor pressure of liquid at inlet temperature, bar, absolute (psia)

Port Diameters and Circumferences

See tables 1 and 3

Maximum Valve Plug Travel

See tables 2 and 3

Minimum Seating Force

Refer to figure 5 to determine minimum seat load per unit of port circumference; multiply that value by the port circumference from table 1 or Catalog 14

Valve Plug Stem and Yoke Boss Diameters

See tables 1, 6, and 7 and figure 9

Valve Plug Unbalance Area

See tables 1, 3, and 4

Noise Level

Use Emerson Process Management liquid noise prediction methods available in the Emerson Process Management sizing program

Options

■ Cage with Special Characterization or ■ Valve Plug for applications over 232°C (450°F)

1. The pressure/temperature limits in this bulletin and any applicable standard or code limitation for valve should not be exceeded.
2. For standard linear cage. Consult your Emerson Process Management sales office for flow coefficients and valve recovery coefficients of cages with optional characteristics.

Note

Neither Emerson, Emerson Process Management, nor any of their affiliated entities assumes responsibility for the selection, use and maintenance of any product. Responsibility for the selection, use, and maintenance of any product remains with the purchaser and end-user.

Cavitrol and Fisher are marks owned by Fisher Controls International LLC, a member of the Emerson Process Management business division of Emerson Electric Co. Emerson Process Management, Emerson, and the Emerson logo are trademarks and service marks of Emerson Electric Co. All other marks are the property of their respective owners.

The contents of this publication are presented for informational purposes only, and while every effort has been made to ensure their accuracy, they are not to be construed as warranties or guarantees, express or implied, regarding the products or services described herein or their use or applicability. We reserve the right to modify or improve the designs or specifications of such products at any time without notice.

Neither Emerson, Emerson Process Management, nor any of their affiliated entities assumes responsibility for the selection, use and maintenance of any product. Responsibility for the selection, use and maintenance of any product remains with the purchaser and end-user.

Emerson Process Management

Marshalltown, Iowa 50158 USA

Cernay 68700 France

Sao Paulo 05424 Brazil

Singapore 128461

www.Fisher.com

