

Design D2 FloPro Control Valve

The Design D2 FloPro control valve (figure 1) is a compact, rugged valve designed for on-off control. This valve is ideal for use as a dump valve on gas separators and scrubbers. It is also well suited for other high pressure applications in natural gas production, compression, and processing. The Design D2 FloPro valve has threaded end connections and is available in an NPS 1 globe style valve body, see figure 1.

Features

- **Field-Selectable Flow Rates**—The FloPro feature allows easy setting of 0.25, 0.375, and 0.5 inch flow rates, eliminating the need for more than one port size. See figure 3.

- **Trim Options**—The valve plug and seat ring are available in S17400 double H1150, or solid R30006 (Alloy 6) for erosive service.

- **ENVIRO-SEAL® D2 Packing System**—The ENVIRO-SEAL D2 packing system provides an improved stem seal to prevent the loss of valuable or hazardous process fluids or gases. It features live-loading, providing reduced packing maintenance.

- **NACE MR0175/ISO 15156 Service-Ready**—Sour service trim is the standard construction for the D2 FloPro control valve. The materials of construction meet the metallurgical requirements of NACE MR0175/ISO 15156. Environmental limits may apply.



W9235-1

Figure 1. Design D2 FloPro Control Valve



Product Bulletin

51.2:D2
February 2008

D2 FloPro Valve

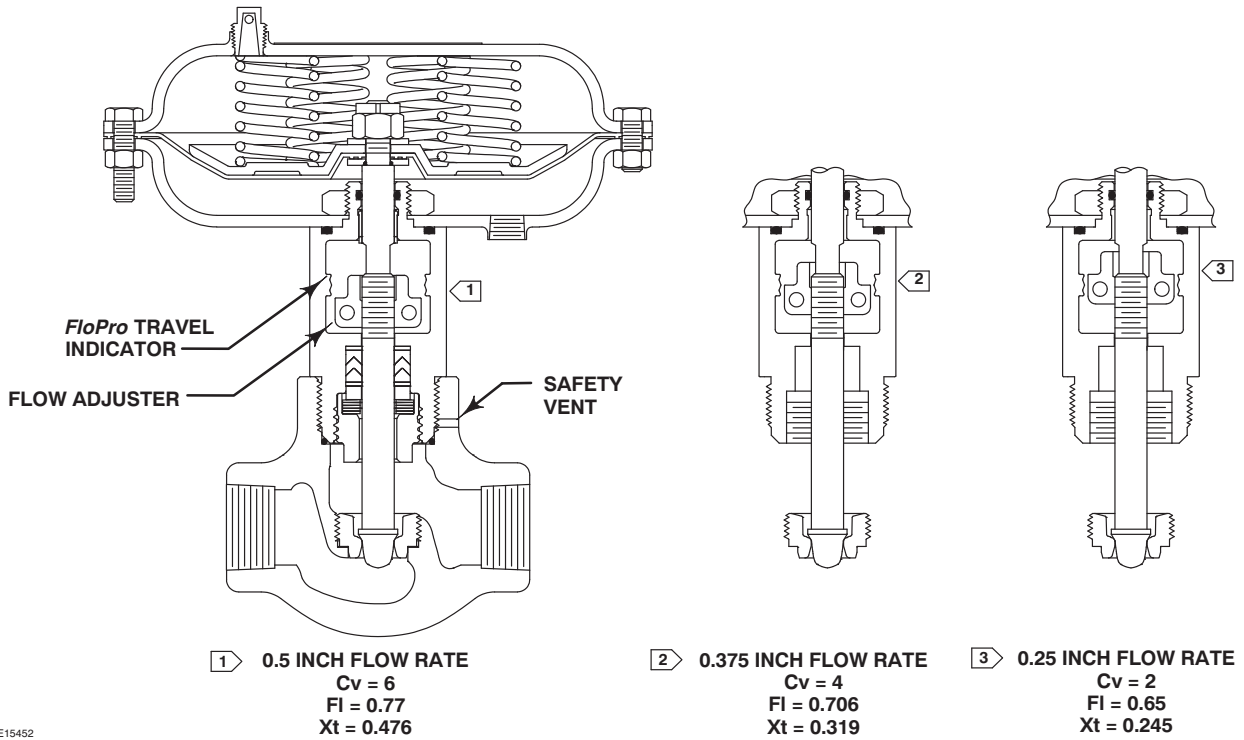

GE15452

Figure 3. Flow Rate Adjustments

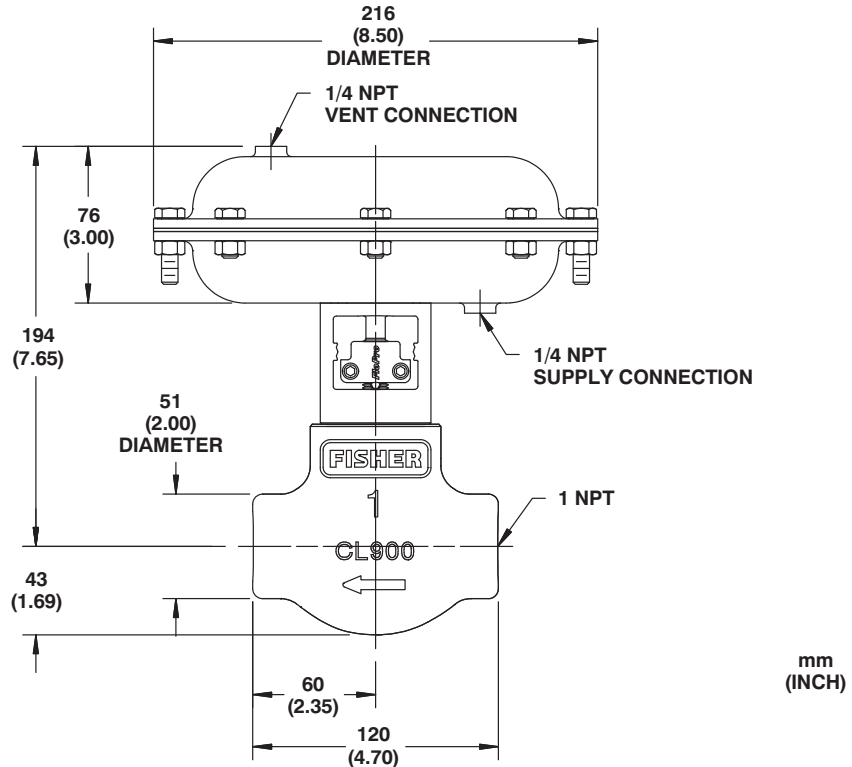

19B8490-B
E0783

Figure 4. Design D2 Globe Valve Dimensions (Air-to-Open Configuration Shown)

D2 FloPro Valve

Specifications

<p>Valve Assembly Pressure Class⁽¹⁾ ASME B16.34 CL900</p> <p>Temperature Range⁽¹⁾ 155 bar from -46 to 93°C, and 150 bar at 149°C. (2250 psig from -50 to 200°F, and 2185 psig at 300°F)</p> <p>Maximum Allowable Pressure Drop⁽¹⁾ Flow Down⁽²⁾ <i>Maximum Inlet Pressure:</i> 155 bar (2250 psig) <i>Maximum Outlet Pressure:</i> 103 bar (1500 psig) Flow Up <i>Maximum Inlet Pressure:</i> 103 bar (1500 psig) <i>Maximum Outlet Pressure:</i> 103 bar (1500 psig)</p> <p>Shutoff Classification Class IV ANSI/FCI 70-2 and IEC 60534-4</p> <p>Construction Materials Valve Body and Bonnet: ASME SA 352 LCC Valve Plug and Seat: ■ R30006 (Alloy 6) or ■ S17400 double H1150 Valve Stem: S31600 O-Rings: HNBR (Hydrogenated Nitrile) Packing: PTFE/Carbon PTFE Packing Springs: N07718 Stem Bushing: PPS (polyphenylene sulfide) Actuator Diaphragm: Nitrile/Polyester Actuator Springs: Zinc-plated steel</p> <p>Flow Characteristic <i>FloPro</i> Characterized</p> <p>Flow Coefficients See figure 3</p> <p>Port Diameter 13 mm (0.5 inch)</p>	<p>Maximum Travel 13 mm (0.5 inch)</p> <p>Valve Travel Indications See figure 3</p> <p>Approximate Weight 7.7 kg (17 lb)</p> <p>Dimensions See figure 4</p> <p>Material Temperature Capabilities Valve Body Assembly: -46 to 149°C (-50 to 300°F) Actuator Assembly: -46 to 93°C (-50 to 200°F)</p> <p>Bonnet/Body Connection Screwed with leakoff bleed</p> <p>Standard Actuator Configuration The <i>D2 FloPro</i> actuator is an on-off spring-and-diaphragm. Globe Valve Body: Supplied as either Air-to-Open or Air-to-Close.</p> <p>Maximum Actuator Casing Pressure 2.8 bar (40 psig)</p> <p>Minimum Required Actuator Casing Pressure 2.1 to 2.4 bar (30 to 35 psig)</p> <p>Actuator Diaphragm Effective Area 194 cm² (30 square inches)</p> <p>Actuator Pressure Connections 1/4 NPT internal; see figure 4 for locations</p>
---	---

1. The pressure or temperature limits in the referenced tables and any applicable ASME code limitations should not be exceeded.
2. Standard flow direction.

ENVIRO-SEAL and Fisher are marks owned by Fisher Controls International LLC, a member of the Emerson Process Management business division of Emerson Electric Co. Emerson Process Management, Emerson, and the Emerson logo are trademarks and service marks of Emerson Electric Co. All other marks are the property of their respective owners. This product may be covered by one or more of the following patents: 5,129,625; 5,131,666; 5,056,757; 5,230,498; 5,299,812; 6,698,449 B2; 6,695,000 B2; 6,769,666; and 6,866,244 or under pending patents.

The contents of this publication are presented for informational purposes only, and while every effort has been made to ensure their accuracy, they are not to be construed as warranties or guarantees, express or implied, regarding the products or services described herein or their use or applicability. We reserve the right to modify or improve the designs or specifications of such products at any time without notice.

Neither Emerson, Emerson Process Management, nor any of their affiliated entities assumes responsibility for the selection, use and maintenance of any product. Responsibility for the selection, use and maintenance of any product remains with the purchaser and end-user.

Emerson Process Management

Marshalltown, Iowa 50158 USA
Cernay 68700 France
Sao Paulo 05424 Brazil
Singapore 128461

www.Fisher.com

