

Type 9500 Butterfly Control Valve

The Type 9500 butterfly valve (figure 1 or 2) is a fully lined valve for use with corrosive fluids and where tight shutoff is required. The nitrile or PTFE liner totally isolates the valve body and shaft from the process fluid and maintains excellent shutoff at pressure drops to 15.2 bar (220 psi), and temperatures to 121°C (250°F).

The 9500 valve is available in 2- through 12-inch sizes and is compatible with ASME B16.1 Class 125B, with ASME B16.34 Class 150 and 300, or with DIN flanges. These valves are furnished with splined shafts for use with power actuators (figure 1 or 2), with a Type 1077 manual actuator, or with a Type 1078 declutchable manual actuator (see figure 3).

Note

Neither Emerson®, Emerson Process Management™, Fisher®, nor any of their affiliated entities assumes responsibility for the selection, use and maintenance of any product. Responsibility for the selection, use, and maintenance of any product remains with the purchaser and end-user.



W9224-1

Figure 1. Type 9500 Valve with Type 1052 Actuator and DVC6020 Digital Valve Controller



W4082/L

Figure 2. Type 9500 Valve with Type 1066SR Actuator



Specifications

Valve Sizes

■ 2, ■ 3, ■ 4, ■ 6, ■ 8, ■ 10, or ■ 12-inch

Valve Style

Flangeless (wafer-type) valve to be installed between two pipe flanges

End Connection Styles

Flangeless (wafer-style) valve mates with Class 125 flat-face flanges per ASME B16.1, Class 150 and 300 raised-face flanges per ASME B16.34, or DIN flanges as shown in table 2

Maximum Allowable Inlet Pressure⁽¹⁾

Maximum material temperature capabilities are limited as shown in table 3. The material maximum allowable shutoff or flowing pressure drop limits are shown in tables 1 and 4. Valve bodies are consistent with applicable pressure/temperature ratings for ■ Class 125B per ASME B16.1, or ■ Class 150 and 300 per ASME B16.34.

Vacuum Service

Valves suitable are for vacuum service to approximately 10^{-7} mm Hg absolute (3.4×10^{-12} mbar, absolute)

Maximum Allowable Pressure Drop⁽¹⁾

Maximum Allowable Shutoff: See table 1.

Maximum Flowing Pressure Drops: See table 4

Construction Materials

Valve body: ■ Cast iron, ■ carbon steel, or ■ S31600 [316 stainless steel (SST)]

Disc and Liner: See table 3.

Shaft and Taper Pins: S17400 (17-4PH SST) standard or S20910

Thrust Bearing: All cast iron or steel valves use a PTFE/bronze in a carbon steel shell; 2- through 6-inch SST valves use a PTFE-liner in a S31600 shell; 8- through 12-inch SST valves use a PTFE-liner in a fiberglass shell

Thrust Bearing Sleeves: Stainless steel

Shaft-Seal Thrust Plate: ■ Plated carbon steel (standard) or ■ S31600 SST

Thrust-Plate Cap Screws: Steel

Material Temperature Capabilities⁽¹⁾

See table 3

Flow Characteristic

Conventional Disc: Approximately equal percentage through 60 degrees of disc rotation

Fishtail® Disc: Approximately equal percentage through 90 degrees of disc rotation

Flow Direction

Conventional Disc: Bidirectional

Fishtail Disc: Forward flow –The tail of the disc opens into the downstream end of the valve

Flow Coefficients

See the section titled Coefficients in this bulletin or Catalog 12

Flow Coefficient Ratio⁽²⁾

Conventional Disc: approximately 33 to 1 for a 0 to 60 degree disc rotation

Fishtail Disc: 100 to 1 or greater for a 0 to 90 degree disc rotation

Disc Rotation

Conventional Disc:

On/Off Service: ■ 0 to 60 or ■ 0 to 90 degrees

Throttling Service: 0 to 60 degrees

Fishtail Disc: 0 to 60 or 0 to 90 degrees for on/off or throttling

Noise Levels

Refer to Catalog 12 for sound pressure level prediction

Shutoff Classification per ANSI/FCI 70-2 and IEC 60534-4

Nitrile or PTFE Liner: Class VI

Actuator/Valve Action

Field-reversible between ■ push-down-to-open (extending actuator stem opens disc) or

■ push-down-to-close (extending actuator stem closes disc)

(continued)

Specifications (continued)

Actuator Mounting

Mounting configurations are as follows: Actuator can be ■ perpendicular to (standard) or ■ parallel with pipeline with actuator to ■ right (standard) or ■ left of valve body (when viewed from valve inlet). With perpendicular mounting in horizontal pipeline, actuator can extend ■ above (standard) or ■ below pipeline. With parallel mounting, actuator can extend ■ upstream or ■ downstream of valve

Mating Flange Capabilities

All sizes compatible with weld-neck flanges; also see the Installation section for slip-on flanges

Face-to-Face Dimensions

Dimensions meet MSS SP-67 specifications for face-to-face dimensions of flangeless valves

Valve Shaft Diameters

See figure 6 and table 5

Approximate Weights

See figure 6 and table 5

Options

Three-Way Valve: For converging or diverging service. Consists of two Type 9500 valves and a single actuator mounted on a pipe tee. Actuator operates both valves through tandem linkage. Contact your Emerson Process Management sales office sizing information

Flange Adapters: Provide additional liner support for use with ■ slip-on flanges and valve bodies 6-inch and larger, ■ flexible flanges, ■ flanges having inside diameters less than or greater than standard weld-neck flanges, or for ■ dead-end service (valve installed at end of pipe run)

Valve body for mating between Class 300 flanges.

Manual Actuator: Type 1077 manual handwheel rotary actuator, or the Type 1078 declutchable manual actuator, see figure 3

1. The pressure/temperature limits in this bulletin and any other applicable standard or code limitation should not be exceeded.
2. Ratio of maximum flow coefficient to minimum usable flow coefficient.



TYPE 1077 MANUAL ACTUATOR



TYPE 1078 DECLUTCHABLE MANUAL ACTUATOR

Figure 3. Type 1077 and 1078 Manual Rotary Actuators

Table 1. Maximum Allowable Shutoff Pressure Drops⁽¹⁾

VALVE SIZE, INCHES	MAXIMUM ALLOWABLE SHUTOFF PRESSURE DROPS							
	Liquid Service				Gaseous Service			
	PTFE Liner		Nitrile Liner		PTFE Liner		Nitrile Liner	
	Cast Iron Valve Material	Steel or Stainless Steel Valve Material	Cast Iron Valve Material	Steel or Stainless Steel Valve Material	Cast Iron Valve Material	Steel or Stainless Steel Valve Material	Cast Iron Valve Material	Steel or Stainless Steel Valve Material
Bar								
2, 3, and 4	12.1	15.2	12.1	15.2	12.1	15.2	12.1	15.2
6, 8, 10, and 12	12.1	15.2	10.4	10.4	12.1	15.2	10.4	10.4
Psi								
2, 3, and 4	175	220	175	220	175	220	175	220
6, 8, 10, and 12	175	220	150	150	175	220	150	150

1. The values in this table were determined using S17400 (17-4PH SST) shaft and taper pins. If other materials are used, you must refer to Catalog 14 Pages (section D) for adjustment percentages.

Features

- **Versatile**—Conventional discs are available for bidirectional, on/off or throttling control. Valves are available with S31600 [316 stainless steel (SST)] patented Fishtail disc for on/off or throttling control (see figure 4). The discs can be obtained in a variety of alloy materials for additional corrosion resistance.

- **Economical**—Valve body and shafts are isolated from process fluid, allowing use of cast iron valve bodies for corrosive applications.

- **Adjustable Shaft Seal**—Liner is directed against a flat disc hub by a thrust bearing, creating a seal between the liner and the disc as shown in figure 5. Seals are adjusted as necessary to provide leak control.

- **Flange Gasket Not Required**—Partial O-ring (figure 5) is molded as part of the liner. It seals

against mating flanges which eliminate the need for flange gaskets.

- **Excellent Flow Control**—The conventional disc is approximately equal percentage flow characteristic through 60 degrees of its rotation. The Fishtail disc has an approximate equal percentage flow characteristic through a full 90 degrees of disc rotation.

- **Operational Economy**—The Fishtail disc reduces dynamic torque, which allows the use of a smaller actuator size for a given application.

- **Minimum Maintenance**—No lubrication is required, and no packing or flange gaskets to replace. Shaft seal is easy to adjust. Removing valve components and changing the valve action is accomplished without complete disassembly. Field-replaceable slip-in liner minimizes downtime and reduces maintenance costs.

Product Bulletin

51.4:9500
September 2006

9500 Valve

Table 2. Mating Flange Compatibility

VALVE SIZE, INCHES	CAST IRON		STEEL AND STAINLESS STEEL	
	ASME	DIN	ASME	DIN
2, 3	Class 125B	PN10	Class 150	PN16
4	Class 125B	---	Class 150	PN16
6, 8, 10	Class 125B	PN10	Class 150	PN16
12	Class 125B	---	Class 150	PN16

Table 3. Disc and Liner Materials

Disc Style	Disc Material	Liner Material	Temperature Range	
			°C	°F
Conventional	Aluminum bronze	PTFE-lined elastomer molded to aluminum backup ring	-18 to 121	0 to 250
		Nitrile molded to hard rubber backup ring	-7 to 93	20 to 200
Fishtail	S31600 stainless steel	PTFE-lined elastomer molded to aluminum backup ring	-18 to 121	0 to 250

Table 4. Maximum Allowable Flowing Pressure Drops Due to Strength Capabilities of Valve Body Components

VALVE SIZE, INCHES	MAXIMUM ALLOWABLE FLOWING PRESSURE DROPS			
	Conventional Disc		Fishtail Disc	
	At 60 Degrees Rotation	At 90 Degrees Rotation	At 60 Degrees Rotation	At 90 Degrees Rotation
Bar				
2	12.1 ⁽¹⁾	8.5	12.1 ⁽¹⁾	12.1 ⁽¹⁾
	15.2 ⁽²⁾		15.2 ⁽²⁾	15.2 ⁽²⁾
3	12.1 ⁽¹⁾	5.0	12.1 ⁽¹⁾	12.1 ⁽¹⁾
	15.2 ⁽²⁾		15.2 ⁽²⁾	15.2 ⁽²⁾
4	6.6	2.1	11.9	6.8
6	3.4	1.1	5.9	2.9
8	3.4	1.1	5.9	2.9
10	1.7	0.6	2.8	1.2
12	2.0	0.6	3.2	1.3
Psi				
2	175 ⁽¹⁾	124	175 ⁽¹⁾	175 ⁽¹⁾
	220 ⁽²⁾		220 ⁽²⁾	220 ⁽²⁾
3	175 ⁽¹⁾	73	175 ⁽¹⁾	175 ⁽¹⁾
	220 ⁽²⁾		220 ⁽²⁾	220 ⁽²⁾
4	96	31	173	99
6	50	16	85	42
8	50	16	85	42
10	25	8	41	17
12	29	9	47	19

1. For cast iron valve bodies.
2. For steel or stainless steel valve bodies.

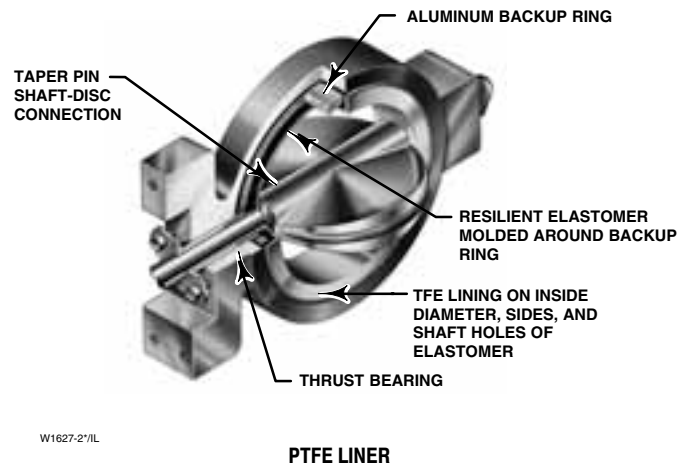
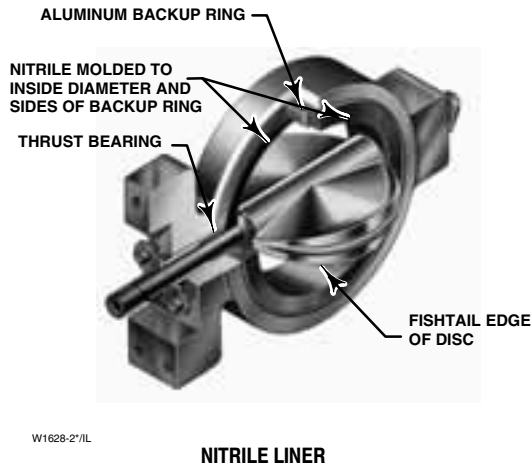

Figure 4. Sectional Views of Type 9500 Valves

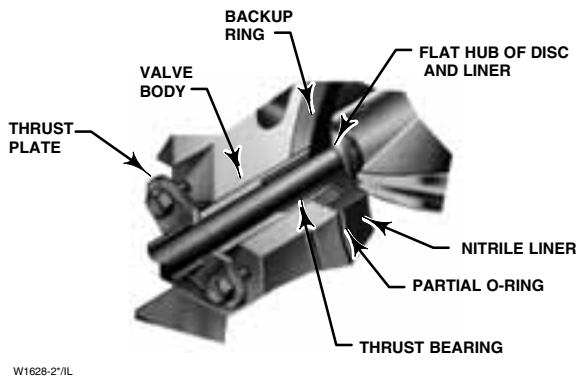

Figure 5. Adjustable Hub Seal Details

Installation

Please refer to the Type 9500 instruction manual, form 2433, for additional / complete installation and maintenance instructions.

These valves may be installed in any position. For conventional discs, flow may be in either direction. For Fishtail discs, the Fishtail edge of the discs must be located in to the downstream end of the valve (see figure 4).

The liner overlaps the valve face producing the partial O-ring shown in figure 5. It acts as the flange gasket. Improper use of additional gasketing materials may damage the valve liner.

The simplicity of the Type 9500 valve design is achieved by relying on mating pipe flanges to retain the slip-in liner in the valve body. Care must be taken during installation to assure that the pipe flanges are properly supported to avoid liner damage, flange joint leakage, and problems with valve operation. Flexible, plastic flanges; fiberglass, slip-on flanges; or weld-neck flanges with other than standard inside diameters may not provide adequate support for the liner. The use of flange adapters can overcome flange support problems during installation. Whenever a flange adapter is used, a standard flange gasket must be installed between the line flange and flange adapter. Do not use a flange gasket between the valve and flange adapter. The partial O-ring on the liner acts as the flange gasket and any additional gasket here will damage the liner.

Excessive line bolt load on flexible mating flanges can warp the liner. Also, failing to support the liner at the inside diameter can warp the liner. The use of flange adapters can overcome bolt load problems during installation.

Slip-on pipe flanges may be used with 2-, 3-, or 4-inch Type 9500 valves. Valve sizes 6-inch and larger will require flange adapters for complete liner support.

The maximum and minimum allowable inside diameter of mating flanges or adjacent pipes are given in figure 6 and table 5. Flanges or pipes with inside diameters smaller than the minimum shown may interfere with the opening of the disc. Flanges or pipes with an inside diameter larger than the maximum shown may not be in full contact with the

liner. Flange adapters are needed in either case, to provide disc clearance or to fully contact the liner.

Note

Neither Emerson, Emerson Process Management, Fisher, nor any of their affiliated entities assumes responsibility for the selection, use and maintenance of any product. Responsibility for the selection, use, and maintenance of any product remains with the purchaser and end-user.

Table 5. Dimensions

VALVE SIZE INCHES	A		B		D	E	F	Q	S (Shaft Diameter)	T	U	W	ALLOWABLE MATING FLANGE / PIPEBORE		APPROX -IMATE WEIGHT
	Class 125/150	Class 300	Class 125/150	Class 300									Min	Max	
mm															kg
2	105	111	108	114	42.00	103	187	44	12.7	117	---	3/8-16	31	63	94
3	119	129	127	137	45.00	133	211	48	15.9	146	32	3/8-16	64	92	11
4	116	151	146	159	51.00	171	211	54	15.9	146	32	3/8-16	89	117	14
6	167	186	171	191	54.00	220	214	57	19.1	146	32	3/8-16	145	171 ⁽¹⁾	20
8	198	217	203	222	61.00	276	214	64	25.4	146	32	3/8-16	196	222 ⁽¹⁾	27
10	230	249	235	254	69.00	335	214	71	25.4	146	32	3/8-16	246	273 ⁽¹⁾	32
12	268	287	273	292	78.00	405	208	81	31.8	210	51	5/8-11	297	330 ⁽¹⁾	54
Inches															Pounds
2	4.13	4.38	4.25	4.50	1.64	4.06	7.38	1.75	0.50	4.62	---	3/8-16	1.20	2.50	20
3	4.69	50.6	5.00	5.38	1.76	5.25	8.31	1.88	0.62	5.75	1.25	3/8-16	2.50	3.62	25
4	5.44	5.94	5.75	6.25	2.02	6.75	8.31	2.12	0.62	5.75	1.25	3/8-16	3.50	4.62	30
6	6.56	7.31	6.75	7.50	2.14	8.68	8.44	2.25	0.75	5.75	1.25	3/8-16	5.70	6.75 ⁽¹⁾	46
8	7.81	8.56	8.00	8.75	2.39	10.88	8.44	2.50	1.00	5.75	1.25	3/8-16	7.70	8.75 ⁽¹⁾	60
10	9.06	9.81	9.25	10.00	2.70	13.19	8.44	2.81	1.00	5.75	1.25	3/8-16	9.70	10.75 ⁽¹⁾	70
12	10.56	11.31	10.75	11.50	3.08	15.94	8.19	3.19	1.25	8.25	2.00	5/8-11	11.70	13.00 ⁽¹⁾	119

1. These size valves when installed between slip-on flanges require flange adapters for complete support.

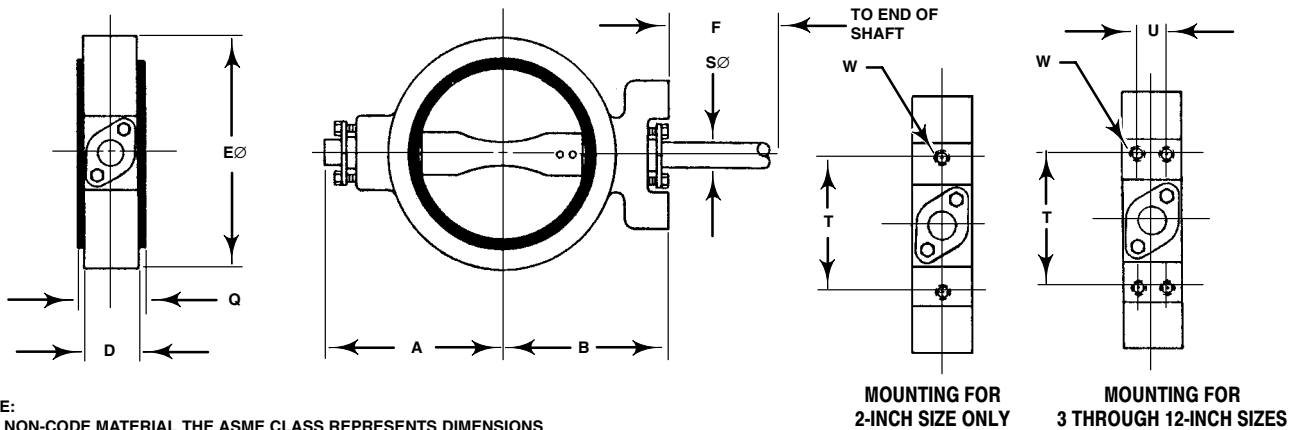

NOTE:
 FOR NON-CODE MATERIAL THE ASME CLASS REPRESENTS DIMENSIONS
 NOT PRESSURE TEMPERATURE RATING.
 DISC CHORDAL SWING DIA. AT VALVE FACE IS "M". PLEASE VERIFY
 CLEARANCE WITH PIPING.
 F68405-D
 E0747/IL

Figure 6. Dimensions (also see table 5)

Coefficients

Table 6. Type 9500, Class 125/300

Valve Size, Inches		Coefficients	Valve Rotation, Degrees								Approximately Equal Percentage Characteristic
			10	20	30	40	50	60	70	80	
2	C _v	0.2	1.8	5.7	12.7	24.0	40.1	71.4	86.7	91.2	
	K _v	0.17	1.56	4.93	11.0	20.8	34.7	61.8	75.0	78.9	
	F _L	0.78	0.80	0.82	0.84	0.80	0.74	0.67	0.59	0.55	
	X _T	0.490	0.490	0.563	0.563	0.494	0.413	0.255	0.189	0.185	
3	C _v	0.5	5.1	16.1	35.8	67.6	112	200	243	256	
	K _v	0.43	4.41	13.9	31.0	58.5	96.9	173	210	221	
	F _L	0.78	0.80	0.82	0.84	0.80	0.74	0.67	0.59	0.55	
	X _T	0.490	0.490	0.563	0.563	0.494	0.413	0.255	0.189	0.185	
4	C _v	1.0	10.3	32.6	72.5	136	227	405	492	518	
	K _v	0.87	8.91	28.2	62.7	118	196	350	426	448	
	F _L	0.78	0.80	0.82	0.84	0.80	0.74	0.67	0.59	0.55	
	X _T	0.490	0.490	0.563	0.563	0.494	0.413	0.255	0.189	0.185	
6	C _v	22.7	55.9	131	244	454	769	1120	1610	1750	
	K _v	19.6	48.4	113	211	393	665	969	1390	1510	
	F _L	0.78	0.80	0.82	0.84	0.80	0.74	0.67	0.59	0.55	
	X _T	0.391	0.394	0.426	0.436	0.449	0.375	0.270	0.139	0.128	
8	C _v	36.6	90.2	211	394	733	1240	1800	2500	2820	
	K _v	31.7	78.0	183	341	634	1070	1560	2160	2440	
	F _L	0.78	0.80	0.82	0.84	0.80	0.74	0.67	0.59	0.55	
	X _T	0.391	0.394	0.426	0.436	0.449	0.375	0.270	0.139	0.128	
10	C _v	60.2	148	347	648	1200	2040	2960	4260	4630	
	K _v	52.1	128	300	561	1040	1760	2560	3680	4000	
	F _L	0.78	0.80	0.82	0.84	0.80	0.74	0.67	0.59	0.55	
	X _T	0.391	0.394	0.426	0.436	0.449	0.375	0.270	0.139	0.128	
12	C _v	91.2	224	526	982	1820	3090	4490	6460	7020	
	K _v	78.9	194	455	849	1570	2670	3880	5590	6070	
	F _L	0.78	0.80	0.82	0.84	0.80	0.74	0.67	0.59	0.55	
	X _T	0.391	0.394	0.426	0.436	0.449	0.375	0.270	0.139	0.128	

Table 7. Type 9500, Class 125/300

Fishtail Disc		Approximately Equal Percentage Characteristic								
		Valve Rotation, Degrees								
Valve Size, Inches	Coefficients	10	20	30	40	50	60	70	80	90
2	C _v	1.81	4.78	8.37	14.3	24.6	39.5	61.7	80	91
	K _v	1.57	4.13	7.24	12.4	21.3	34.2	53.4	69.2	78.7
	F _L	0.84	0.84	0.84	0.84	0.82	0.78	0.71	0.67	0.66
	X _T	0.466	0.559	0.563	0.601	0.555	0.462	0.331	0.294	0.205
3	C _v	4.0	10.6	18.7	31.8	54.8	92	138	179	203
	K _v	3.46	9.17	16.2	27.5	47.4	79.6	119	155	176
	F _L	0.84	0.84	0.84	0.84	0.82	0.78	0.71	0.67	0.66
	X _T	0.466	0.559	0.563	0.601	0.555	0.462	0.331	0.294	0.205
4	C _v	7.75	19.4	35	61.2	102	171	275	408	490
	K _v	6.70	16.8	30.3	52.9	88.2	148	238	353	424
	F _L	0.84	0.84	0.84	0.84	0.82	0.78	0.71	0.67	0.66
	X _T	0.466	0.559	0.563	0.601	0.555	0.462	0.331	0.294	0.205
6	C _v	16.8	44.3	78.9	141	232	399	638	994	1220
	K _v	14.5	38.3	68.2	122	201	345	552	860	1060
	F _L	0.84	0.84	0.84	0.84	0.82	0.78	0.71	0.67	0.66
	X _T	0.466	0.559	0.766	0.744	0.620	0.515	0.372	0.228	0.160
8	C _v	29.9	78.8	140	252	412	710	1130	1770	2170
	K _v	25.9	68.2	121	218	356	614	977	1530	1880
	F _L	0.84	0.84	0.84	0.84	0.82	0.78	0.71	0.67	0.66
	X _T	0.466	0.559	0.766	0.744	0.620	0.515	0.372	0.228	0.160
10	C _v	46	123	222	412	672	1170	1910	3160	4010
	K _v	39.8	106	192	356	581	1010	1650	2730	3470
	F _L	0.84	0.84	0.84	0.84	0.82	0.78	0.71	0.67	0.66
	X _T	0.466	0.559	0.766	0.744	0.620	0.515	0.372	0.228	0.160
12	C _v	79	178	322	592	967	1680	2720	4470	5640
	K _v	68.3	154	279	512	836	1450	2350	3870	4880
	F _L	0.84	0.84	0.84	0.84	0.82	0.78	0.71	0.67	0.66
	X _T	0.466	0.559	0.766	0.744	0.620	0.515	0.372	0.228	0.160

Fishtail and Fisher are marks owned by Fisher Controls International LLC, a member of the Emerson Process Management business division of Emerson Electric Co. Emerson Process Management, Emerson, and the Emerson logo are trademarks and service marks of Emerson Electric Co. All other marks are the property of their respective owners.

The contents of this publication are presented for informational purposes only, and while every effort has been made to ensure their accuracy, they are not to be construed as warranties or guarantees, express or implied, regarding the products or services described herein or their use or applicability. We reserve the right to modify or improve the designs or specifications of such products at any time without notice.

Neither Emerson, Emerson Process Management, Fisher, nor any of their affiliated entities assumes responsibility for the selection, use and maintenance of any product. Responsibility for the selection, use and maintenance of any product remains with the purchaser and end-user.

Emerson Process Management

Fisher

Marshalltown, Iowa 50158 USA
 Cernay 68700 France
 Sao Paulo 05424 Brazil
 Singapore 128461

www.Fisher.com

