

Fisher® 1077 Manual Handwheel Rotary Actuator

Fisher® 1077 manual-only handwheel actuator, shown in figure 1, is for use with rotary-shaft valves such as the 9500 butterfly valve; 8532, 8560, and 8580 eccentric disc valves; V150, V200 and V300 Vee-Ball® valves; V250 valves; and CV500 and V500 valves. Figure 2 shows the gearbox of the actuator. In this actuator, torque is transmitted from the handwheel through the handwheel input shaft to a worm and drive sleeve gear (sector) with splined bore. The worm and drive sleeve gear multiply the torque and transmit it to a splined valve shaft or splined stub shaft. The size 10-KE:6 actuator additionally has a spur gear reduction drive for increased torque capability.

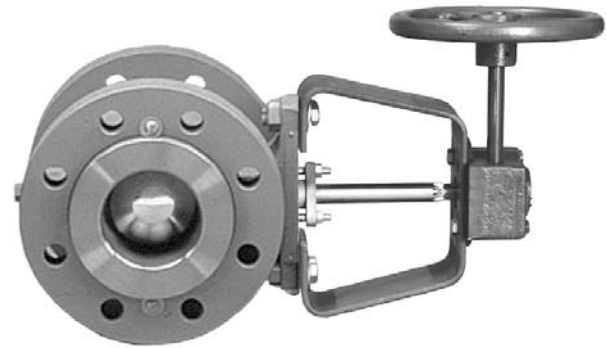

W8176-1 / IL

Figure 1. Fisher® 1077 Handwheel Actuator

Features

- Easy to Install and Maintain**—Splined valve shaft mates directly with the drive gear sleeve, reducing the number of parts required and simplifying installation and maintenance.
- Easy to Operate**—Handwheel rotation direction required to open the valve disc or ball is marked on the handwheel; the rotation indicator is marked in bold print at the open and closed positions and with bold incremental lines to indicate the valve disc or ball position.
- Consistency of Operation**—When installed according to instructions, clockwise handwheel rotation closes the valve in all applications.
- Accurate Valve Disc or Ball Positioning**—Travel stops can be adjusted and locked in place to provide accurate disc or ball positioning at closed (0-degree) and open (90-degree) positions. Travel stops for 60-degree operation may be used to establish a disc or ball

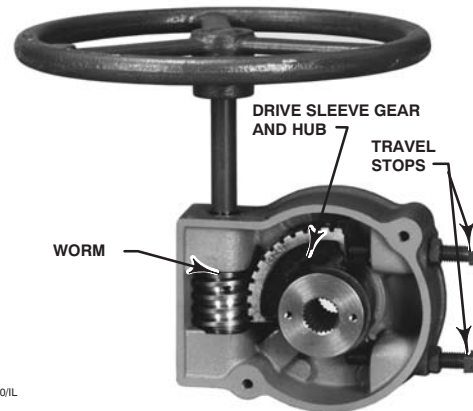

W4580/IL

Figure 2. Gearbox Subassembly

closing stop at any angle between 0 and 30 degrees and/or to establish a disc or ball opening stop at any angle between 60 and 90 degrees. This option is available on sizes 2-KE, 7-KE, 9-KE and 10-KE:6 as a set screw change. For sizes 0-KE and 6-KE, a different actuator is required when changing from 90-degree to 60-degree ball rotation.

- Choice of Handwheel or Chainwheel Operation**—Optional chainwheel is available for remote operation.



Specifications

Available Configuration

Manual-only handwheel actuator for use with splined and keyed rotary-shaft valves

Actuator Sizes

See tables 1 and 2

Acceptable Valve Shaft Diameters

See tables 1 and 2

Output Torque

See tables 1 and 2

Wheel-Rim Force

See tables 1 and 2

Handwheel Turns Required for Full Rotation

See tables 1 and 2

Handwheel Rotation

Direct Acting Construction: Clockwise handwheel rotation closes the valve (produces clockwise rotation of the valve shaft) as shown in figure 3.

Reverse Acting Construction: Clockwise handwheel rotation closes the valve (produces counterclockwise rotation of the valve shaft) as shown in figure 3.

Maximum Output Rotation

Standard: 90 degrees

Optional: 60 degrees ■ valve ball or disc closed position may be set to any angle between 0 and 30 degrees, and/or ■ valve ball or disc open position may be set to any angle between 60 and 90 degrees. (This option is available on actuator sizes 2-KE, 7-KE, 9-KE and 10-KE:6 as a set screw change. For sizes 0-KE and 6-KE a different actuator is required when changing from 90-degree to 60-degree ball rotation.)

Construction Materials

Housing: Cast iron

Housing Cover: Cast iron

Worm: Steel

Drive Sleeve Gear:

For Sizes 0-KE through 7-KE: Phosphor bronze sector with steel hub

For Sizes 9-KE and 10-KE:6: Manganese bronze sector with ductile iron hub

Worm Gear Shaft and Handwheel Shaft: Steel
Handwheel:

Through 431 mm (16-Inch) Diameter: Cast iron

Over 431 mm (16-Inch) Diameter: Fabricated steel

Mounting Yoke

For NPS 30 and 36 8510, NPS 16 V250, and any other valve with 76.2 or 88.9 mm (3 or 3-1/2 Inch) Shaft Diameter: Cast iron

For All Valve Bodies Other Than Those Listed Above: Painted steel

Mounting Positions

■ Right-hand (actuator on the right side of the valve when viewed from the valve inlet) or ■ Left-hand (actuator on the left side of the valve when viewed from the valve inlet). Position 1 as shown in figure 4 is standard; however, the actuator may be mounted in any of the positions shown in figure 4. Refer to figure 3 to determine the correct actuator construction.

Approximate Weight

ACTUATOR	METRIC UNITS		U.S. UNITS	
	Handwheel Diameter, mm	Weight of Actuator Assembly, kg	Handwheel Diameter, Inches	Weight of Actuator Assembly, Pounds
0-KE	152	3.7	6	8
	203	4.7	8	10
2-KE	203	10.3	8	22
	305	11.3	12	24
6-KE	610	20.2	24	43
7-KE	762	28.2	30	60
9-KE	914	40.9	36	87
10-KE:6	432	62.6	16	133
	610	62.6	24	133

Options

Chainwheel and Chain: Chainwheel diameters are nominally equal to handwheel diameters

Accessories

Position and Limit Switches: ■ One position switch, or ■ One or two limit switches, can be mounted

Product Bulletin

61.8:1077
April 2009

1077 Handwheel Actuator

Table 1. Actuator Size Selection (Metric Units)

ACTUATOR SIZE	ACCEPTABLE VALVE SHAFT DIAMETER	MAXIMUM ALLOWABLE TORQUE ⁽¹⁾	HAND-WHEEL DIAMETER	WHEEL-RIM FORCE		HANDWHEEL TURNS REQUIRED FOR FULL VALVE DISC OR BALL ROTATION	
				To Produce Maximum Allowable Torque	To Produce Torque Lower Than Maximum Allowable Shaft Torque	60-Degree Rotation	90-Degree Rotation
	mm	N•m	mm	N	N		
0-KE	12.7	58	152	129	Torque Req'd (N•m) ÷ 0.4572	4	6
	15.9	138	152	307			
	19.1 22.2 and 25.4	240 271 ⁽²⁾	203 ⁽⁴⁾ 203	396 445 ⁽³⁾	Torque Req'd (N•m) ÷ 0.6096	4	6
2-KE	22.2 and 25.4	468	203	485	Torque Req'd (N•m) ÷ 0.9652	6-1/2	9-1/2
	31.8	678 ⁽²⁾	305	467 ⁽³⁾	Torque Req'd (N•m) ÷ 1.4478	6-1/2	9-1/2
	38.1	678 ⁽²⁾	305	467 ⁽³⁾			
6-KE	31.8	1110	610	365	Torque Req'd (N•m) ÷ 3.0480	6-1/2	10
	38.1	1360 ⁽²⁾	610	445			
	44.5	1360 ⁽²⁾	610	445 ⁽³⁾			
	50.8	1360 ⁽²⁾	610	445 ⁽³⁾			
7-KE	44.5	2260 ⁽²⁾	762	440 ⁽³⁾	Torque Req'd (N•m) ÷ 5.1435	9	13-1/2
	50.8	2260 ⁽²⁾	762	440 ⁽³⁾			
9-KE	44.5	2260	762	436	Torque Req'd (N•m) ÷ 6.096	10-1/2	16
	50.8	2260	762	436			
	63.5	3390 ⁽²⁾	914	463 ⁽³⁾	Torque Req'd (N•m) ÷ 7.3152	10-1/2	16
10-KE:6	63.5	6305	431	431	Torque Req'd (N•m) ÷ 15.476	48	72
	76.2	6780 ⁽²⁾	610	310 ⁽³⁾	Torque Req'd (N•m) ÷ 21.848	48	72
	88.9	6780 ⁽²⁾	610	310 ⁽³⁾	Torque Req'd (N•m) ÷ 21.848	48	72

1. Values shown are the maximum allowable torque of a splined valve shaft except where indicated. Without regard to the shaft, maximum allowable torque output is 271 N•m for the size 0-KE actuator, 678 N•m for the size 2-KE actuator, 1360 N•m for the size 6-KE actuator, 2260 N•m for the size 7-KE actuator, 3390 N•m for the size 9-KE actuator, and 6780 N•m for the size 10-KE:6 actuator.
2. Limited to this value by the maximum allowable output torque of the actuator.
3. Wheel-rim force required to produce maximum actuator output torque.
4. Handwheel is 152 mm (6-inch) diameter for keyed-shaft constructions.

1077 Handwheel Actuator

Table 2. Actuator Size Selection (U.S Units)

ACTUATOR SIZE	ACCEPTABLE VALVE SHAFT DIAMETER	MAXIMUM ALLOWABLE TORQUE ⁽¹⁾	HAND-WHEEL DIAMETER	WHEEL-RIM FORCE		HANDWHEEL TURNS REQUIRED FOR FULL VALVE DISC OR BALL ROTATION	
				To Produce Maximum Allowable Torque	To Produce Torque Lower Than Maximum Allowable Shaft Torque	60-Degree Rotation	90-Degree Rotation
				Pounds	Pounds		
0-KE	1/2	515	6	29	Torque Req'd	4	6
	5/8	1225	6	69	(In.-Lb.) ÷ 18.00		
	3/4 7/8 and 1	2120 2400 ⁽²⁾	8 ⁽⁴⁾ 8	89 100 ⁽³⁾	Torque Req'd (In.-Lb.) ÷ 24.00	4	6
2-KE	7/8 and 1	4140	8	109	Torque Req'd (In.-Lb.) ÷ 38.00	6-1/2	9-1/2
	1-1/4 1-1/2	6000 ⁽²⁾ 6000 ⁽²⁾	12 12	105 ⁽³⁾ 105 ⁽³⁾	Torque Req'd (In.-Lb.) ÷ 57.00	6-1/2	9-1/2
6-KE	1-1/4	9820	24	82	Torque Req'd (In.-Lb.) ÷ 120.00	6-1/2	10
	1-1/2	12,000	24	100			
	1-3/4	12,000 ⁽²⁾	24	100 ⁽³⁾			
	2	12,000 ⁽²⁾	24	100 ⁽³⁾			
7-KE	1-3/4	20,000 ⁽²⁾	30	99 ⁽³⁾	Torque Req'd (In.-Lb.) ÷ 202.50	9	13-1/2
	2	20,000 ⁽²⁾	30	99 ⁽³⁾			
9-KE	1-3/4	23,524	30	98	Torque Req'd (In.-Lb.) ÷ 240.00	10-1/2	16
	2	23,524	30	98			
10-KE:6	2-1/2	30,000 ⁽²⁾	36	104 ⁽³⁾	Torque Req'd (In.-Lb.) ÷ 288.00	10-1/2	16
	2-1/2	55,762	16	97	Torque Req'd (In.-Lb.) ÷ 612.00	48	72
	3	60,000 ⁽²⁾	24	69 ⁽³⁾	Torque Req'd (In.-Lb.) ÷ 864	48	72
	3-1/2	60,000 ⁽²⁾	24	69 ⁽³⁾	Torque Req'd (In.-Lb.) ÷ 864	48	72

1. Values shown are the maximum allowable torque of a splined valve shaft except where indicated. Without regard to the shaft, maximum allowable torque output is 2400 inch-pounds for the size 0-KE actuator, 6000 inch-pounds for the size 2-KE actuator, 12,000 inch-pounds for the size 6-KE actuator, 20,000 inch-pounds for the size 7-KE actuator, 30,000 inch-pounds for the size 9-KE actuator, and 60,000 inch-pounds for the size 10-KE:6 actuator.
2. Limited to this value by the maximum allowable output torque of the actuator.
3. Wheel-rim force required to produce maximum actuator output torque.
4. Handwheel is 152 mm (6-inch) diameter for keyed-shaft constructions.

Product Bulletin

61.8:1077
April 2009

1077 Handwheel Actuator

Table 3. Direct and Reverse Acting Actuator Constructions

MOUNTING	VALVE SERIES OR DESIGN				VALVE SERIES OR DESIGN		
	Ball/Plug Rotation To Close	V250	V150, V200 and V300	CV500 V500	Disc/Ball Rotation To Close	V250	8532, 8560 8580, and 9500
Right-Hand	CCW CW	REVERSE	REVERSE	REVERSE	CW CW	NA NA	DIRECT
Left-Hand	CCW CCW	NA NA	REVERSE	REVERSE	CW CW	DIRECT	DIRECT
Left-Hand (Optional) ⁽¹⁾	CW CW	NA NA	DIRECT	NA NA	NA NA	NA NA	NA NA

1. A left hand ball will be required for the NPS 3 through 12 Series B and the NPS 14 to 20, with or without attenuator.

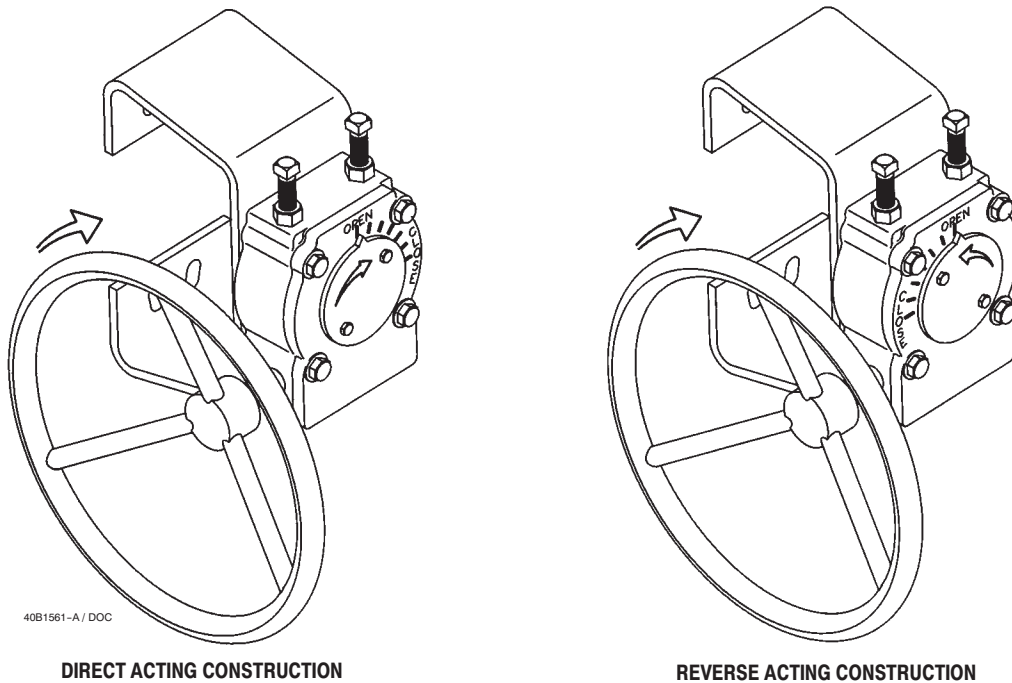
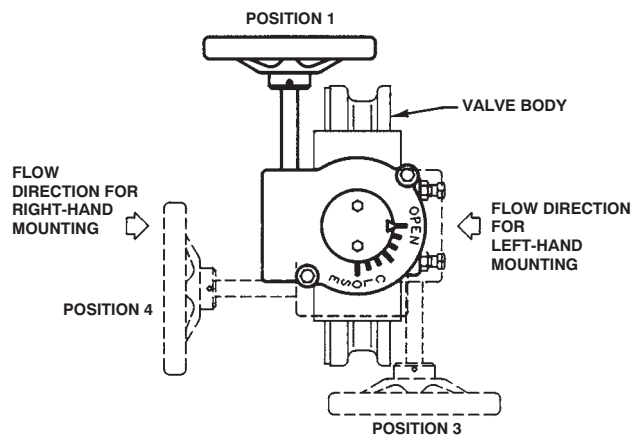

Figure 3. Direct and Reverse Acting Actuator Constructions (also see table 3)

Installation

The valve body and actuator assembly may be installed in any of the positions shown in figure 4. The actuator will be factory mounted on the valve body in the position specified.

Dimensions are shown in figure 5. Make clearance considerations before mounting the actuator to determine the most suitable mounting position.



DIRECT ACTING ACTUATOR CONSTRUCTION

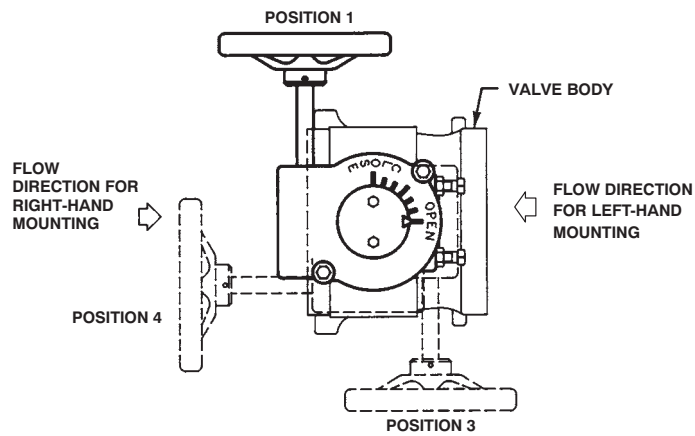

REVERSE ACTING ACTUATOR CONSTRUCTION

30B0668-A
B2002-3 / IL

Figure 4. Available Mounting Positions

Product Bulletin

61.8:1077
April 2009

1077 Handwheel Actuator

Table 4. Envelope Dimensions

ACTUATOR SIZE	HANDWHEEL DIAMETER JØ	VALVE SHAFT DIAMETER	F	H	L	M	N	V	Z
mm									
0-KE	152	12.7, 15.9	70	164	45	52	111	186	222
	203	19.1 ⁽²⁾ , 22.2, 25.4		170					
2-KE	203	22.2, 25.4	124	221	79	79	111	187	230
	305	31.8, 38.1		238			165	200	243
6-KE	610	31.8, 38.1	145	356	83	84	165	213	260
		44.5, 50.8					191	321	368
7-KE	762	44.5, 50.8	152	381	105	103	191	324	384
9-KE	762	44.5, 50.8	178	406	119	117	191	346	432
	914	63.5					241		
		63.5 ⁽¹⁾					305		
10-KE:6	406	63.5	178	419	127	117	241	346	432
		63.5 ⁽¹⁾					305		
	610	76.2, 88.9							
0-KE0	6.00	1/2, 5/8	2.75	6.44	1.75	2.06	4.38	7.31	8.75
	8.00	3/4 ⁽²⁾ , 7/8, 1		6.69					
2-KE	8.00	7/8, 1	4.88	8.69	3.12	3.12	4.38	7.38	9.06
	12.00	1-1/4, 1-1/2		9.38			6.50	7.88	9.56
6-KE	24.00	1-1/4, 1-1/2	5.69	14.00	3.25	3.31	6.50	8.38	10.25
		1-3/4, 2					7.50	12.62	14.50
7-KE	30.00	1-3/4, 2	6.00	15.00	4.12	4.06	7.50	12.75	15.12
9-KE	30.00	1-3/4, 2	7.00	16.00	4.69	4.62	7.50	13.62	17.00
	36.00	2-1/2					9.50		
		2-1/2 ⁽¹⁾					12.00		
10-KE:6	16.00	2-1/2	7.00	16.50	5.00	4.62	9.50	13.62	17.00
		2-1/2 ⁽¹⁾					12.00		
	24.00	3, 3-1/2							

1. Used with NPS 30, 36 8510 and NPS 16 V250.
2. The 19.1 mm (3/4-inch) keyed shaft construction uses a 152 mm (6-inch) handwheel.

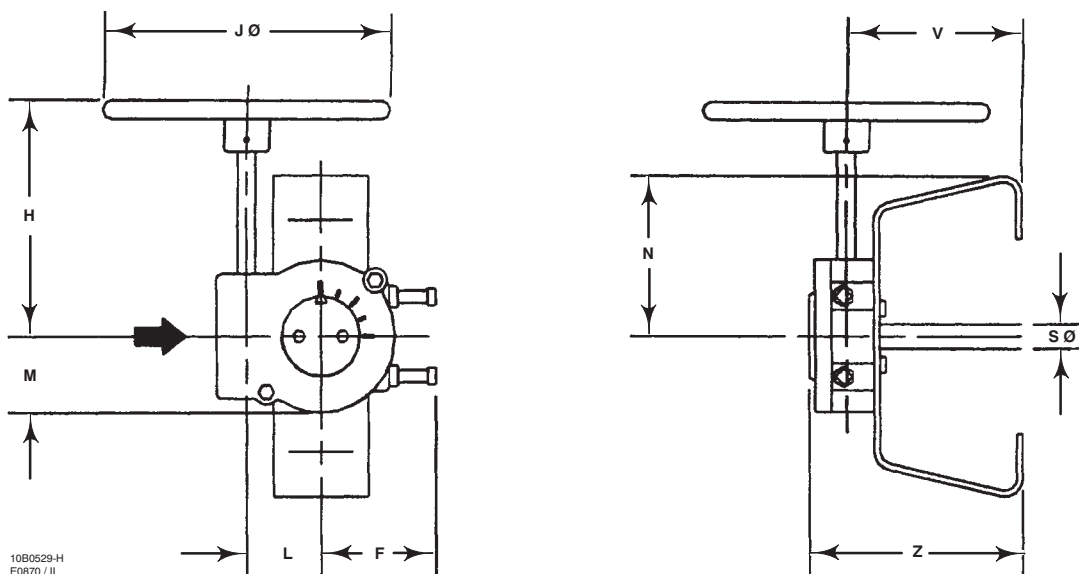

Figure 5. Envelope Dimensions (also see table 4)

Ordering Information

When ordering, specify:

Application

1. Valve body type or design, size, and shaft diameter.
2. Valve disc or ball rotation (e.g., 0 to 60 or 0 to 90 degrees). For adjustability between 0 and 30 degrees for the closed stop position, or for adjustability between 60 and 90 degrees for the open stop position, the 60-degree travel stop is used. This option is available on actuator sizes 2-KE, 7-KE, 9-KE and 10-KE:6 as a set screw change. For sizes 0-KE and 6-KE a different actuator is required when changing from 90-degree to 60-degree ball rotation.
3. Right- or left-hand mounting and desired mounting position from figure 4. If the control valve assembly is to be used for bidirectional flow, assume that the flow direction arrows in figure 4 point to the seal retainer or flow ring end of the valve body.

Handwheel Actuator

Refer to the Specifications section. Review the description for each specification and in the referenced tables and figures. Indicate a choice whenever there is a selection to be made.

Note

When specifying a mounting position, make certain that the handwheel diameter specified will not interfere with the valve body, pipe flanges, or line bolting connected to the system.

Options and Accessories

If ordering a chainwheel, specify the distance between the valve shaft centerline and the elevation from which the chain is to be operated.

If ordering limit switches, specify the number of switches desired (one or two). For one limit switch, specify whether switching is to occur at the open or closed valve position.

Valve Body and Accessories

Refer to the separate valve body and accessory information bulletins for ordering information.

Note

Neither Emerson, Emerson Process Management, nor any of their affiliated entities assumes responsibility for the selection, use, or maintenance of any product. Responsibility for the selection, use, and maintenance of any product remains with the purchaser and end-user.

Fisher and Vee-Ball are marks owned by one of the companies in the Emerson Process Management business division of Emerson Electric Co. Emerson Process Management, Emerson, and the Emerson logo are trademarks and service marks of Emerson Electric Co. All other marks are the property of their respective owners.

The contents of this publication are presented for informational purposes only, and while every effort has been made to ensure their accuracy, they are not to be construed as warranties or guarantees, express or implied, regarding the products or services described herein or their use or applicability. All sales are governed by our terms and conditions, which are available upon request. We reserve the right to modify or improve the designs or specifications of such products at any time without notice. Neither Emerson, Emerson Process Management, nor any of their affiliated entities assumes responsibility for the selection, use or maintenance of any product. Responsibility for proper selection, use, and maintenance of any product remains solely with the purchaser and end-user.

Emerson Process Management

Marshalltown, Iowa 50158 USA

Sorocaba, 18087 Brazil

Chatham, Kent ME4 4QZ UK

Dubai, United Arab Emirates

Singapore 128461 Singapore

www.Fisher.com

